



CMS32L051 Datasheet

ARM® Cortex®-M0+ based, ultra low power consumption 32-bit microcontroller

Built-in 64K byte Flash, rich analog function, timer and various communication interfaces

V1.9.5

Please note the following CMS IP policy

* China Micro Semicon (Shenzhen) Co., Ltd. (hereinafter referred to as the Company) has applied for a patent and enjoys absolute legal rights and interests. The patent rights related to the Company's MCUs or other products have not been authorized to be licensed, and any company, organization or individual who infringes the Company's patent rights through improper means will take all possible legal actions to curb the infringer's improper infringement and recover the losses suffered by the Company as a result of the infringement or the illegal benefits obtained by the infringer.

* The name and logo of China Micro Semicon (Shenzhen) Co., Ltd. are registered trademarks of the Company.

* The Company reserves the right to further explain the reliability, functionality and design improvements of the products in the data sheet. However, the Company is not responsible for the use of the Specification Contents. The applications mentioned herein are for illustrative purposes only and the Company does not warrant and does not represent that these applications can be applied without further modification, nor does it recommend that its products be used in places that may cause harm to persons due to malfunction or other reasons. The Company's products are not licensed for lifesaving, life-sustaining devices or systems as critical devices. The Company reserves the right to modify the product without prior notice, please refer to the official website www.mcu.com.cn for the latest information.

Features

- **Ultra-low power operating environment:**
 - Power supply voltage range: 1.8V to 5.5V
 - Temperature range: -40°C to 105°C
 - Low power consumption mode: sleep mode, deep sleep mode
 - Operating power consumption: 70uA/MHz@64MHz
 - Power consumption in deep sleep mode:80uA
- **Core:**
 - ARM®32-bitCortex®-M0+ CPU
 - Working frequency: 32KHz~64MHz
- **Memory:**
 - 64KB Flash memory, with program and data storage shared
 - 1.5KB dedicated data Flash memory
 - 8KB SRAM memory with parity check
- **Power and reset management:**
 - Built-in power-on reset (POR) circuit
 - Built-in voltage detection (LVD) circuit (threshold voltage can be set)
- **Clock management:**
 - Built-in high-speed vibrator, accuracy ($\pm 1\%$). Can provide 2MHz~64MHz system clock and peripheral module operation clock
 - Built-in 15KHz low-speed oscillator
 - Support 1MHz~20MHz external crystal oscillator
 - Support 32.768KHz external crystal oscillator, can be used to calibrate the internal high-speed vibrator
- **Multiplier module:**
 - Support single cycle 32bit multiplication operation
- **Enhanced DMA controller:**
 - Interrupt trigger start.
 - Transmission mode is selectable (normal transmission mode, repeated transmission mode, block transmission mode and chain transmission mode)
 - The transmission source/destination area is optional for the full address space range
- **Analog peripheral:**
 - 12-bit precision ADC converter, conversion rate 500Ksps, 35 external analog channels, internal optional PGA0 output as conversion channel, with temperature sensor, support single-channel conversion mode and multi-channel scan conversion mode Conversion range: 0 to positive reference voltage
- **Input/output port:**
 - Number of I/O port: 16~45
 - Can switch between N-channel open drain and internal pull-up and pull-down
 - Built-in button interrupt detection function
 - Built-in clock output/buzzer output control circuit
- **Serial two-wire debugger (SWD)**
- **Abundant timer:**
 - 16-bit timer: 8 channels
 - 15-bit interval timer: 1
 - Real-time clock (RTC): 1 (with perpetual calendar, alarm clock function, and supports a wide range of clock correction)
 - Watchdog timer (WWDT): 1
 - SysTick timer
- **Abundant and flexible interface:**
 - 3-channel serial communication unit: each channel can be freely configured as a 1-channel standard UART, 2-channel SPI or 2-channel simple I²C
 - Standard SPI: 1 channel (support 8bit and16bit)
 - Standard I²C: 1 channel
 - IrDA: 1 channel
- **security function:**
 - Comply with relevant standards of IEC/UL 60730
 - Abnormal storage space access error
 - Support RAM parity check
 - Support hardware CRC check
 - Support important SFR protection to prevent misoperation
 - 128-bit unique ID number

- **Linkage controller:**
 - The event signals can be linked together to realize the linkage of peripheral functions.
 - 15 types of event input, 4 types of event trigger.
- Flash secondary protection in debug mode (Level1: only the entire Flash area can be erased, not read or write; Level2: the emulator connection is invalid, and Flash operation is not allowed)
- **Encapsulation:**
 - Support multiple encapsulation of 20Pin, 24Pin, 32Pin, 40Pin, 48 Pin

1 Overview

1.1 Introduction

Ultra-low power consumption CMS32L051 uses high-performance 32-bit RISC core of ARM®Cortex®-M0+, can work at 64 MHz, and adopts high-speed embedded flash memory (SRAM max. 8KB, program/data flash memory max. 64KB) This product integrates multiple standard interfaces of I²C, SPI, UART and LIN. Integrated 12bit A/D converter, temperature sensor. Among them, the 12bit A/D converter can collect external sensor signals, reducing system design costs. The temperature sensor integrated in the chip can realize real-time monitoring of the external ambient temperature. Integrated 8-channel 16bit timer module, and equipped with EPWM control circuit, combined with the timer can realize the control of one DC motor or two stepper motors.

CMS32L051 also has excellent low-power performance, supports two low-power modes of sleep and deep sleep, and is designed to be flexible. Its operating power consumption is 70uA/MHz@64MHz, which is suitable for battery-powered low-power devices. At the same time, due to the integrated event linkage controller, direct connection between hardware modules can be realized without the intervention of the CPU, which is faster than using interrupt response, while reducing the frequency of CPU activity and prolonging the battery life.

These features make the CMS32L051 microcontroller series can be widely used in consumer civil products, such as household appliances, mobile devices, etc.

1.2 Product Model List

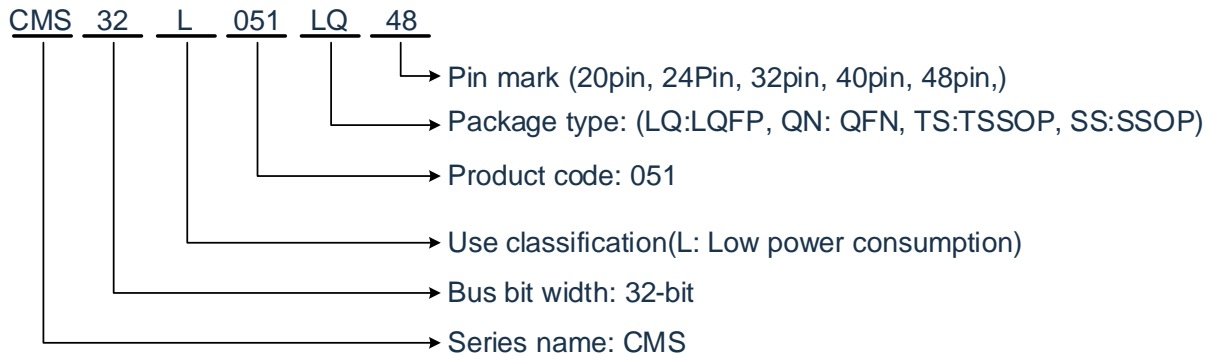

List of products of CMS32L051:

Number of Pin	Encapsulation	Product model
20pin	20-pin plastic package TSSOP (6.5X4.4mm, 0.65mm pitch)	CMS32L051TS20
20pin	20-pin plastic package QFN (3X3mm, 0.4mm pitch)	CMS32L051QN20
24pin	24-pin plastic package SSOP (8.65X3.9mm, 0.635mm pitch)	CMS32L051SS24
24pin	24-pin plastic package QFN (4X4mm, 0.5mm pitch)	CMS32L051QN24
32pin	32-pin plastic package QFN (5X5mm, 0.5mm pitch)	CMS32L051QN32
32pin	32-pin plastic package LQFP (7X7mm, 0.8mm pitch)	CMS32L051LQ32
40pin	40-pin plastic package QFN (5X5mm, 0.4mm pitch)	CMS32L051QN40
48pin	48-pin plastic package LQFP (7X7mm, 0.5mm pitch)	CMS32L051LQ48

FLASH, SRAM capacity:

Flash memory	Special data Flash memory	SRAM	CMS32L051				
			20pin	24pin	32pin	40pin	48pin
64KB	1.5KB	8KB	CMS32L051TS20	CMS32L051SS24	CMS32L051QN32	CMS32L051QN40	CMS32L051LQ48
			CMS32L051QN20	CMS32L051QN24	CMS32L051LQ32		

1.3 Pin Connection Diagram (Top View)

1.3.1 CMS32L051TS20 Pin Diagram

- 20-pin plastic package TSSOP (6.5x4.4mm, 0.65mm pitch)

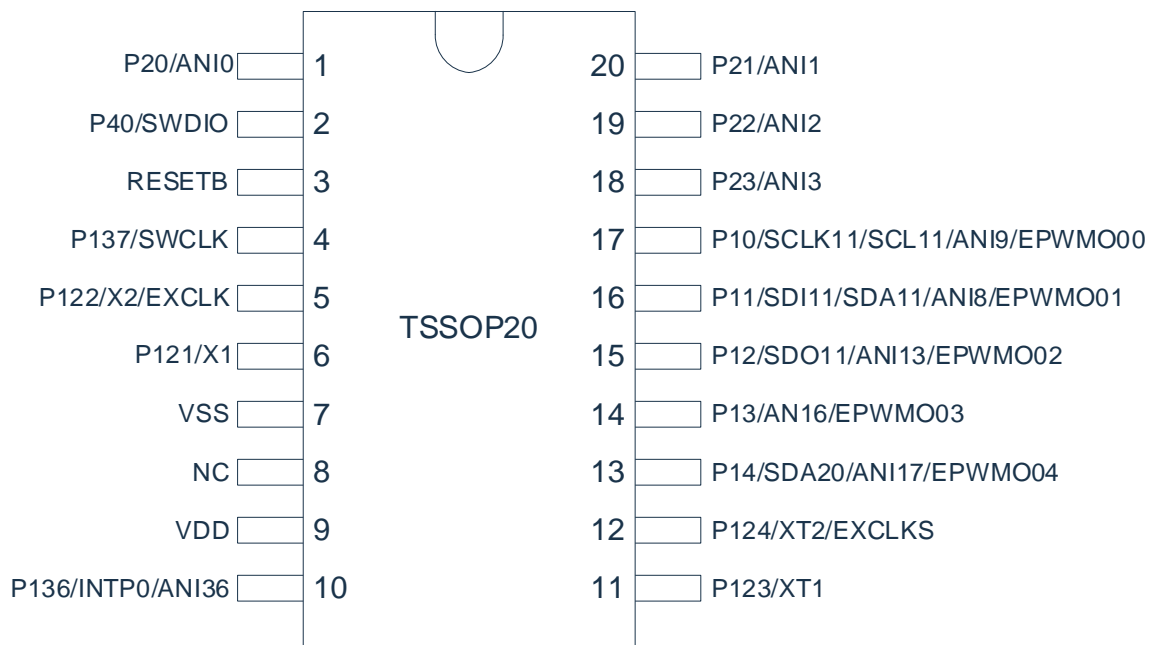

Remark: The unmarked digital function support pins in the figure are configurable, see section 4.1 for details.

1.3.2 CMS32L051QN20 Pin Diagram

- 20-pin plastic package QFN (3x3mm, 0.4mm pitch)

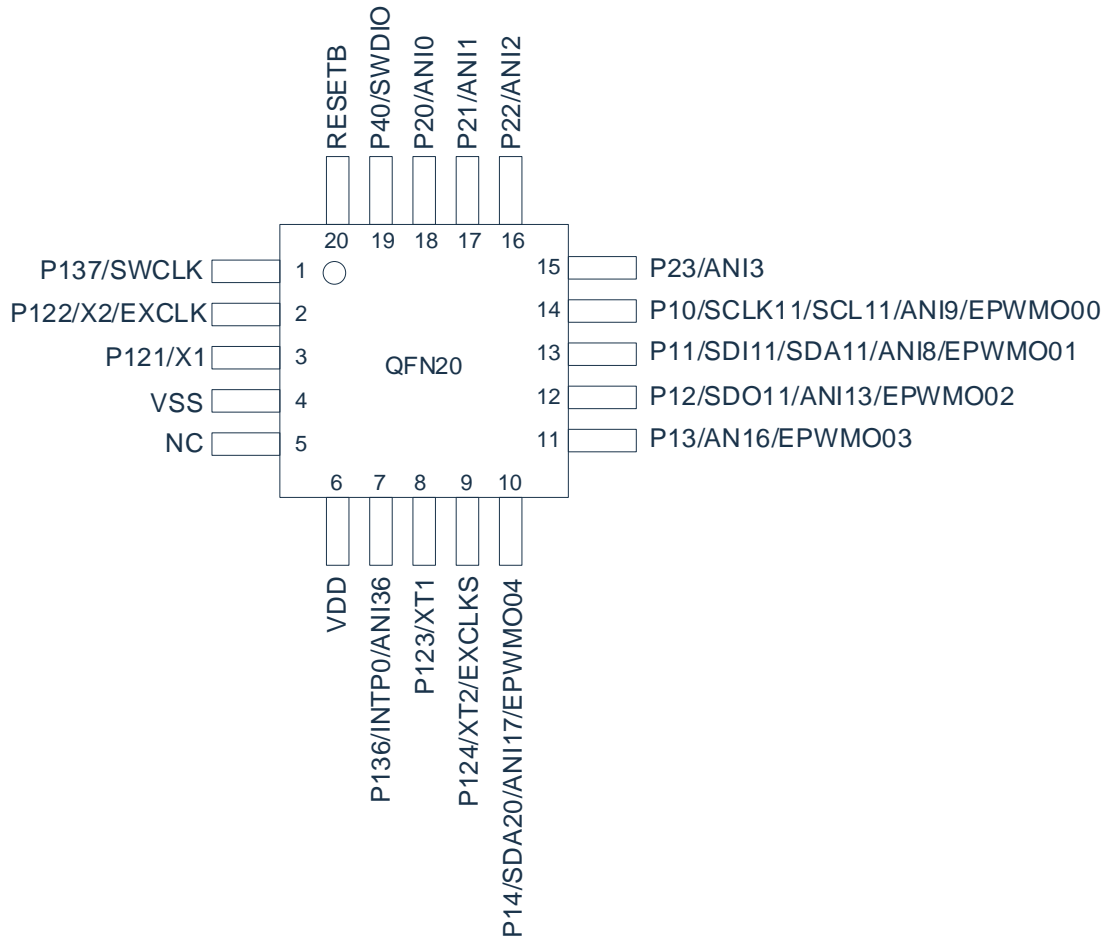

Remark: The unmarked digital function support pins in the figure are configurable, see section 4.1 for details

1.3.3 CMS32L051SS24 Pin Diagram

- 24-pin plastic package SSOP (8.65x3.9mm, 0.635mm pitch)

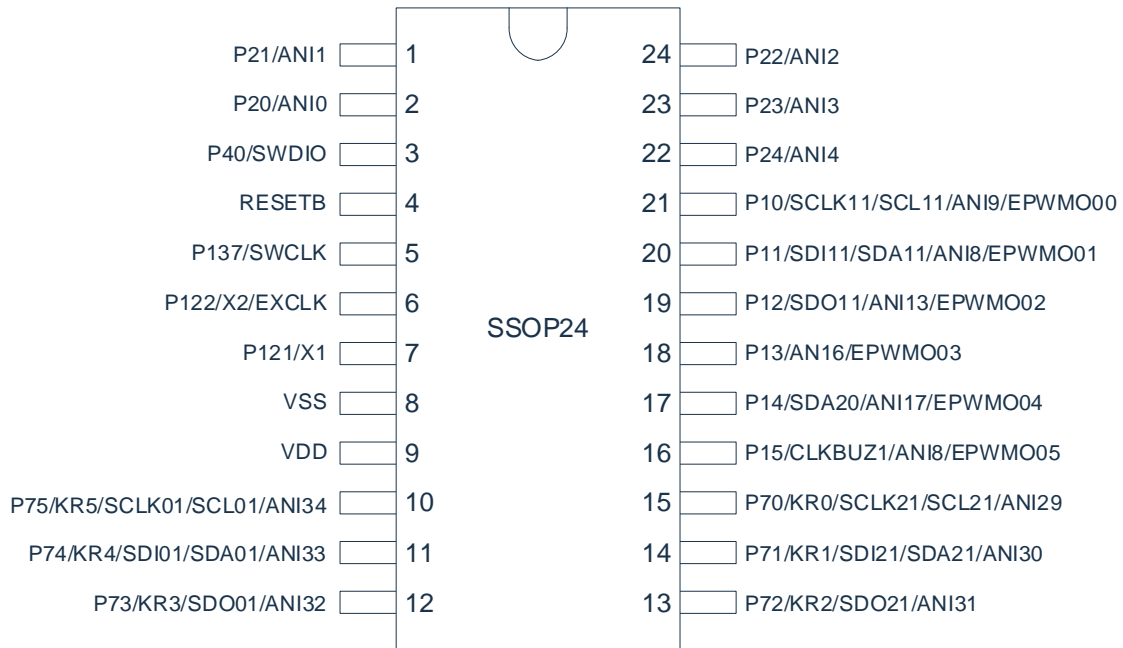

Remark: The unmarked digital function support pins in the figure are configurable, see section 4.1 for details

1.3.4 CMS32L051QN24 Pin Diagram

- 24-pin plastic package QFN (4x4mm, 0.5mm pitch)

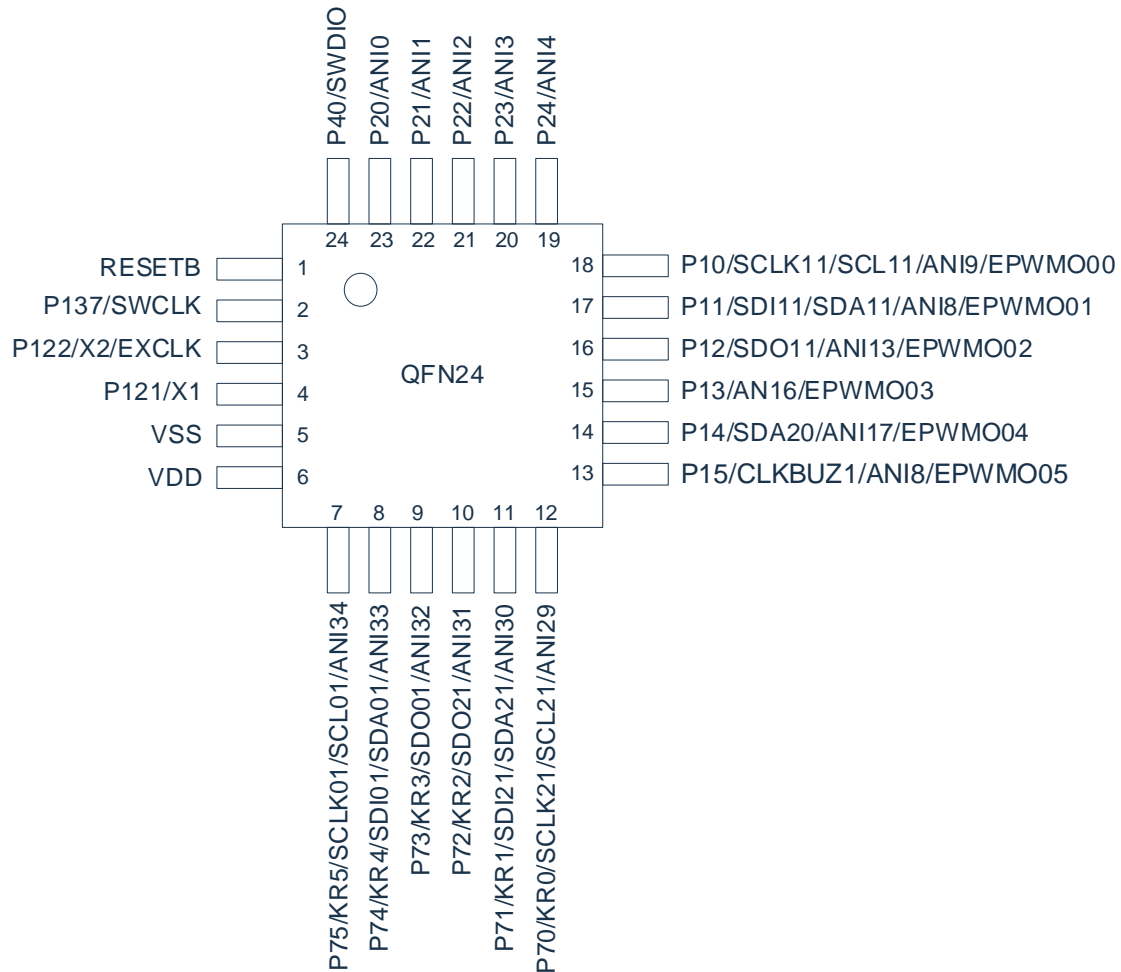

Remark: The unmarked digital function support pins in the figure are configurable, see section 4.1 for details.

1.3.5 CMS32L051LQ32 Pin Diagram

- 32-pin plastic package LQFP (7x7mm, 0.8mm pitch)

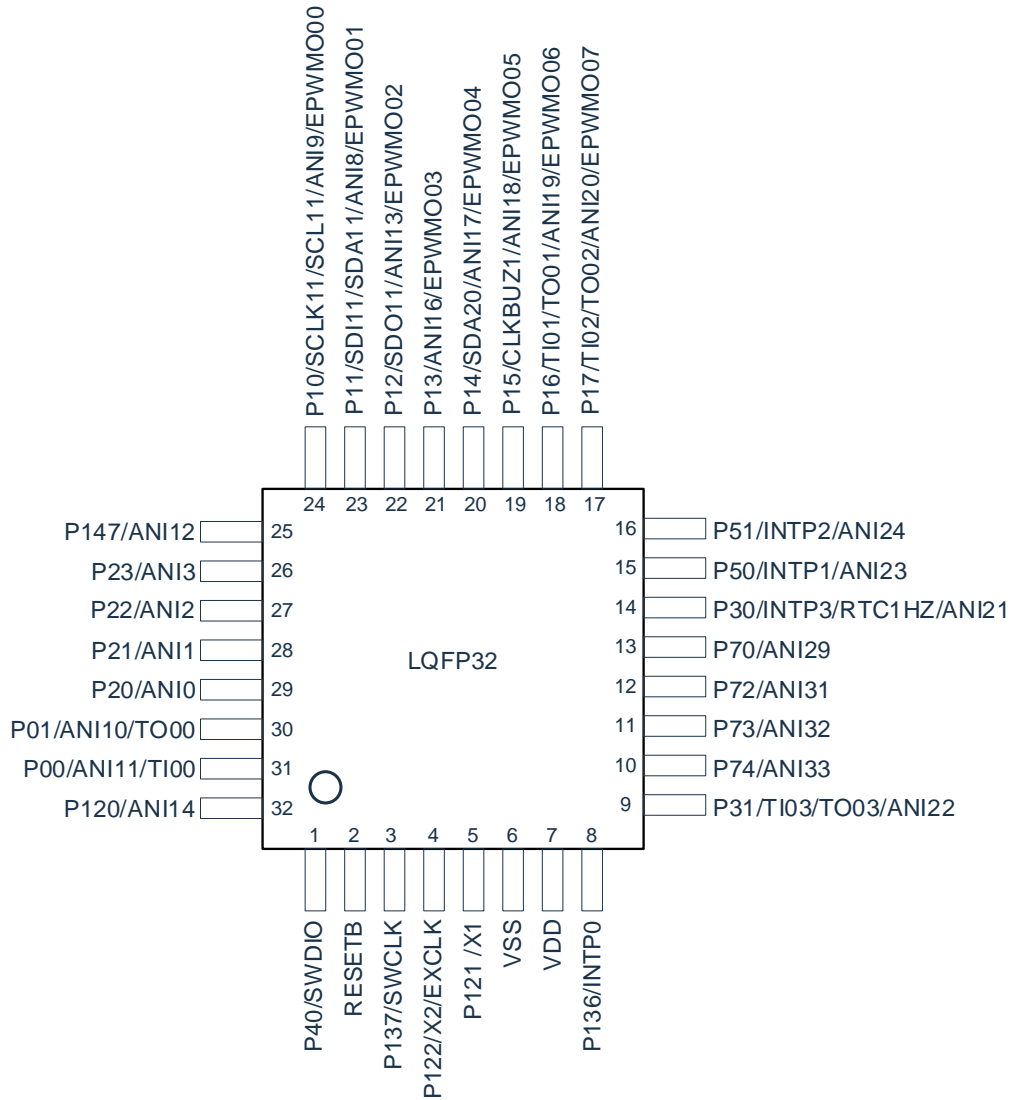

Remark: The unmarked digital function support pins in the figure are configurable, see section 4.1 for details.

1.3.6 CMS32L051QN32 Pin Diagram

- 32-pin plastic package QFN (5x5mm, 0.5mm pitch)

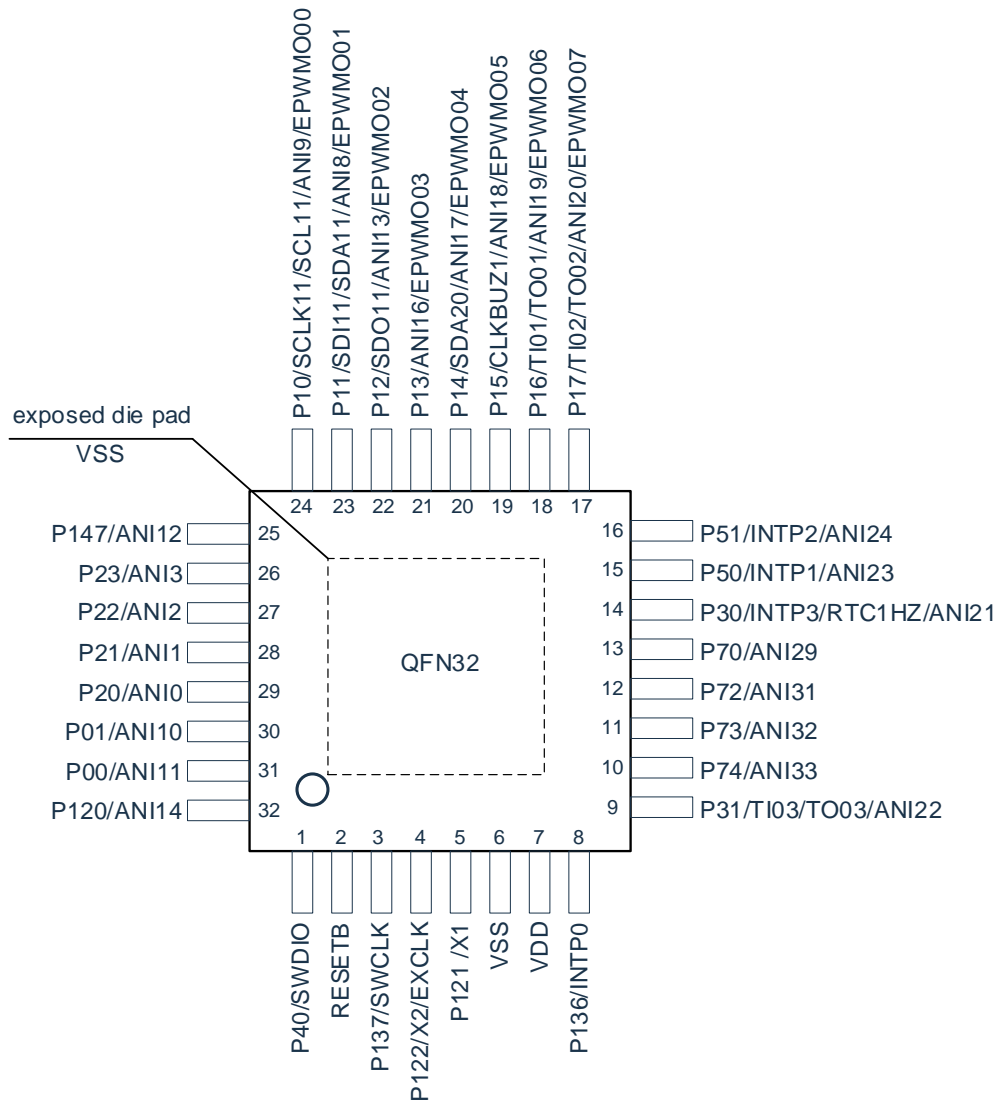

Remark: The unmarked digital function support pins in the figure are configurable, see section 4.1 for details.

1.3.7 CMS32L051QN40 Pin Diagram

- 40-pin plastic package QFN (5x5mm, 0.4mm pitch)

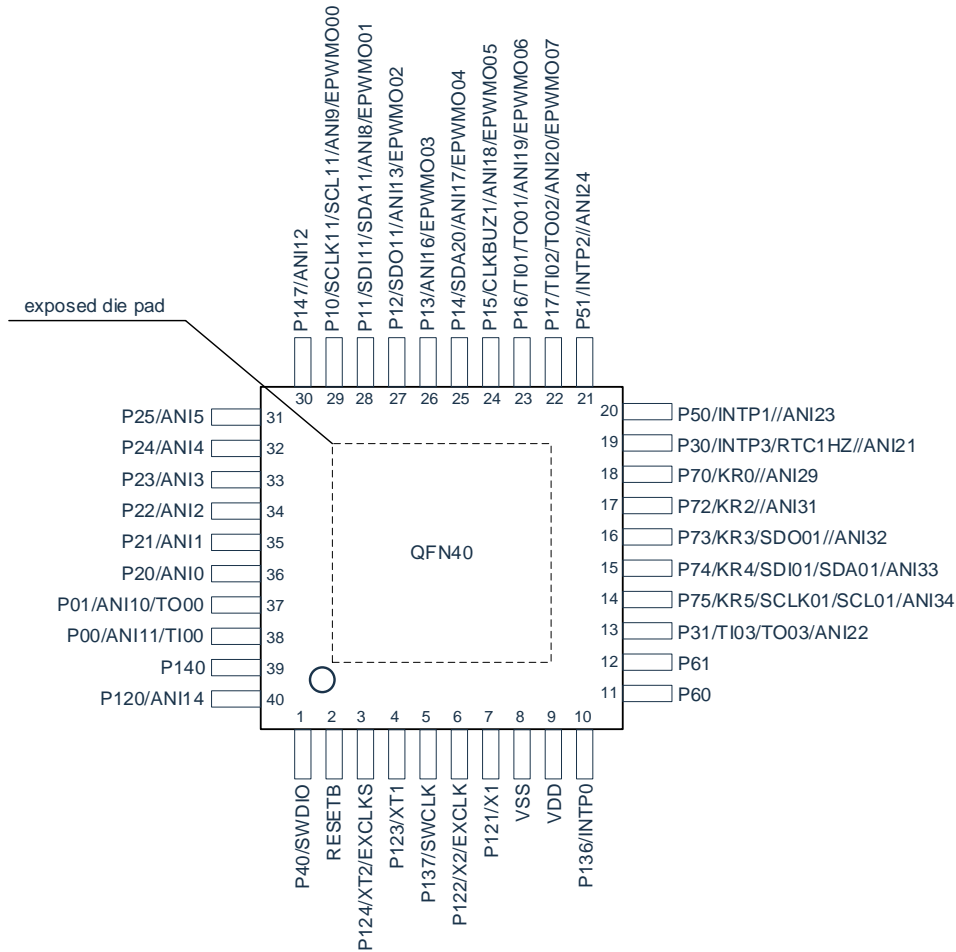

Remark: The unmarked digital function support pins in the figure are configurable, see section 4.1 for details.

1.3.8 CMS32L051LQ48 Pin Diagram

- 48-pin plastic package LQFP (7x7mm, 0.5mm pitch)

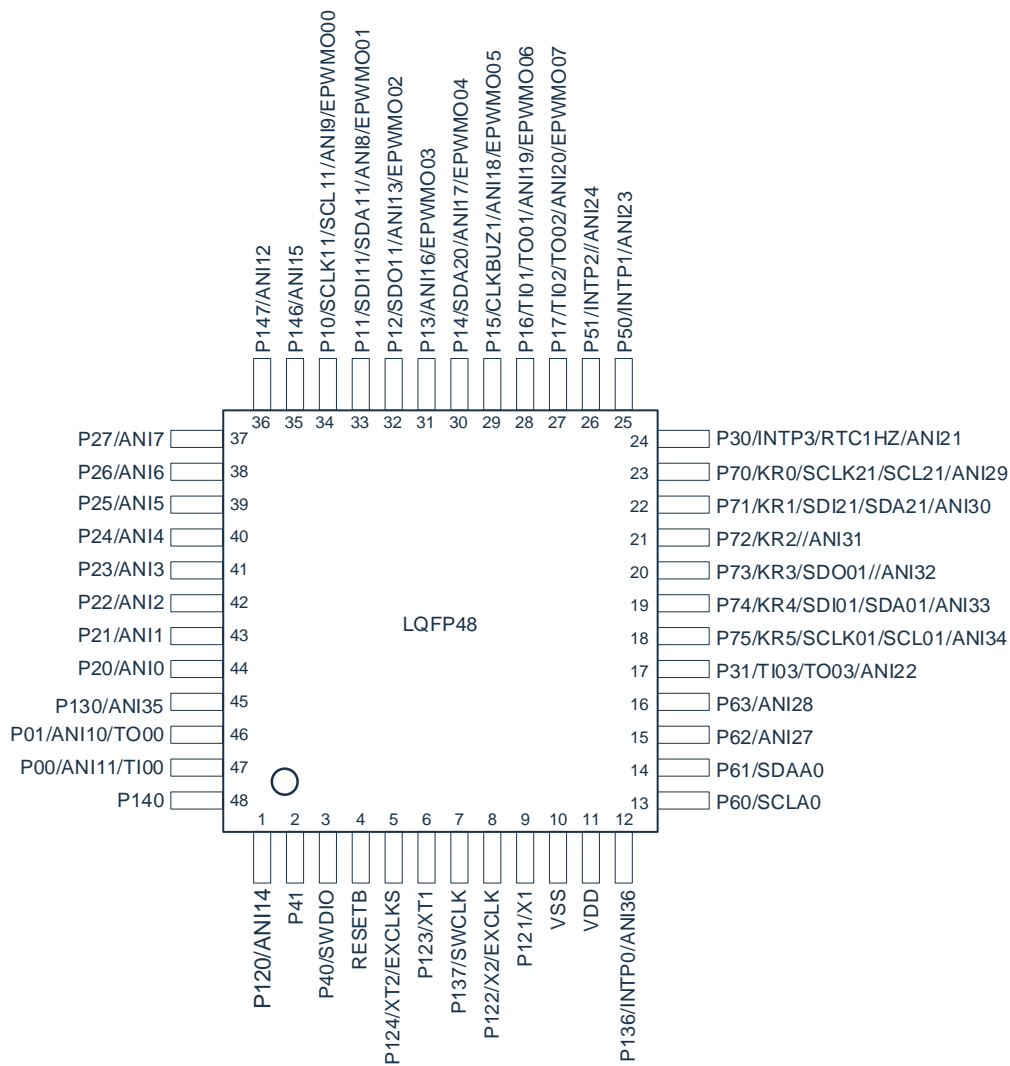

Remark: The unmarked digital function support pins in the figure are configurable, see section 4.1 for details.

2 Product Structure Diagram

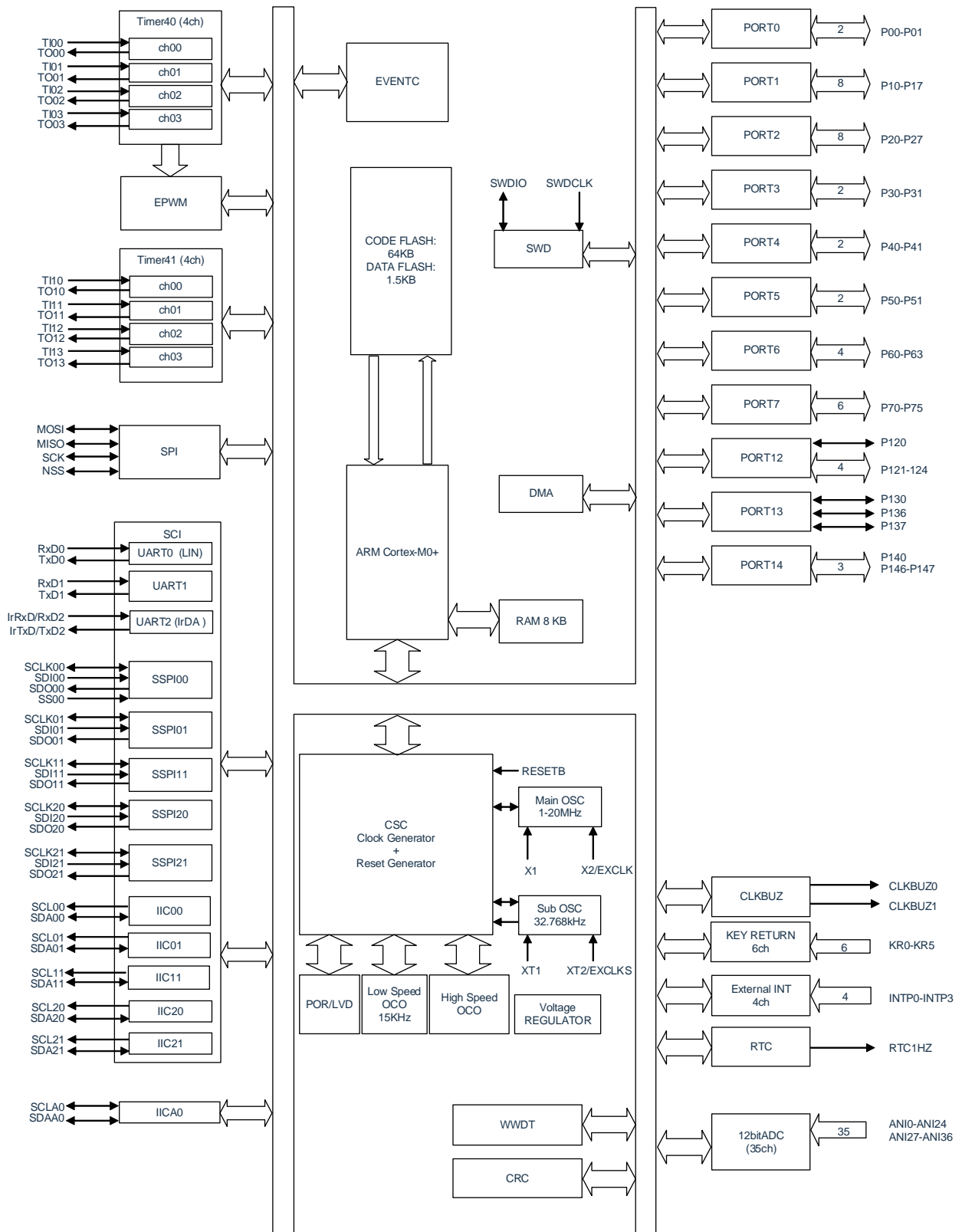

Remark: The above is for 48pin product. Some functions of products below 48pin are not supported.

3 Memory Mapping

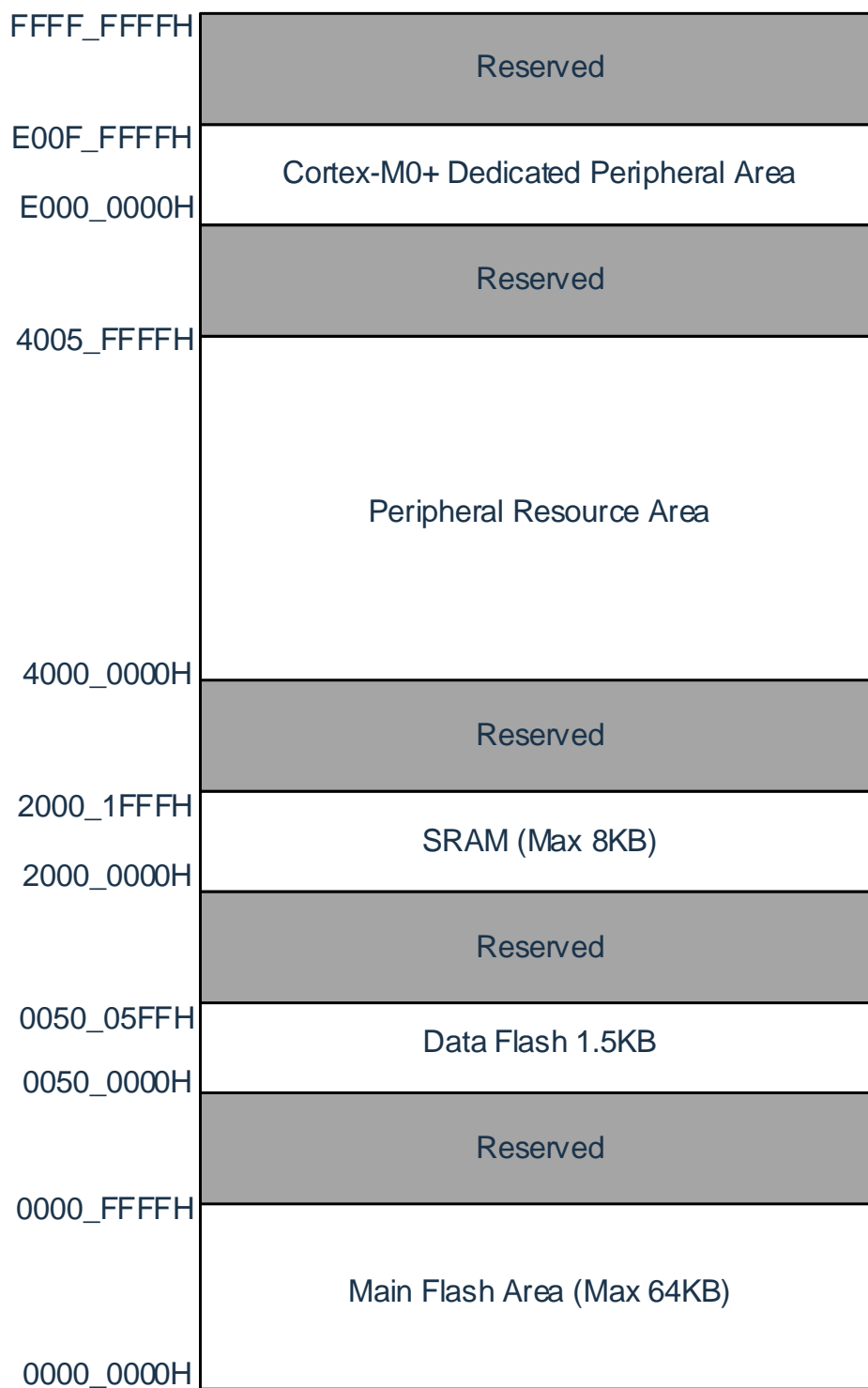

4 Pin Function

4.1 Port Function

Table 4.1.1

Port name	Port type	Reuse function	Digital output function set register pxxcfg[3:0]	Digital input function set register xxxPCFG[5:0]	Whether the function is equipped				
					48 Pin	40 Pin	32 Pin	24 Pin	20 Pin
RESETB	Type 3	RESETB	-	-	●	●	●	●	●
P00	Type 1	GPIO	00H	00H	●	●	●		
		ANI11	00H	00H	●	●	●		
		TI00	00H	00H	●	●	●		
		Configurable digital functions	X (see table 4.1.2)	X (see table 4.1.2)	●	●	●		
P01		GPIO	00H	00H	●	●	●		
		ANI10	00H	00H	●	●	●		
		TO00	00H	00H	●	●	●		
		Configurable digital functions	X (see table 4.1.2)	X (see table 4.1.2)	●	●	●		
P10		GPIO	00H	00H	●	●	●	●	●
		ANI9	00H	00H	●	●	●	●	●
		SCLK11	00H	00H	●	●	●	●	●
		SCL11	00H	00H	●	●	●	●	●
		epwmo00	00H	00H	●	●	●	●	●
P11		Configurable digital functions	X (see table 4.1.2)	X (see table 4.1.2)	●	●	●	●	●
		GPIO	00H	00H	●	●	●	●	●
		ANI8	00H	00H	●	●	●	●	●
	SDI11	00H	00H	●	●	●	●	●	
	SDA11	00H	00H	●	●	●	●	●	
	epwmo01	00H	00H	●	●	●	●	●	
P12	Configurable digital functions	X (see table 4.1.2)	X (see table 4.1.2)	●	●	●	●	●	
	GPIO	00H	00H	●	●	●	●	●	
	ANI13	00H	00H	●	●	●	●	●	
	SDO11	00H	00H	●	●	●	●	●	
	epwmo02	00H	00H	●	●	●	●	●	
P13	Configurable digital functions	X (see table 4.1.2)	X (see table 4.1.2)	●	●	●	●	●	
	GPIO	00H	00H	●	●	●	●	●	
P13	ANI16	00H	00H	●	●	●	●	●	

		epwmo03	00H	00H	●	●	●	●	●
		Configurable digital functions	X (see table 4.1.2)	X (see table 4.1.2)	●	●	●	●	●
P14		GPIO	00H	00H	●	●	●	●	●
		ANI17	00H	00H	●	●	●	●	●
		SDA20	00H	00H	●	●	●	●	●
		epwmo04	00H	00H	●	●	●	●	●
		Configurable digital functions	X (see table 4.1.2)	X (see table 4.1.2)	●	●	●	●	●
P15		GPIO	00H	00H	●	●	●	●	-
		ANI18	00H	00H	●	●	●	●	-
		CLKBUZ1	00H	00H	●	●	●	●	-
		epwmo05	00H	00H	●	●	●	●	-
		Configurable digital functions	X (see table 4.1.2)	X (see table 4.1.2)	●	●	●	●	-
P16		GPIO	00H	00H	●	●	●	-	-
		ANI19	00H	00H	●	●	●	-	-
		TI01	00H	00H	●	●	●	-	-
		TO01	00H	00H	●	●	●	-	-
		(SPIMOSI)	00H	00H	●	●	●	-	-
		epwmo06	00H	00H	●	●	●	-	-
		Configurable digital functions	X (see table 4.1.2)	X (see table 4.1.2)	●	●	●	-	-
P17	Type 1	GPIO	00H	00H	●	●	●	-	-
		ANI20	00H	00H	●	●	●	-	-
		TI02	00H	00H	●	●	●	-	-
		TO02	00H	00H	●	●	●	-	-
		(SPIMISO)	00H	00H	●	●	●	-	-
		epwmo07	00H	00H	●	●	●	-	-
		Configurable digital functions	X (see table 4.1.2)	X (see table 4.1.2)	●	●	●	-	-
P20		GPIO	00H	00H	●	●	●	●	●
		ANI0	00H	00H	●	●	●	●	●
		Configurable digital functions	X (see table 4.1.2)	X (see table 4.1.2)	●	●	●	●	●
P21		GPIO	00H	00H	●	●	●	●	●
		ANI1	00H	00H	●	●	●	●	●
		Configurable digital functions	X (see table 4.1.2)	X (see table 4.1.2)	●	●	●	●	●
P22		GPIO	00H	00H	●	●	●	●	●
		ANI2	00H	00H	●	●	●	●	●
		Configurable digital functions	X (see table 4.1.2)	X (see table 4.1.2)	●	●	●	●	●
P23		GPIO	00H	00H	●	●	●	●	●

		ANI3	00H	00H	●	●	●	●	●
		Configurable digital functions	X (see table 4.1.2)	X (see table 4.1.2)	●	●	●	●	●
	P24	GPIO	00H	00H	●	●	-	●	-
ANI4		00H	00H	●	●	-	●	-	
		Configurable digital functions	X (see table 4.1.2)	X (see table 4.1.2)	●	●	-	●	-
P25	Type 1	GPIO	00H	00H	●	●	-	-	-
		ANI5	00H	00H	●	●	-	-	-
		Configurable digital functions	X (see table 4.1.2)	X (see table 4.1.2)	●	●	-	-	-
P26	Type 1	GPIO	00H	00H	●	-	-	-	-
		ANI6	00H	00H	●	-	-	-	-
		Configurable digital functions	X (see table 4.1.2)	X (see table 4.1.2)	●	-	-	-	-
P27	Type 1	GPIO	00H	00H	●	-	-	-	-
		ANI7	00H	00H	●	-	-	-	-
		Configurable digital functions	X (see table 4.1.2)	X (see table 4.1.2)	●	-	-	-	-
P30	Type 1	GPIO	00H	00H	●	●	●	-	-
		ANI21	00H	00H	●	●	●	-	-
		INTP3	00H	00H	●	●	●	-	-
		RTC1HZ	00H	00H	●	●	●	-	-
		Configurable digital functions	X (see table 4.1.2)	X (see table 4.1.2)	●	●	●	-	-
P31	Type 1	GPIO	00H	00H	●	●	●	-	-
		ANI22	00H	00H	●	●	●	-	-
		TI03	00H	00H	●	●	●	-	-
		TO03	00H	00H	●	●	●	-	-
		Configurable digital functions	X (see table 4.1.2)	X (see table 4.1.2)	●	●	●	-	-
P40	Type 1	GPIO	00H	00H	●	●	●	●	●
		SWDIO	00H	00H	●	●	●	●	●
		Configurable digital functions	X (see table 4.1.2)	X (see table 4.1.2)	●	●	●	●	●
P41	Type 1	GPIO	00H	00H	●	-	-	-	-
		Configurable digital functions	X (see table 4.1.2)	X (see table 4.1.2)	●	-	-	-	-
P50	Type 1	GPIO	00H	00H	●	●	●	-	-
		ANI23	00H	00H	●	●	●	-	-
		INTP1	00H	00H	●	●	●	-	-
		(SPINSS)	00H	00H	●	●	●	-	-
		Configurable digital functions	X (see table 4.1.2)	X (see table 4.1.2)	●	●	●	-	-
P51	Type 1	GPIO	00H	00H	●	●	●	-	-

		ANI24	00H	00H	●	●	●	-	-
		INTP2	00H	00H	●	●	●	-	-
		(SPISCK)	00H	00H	●	●	●	-	-
		Configurable digital functions	X (see table 4.1.2)	X (see table 4.1.2)	●	●	●	-	-
P60		GPIO	00H	00H	●	●	-	-	-
		Configurable digital functions	X (see table 4.1.2)	X (see table 4.1.2)	●	●	-	-	-
P61		GPIO	00H	00H	●	●	-	-	-
		Configurable digital functions	X (see table 4.1.2)	X (see table 4.1.2)	●	●	-	-	-
P62		GPIO	00H	00H	●	-	-	-	-
		ANI27	00H	00H	●	-	-	-	-
P63		Configurable digital functions	X (see table 4.1.2)	X (see table 4.1.2)	●	-	-	-	-
		GPIO	00H	00H	●	-	-	-	-
		ANI28	00H	00H	●	-	-	-	-
P70		Configurable digital functions	X (see table 4.1.2)	X (see table 4.1.2)	●	-	-	-	-
		GPIO	00H	00H	●	●	●	●	-
		ANI29	00H	00H	●	●	●	●	-
		KR0	00H	00H	●	●	-	●	-
		SCLK21	00H	00H	●	-	-	●	-
P71	Type 1	SCL21	00H	00H	●	-	-	●	-
		Configurable digital functions	X (see table 4.1.2)	X (see table 4.1.2)	●	●	●	●	-
		GPIO	00H	00H	●	-	-	●	-
		ANI30	00H	00H	●	-	-	●	-
		KR1	00H	00H	●	-	-	●	-
		SDI21	00H	00H	●	-	-	●	-
		SDA21	00H	00H	●	-	-	●	-
P72		Configurable digital functions	X (see table 4.1.2)	X (see table 4.1.2)	●	-	-	●	-
		GPIO	00H	00H	●	●	●	●	-
		ANI31	00H	00H	●	●	●	●	-
		KR2	00H	00H	●	●	-	●	-
		SDO21	00H	00H	●	-	-	●	-
P73		Configurable digital functions	X (see table 4.1.2)	X (see table 4.1.2)	●	●	●	●	-
		GPIO	00H	00H	●	●	●	●	-
		ANI32	00H	00H	●	●	●	●	-
		KR3	00H	00H	●	●	-	●	-
		SDO01	00H	00H	●	●	-	●	-
		Configurable digital functions	X (see table 4.1.2)	X (see table 4.1.2)	●	●	●	●	-

P74		GPIO	00H	00H	●	●	●	●	-
		ANI33	00H	00H	●	●	●	●	-
		KR4	00H	00H	●	●	-	●	-
		SDI01	00H	00H	●	●	-	●	-
		SDA01	00H	00H	●	●	-	●	-
		Configurable digital functions	X (see table 4.1.2)	X (see table 4.1.2)	●	●	●	●	-
P75		GPIO	00H	00H	●	●	-	●	-
		ANI34	00H	00H	●	●	-	●	-
		KR5	00H	00H	●	●	-	●	-
		SCLK01	00H	00H	●	●	-	●	-
		SCL01	00H	00H	●	●	-	●	-
		Configurable digital functions	X (see table 4.1.2)	X (see table 4.1.2)	●	●	-	●	-
P120	Type 1	GPIO	00H	00H	●	●	●	-	-
		ANI14	00H	00H	●	●	●	-	-
		Configurable digital functions	X (see table 4.1.2)	X (see table 4.1.2)	●	●	●	-	-
P121		GPIO	00H	00H	●	●	●	●	●
		X1	00H	00H	●	●	●	●	●
		Configurable digital functions	X (see table 4.1.2)	X (see table 4.1.2)	●	●	●	●	●
P122		GPIO	00H	00H	●	●	●	●	●
		X2	00H	00H	●	●	●	●	●
		EXCLK	00H	00H	●	●	●	●	●
		Configurable digital functions	X (see table 4.1.2)	X (see table 4.1.2)	●	●	●	●	●
P123		GPIO	00H	00H	●	●	-	-	●
		XT1	00H	00H	●	●	-	-	●
		Configurable digital functions	X (see table 4.1.2)	X (see table 4.1.2)	●	●	-	-	●
P124		GPIO	00H	00H	●	●	-	-	●
		XT2	00H	00H	●	●	-	-	●
		EXCLKS	00H	00H	●	●	-	-	●
		Configurable digital functions	X (see table 4.1.2)	X (see table 4.1.2)	●	●	-	-	●
P130		GPIO	00H	00H	●	-	-	-	-
		ANI35	00H	00H	●	-	-	-	-
		Configurable digital functions	X (see table 4.1.2)	X (see table 4.1.2)	●	-	-	-	-
P136	Type 1	GPIO	00H	00H	●	●	●	-	●
		ANI36	00H	00H	●	●	●	-	●
		INTP0	00H	00H	●	●	●	-	●
		Configurable digital functions	X (see table 4.1.2)	X (see table 4.1.2)	●	●	●	-	●

P137		GPIO	00H	00H	●	●	●	●	●
		SWCLK	00H	00H	●	●	●	●	●
		Configurable digital functions	X (see table 4.1.2)	X (see table 4.1.2)	●	●	●	●	●
P140		GPIO	00H	00H	●	●	-	-	-
		Configurable digital functions	X (see table 4.1.2)	X (see table 4.1.2)	●	●	-	-	-
P146		GPIO	00H	00H	●	-	-	-	-
		ANI15	00H	00H	●	-	-	-	-
		Configurable digital functions	X (see table 4.1.2)	X (see table 4.1.2)	●	-	-	-	-
P147		GPIO	00H	00H	●	●	●	-	-
		ANI12	00H	00H	●	●	●	-	-
		Configurable digital functions	X (see table 4.1.2)	X (see table 4.1.2)	●	●	●	-	-
V _{DD}	-	Power supply	-	-	●	●	●	●	●
V _{SS}	-	Ground	-	-	●	●	●	●	●

Remark: Refer to Section 4.3 for type 1, type 2 and type 3 port type structure diagrams.

Table 4.1.2 Digital function configuration list (1/2 output function configuration)

Pin	Control register	Register configuration	Pin dual-purpose function
P00~P147	P00cfg[3:0]~P147cfg[3:0]	4'h00	Default dual-use output
		4'h01	TO10
		4'h02	TO11
		4'h03	TO12
		4'h04	TO13
		4'h05	SDO00/TxD0
		4'h06	SDO20/TxD2
		4'h07	CLKBUZ0
		4'h08	SCLKO00
		4'h09	SCLKO20
		4'h0a	TxD1

Remark: P60 and P61 are NOD output, please pay attention when configuring and using.

Table 4.1.2 Digital function configuration list (2/2 input function configuration)

Control register	Register configuration	Pin dual-purpose function
TI10PCFG	6'h00	Default dual-purpose input
TI11PCFG	6'h01	P00 as a dual input
TI12PCFG	6'h02	P01 as a dual input
TI13PCFG	6'h03	P10 as a dual input
INTP0PCFG	6'h04	P11 as a dual input
INTP1PCFG	6'h05	P12 as a dual input
INTP2PCFG	6'h06	P13 as a dual input
INTP3PCFG	6'h07	P14 as a dual input
SDI00PCFG (SPI/IIC/UART)	6'h08	P15 as a dual input
SCLKI00PCFG (SPI/IIC)	6'h09	P16 as a dual input
SS00PCFG (SPI)	6'h0a	P17 as a dual input
SDI20PCFG (SPI/UART)	6'h0b	P20 as a dual input
SCLKI20PCFG (SPI)	6'h0c	P21 as a dual input
RXD1PCFG (UART)	6'h0d	P22 as a dual input
SDAA0PCFG	6'h0e	P23 as a dual input
SCLA0PCFG	6'h0f	P24 as a dual input
	6'h10	P25 as a dual input
	6'h11	P26 as a dual input
	6'h12	P27 as a dual input
	6'h13	P30 as a dual input
	6'h14	P31 as a dual input
	6'h15	P40 as a dual input
	6'h16	P41 as a dual input
	6'h17	P50 as a dual input
	6'h18	P51 as a dual input

	6'h19	P60 as a dual input
	6'h1a	P61 as a dual input
	6'h1b	P62 as a dual input
	6'h1c	P63 as a dual input
	6'h1d	P70 as a dual input
	6'h1e	P71 as a dual input
	6'h1f	P72 as a dual input
	6'h20	P73 as a dual input
	6'h21	P74 as a dual input
	6'h22	P75 as a dual input
	6'h23	P120 as a dual input
	6'h24	P121 as a dual input
	6'h25	P122 as a dual input
	6'h26	P123 as a dual input
	6'h27	P124 as a dual input
	6'h28	P130 as a dual input
	6'h29	P136 as a dual input
	6'h2a	P137 as a dual input
	6'h2b	P140 as a dual input
	6'h2c	P146 as a dual input
	6'h2d	P147 as a dual input

Table 4.1.3 SPI pin function configuration list

Register name	Register settings	SPI pin function mapping relationship			
		SPINSS	SPISCK	SPIMISO	SPIMOSI
SPIPCFG [1:0]	2'b00	Not mapped to any pins			
	2'b01	P50	P51	P17	P16
	2'b10	P63	P31	P75	P74
	2'b11	P25	P24	P23	P22

4.2 Port Multiplexing Function

(1/2)

Function name	Input/output	Function
ANI0 ~ANI36	input	Analog input of A/D converter
INTP0 ~INTP3	input	External interrupt request input Designation of valid edges: rising edge, falling edge, rising and falling double edges
KR0 ~KR5	input	Key interrupt input
CLKBUZ0, CLKBUZ1	output	Clock output / buzzer output
RTC1HZ	output	Real-time clock correction clock (1Hz) output
RESETB	input	Low-level active system reset input. When external reset is not used, it must be connected to V _{DD} directly or through a resistor.
IrRxD	input	IrDA serial data input
IrTxD	output	IrDA serial data output
RxD0 ~RxD2	input	Serial data input of serial interface UART0, UART1, UART2
TxD0 ~TxD2	output	Serial data output of serial interface UART0, UART1, UART2
SCL00, SCL01, SCL11 SCL20, SCL21	output	Serial clock output of serial interface IIC00, IIC01, IIC11, IIC20, IIC21
SDA00, SDA01, SDA11 SDA20, SDA21	input/ output	Serial data input/ output of serial interface IIC00, IIC01, IIC11, IIC20, IIC21
SCLK00, SCLK01, SCLK11 SCLK20, SCLK21	input/ output	Serial clock input/ output of serial interface SSPI00, SSPI01, SSPI11, SSPI20, SSPI21
SDI00, SDI01, SDI11, SDI20 SDI21	input	Serial data input of serial interface SSPI00, SSPI01, SSPI11, SSPI20, SSPI21

(2/2)

Function name	Input/output	Function
SS00	input	Chip select input of serial interface SSPI00
SDO00, SDO01, SDO11, SDO20, SDO21	output	Serial data output of SSPI00, SSPI01, SSPI11, SSPI20, SSPI21
SPINSS	input	Chip select input of serial interface SPI
SPISCK	Input/ output	Serial clock input/output of serial interface SPI
SPIMISO	Input/ output	Serial data input/output of serial interface SPI
SPIMOSI	Input/ output	Serial data input/output of serial interface SPI
SCLA0	Input/ output	Clock input/output of serial interface IICA0
SDAA0	Input/ output	Serial data input/output of serial interface IICA0
TI00~TI03	input	16-bit timer Timer40 external count clock/capture trigger input
TO00~TO03	output	Timer output of 16-bit timer Timer40
TI10~TI13	input	16-bit timer Timer41 external count clock/capture trigger input
TO10~TO13	output	Timer output of 16-bit timer Timer41
X1, X2	—	Connect the resonator for the main system clock.
EXCLK	input	External clock input of main system clock
XT1, XT2	—	Connect the resonator for the subsystem clock.
EXCLKS	input	External clock input for subsystem clock
V _{DD}	—	Power supply
V _{SS}	—	Ground
SWDIO	input / output	SWD data interface
SWCLK	input	SWD clock interface

Remark: As a countermeasure for noise and locking, the bypass capacitor (about 0.1uF) must be connected with the shortest distance between V_{DD} and V_{SS} and thicker wiring.

4.3 Port Type

Type 1: Dual I/O function

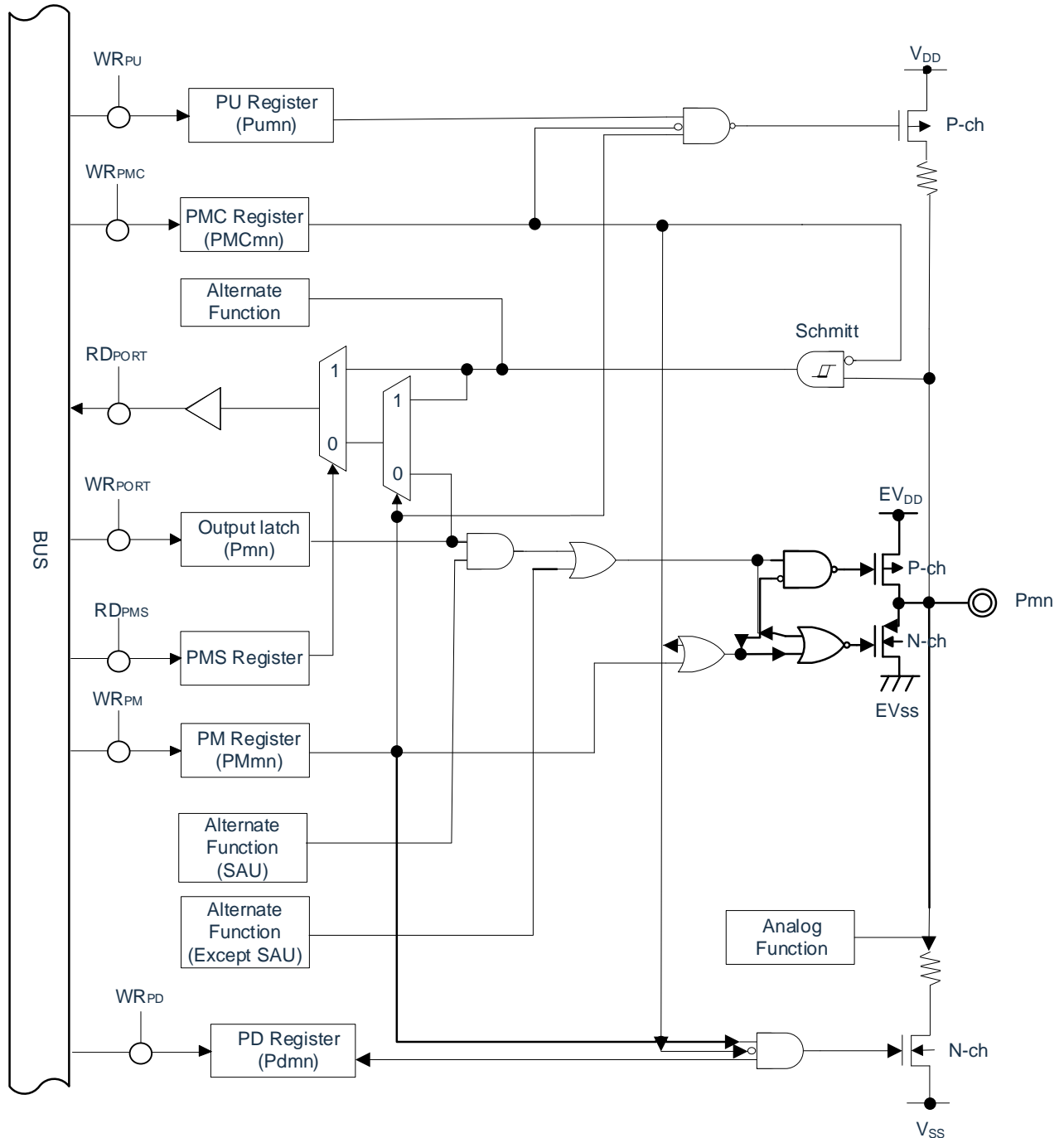

Type 2: CLK input function

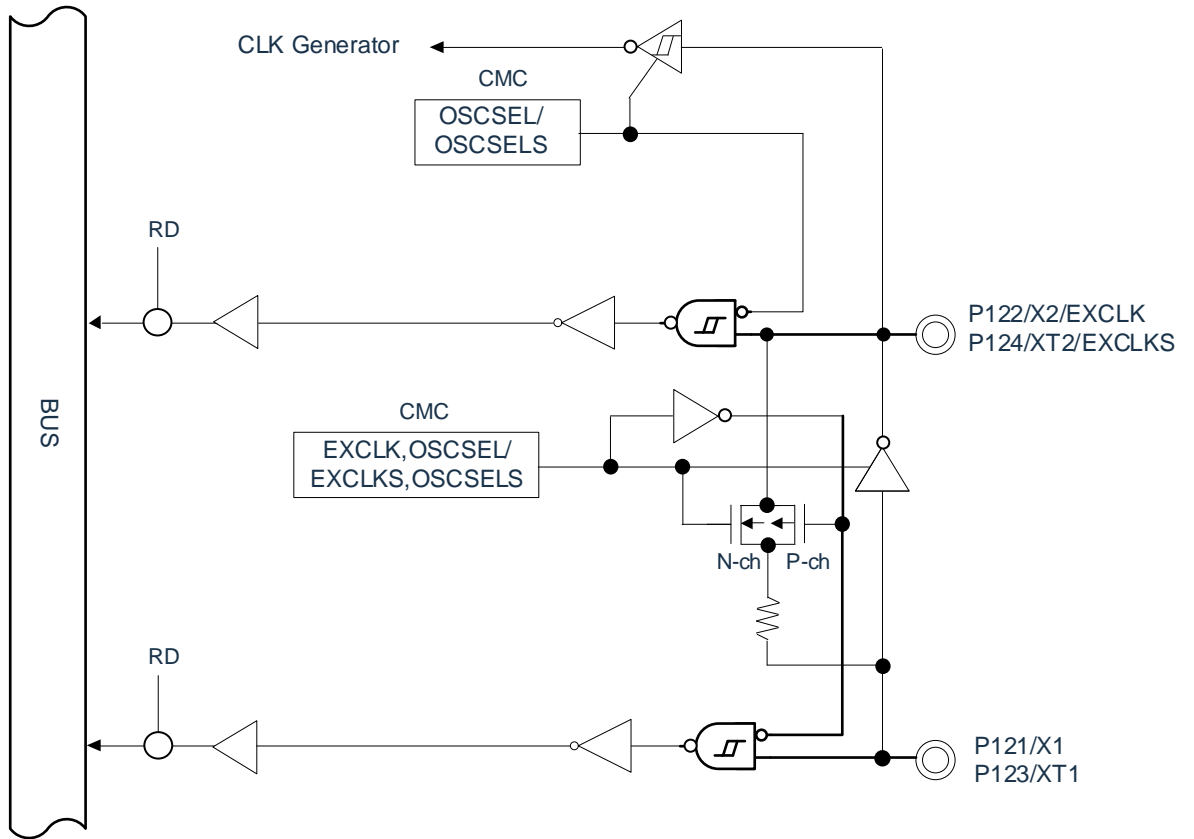

Type 3: RESET function

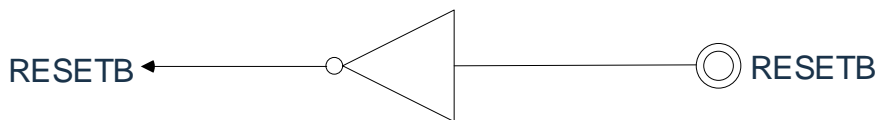

5 Function Summary

5.1 ARM® Cortex®-M0+ Core

ARM's Cortex-M0+ processor is a new generation of ARM processors for embedded systems. It provides a low-cost platform designed to meet the needs of a small pin count and low-power microcontroller, while providing excellent computing performance and advanced system response to interrupts.

The 32-bit RISC processor of the Cortex-M0+ processor provides excellent code efficiency and the expected high performance of the ARM core, which is different from 8-bit and 16-bit devices of the same memory size. The Cortex-M0+ processor has 32 address lines and a storage space of up to 4G.

CMS32L051 uses an embedded ARM core, so it is compatible with all ARM tools and software.

5.2 Memory

5.2.1 Flash

CMS32L051 has a built-in flash memory that can be programmed, erased and rewritten. Has the following functions:

- Programs and data share 64K storage space.
- 1.5KB dedicated data Flash memory.
- Support page erasing, each page size is 512byte.
- Support byte/half-word/word (32bit) programming.

5.2.2 SRAM

CMS32L051 has built-in 8K bytes of embedded SRAM.

5.3 Enhanced DMA Controller

Built-in enhanced DMA (Direct Memory Access) controller can realize the function of data transfer between memories without using CPU.

- It supports the start of DMA through peripheral function interrupts, and can realize real-time control through communication, timer and A/D.
- The transmission source/destination area is optional for the entire address space range (when the Flash area is used as the destination address, the Flash needs to be preset to the programming mode).
- Supports 4 transfer modes (normal transfer mode, repetitive transfer mode, block transfer mode and chain transfer mode).

5.4 Linkage Controller

The linkage controller links each peripheral function output event with the peripheral function trigger source. So as to realize the coordinated operation between peripheral functions without using the CPU.

The linkage controller has the following functions:

- The event signals can be linked together to realize the linkage of peripheral functions.
- 15 types of event input, 4 types of event trigger.

5.5 Clock Generation and Start

The clock generation circuit is a circuit that generates a clock for the CPU and peripheral hardware. There are the following 3 types of system clocks and clock oscillation circuits.

5.5.1 Main System Clock

- X1 oscillator circuit: It can generate 1-20MHz clock oscillation by connecting a resonator to the pins (X1 and X2), and can stop the oscillation by executing a deep sleep command or setting MSTOP.
- High-speed internal oscillator (high-speed OCO): The frequency can be selected for oscillation by the option byte. After the reset is released, the CPU defaults to start running with this high-speed internal oscillator clock. Oscillation can be stopped by executing a deep sleep instruction or setting the HIOSTOP bit. The frequency set by the option byte can be changed through the frequency selection register of the high-speed internal oscillator. The highest frequency is 64Mhz, and the accuracy is $\pm 1.0\%$.
- Input the external clock from the pin (X2): (1~20MHz), and the input of the external main system clock can be disabled by executing the deep sleep instruction or setting the MSTOP bit.

5.5.2 Subsystem Clock

- XT1 oscillator circuit: It can generate 32.768KHz clock oscillation by connecting a 32.768KHz resonator to the pins (XT1 and XT2), and the oscillation can be stopped by setting the XTSTOP bit.
- Input the external clock from the pin (XT2): 32.768KHz, and the input of the external clock can be disabled by setting the XTSTOP bit.

5.5.3 Low-speed Internal Oscillator Clock

Low-speed internal oscillator (low-speed OCO): generates 15KHz (Typ.) clock oscillation. The low-speed internal oscillator clock can be used as the CPU clock. The following peripheral hardware can be run by the low-speed internal oscillator clock:

- Watchdog timer (WWDT)
- Real Time Clock (RTC)
- 15-bit interval timer

5.6 Power Management

5.6.1 Power Supply Mode

V_{DD} : external power supply, voltage range 1.8 to 5.5V

5.6.2 Power-on Reset

The power-on reset circuit (POR) has the following functions:

- An internal reset signal is generated when the power is turned on. If the power supply voltage (V_{DD}) is greater than the detection voltage (V_{POR}), the reset is released. However, before reaching the operating voltage range, the reset state must be maintained through a voltage detection circuit or an external reset.
- The power supply voltage (V_{DD}) and the detection voltage (V_{PDR}) are compared. When $V_{DD} < V_{PDR}$, an internal reset signal is generated. However, when the power supply drops, it must be shifted to the deep sleep mode before it falls below the operating voltage range, or set to the reset state through a voltage detection circuit or an external reset. If you want to restart operation, you must confirm that the power supply voltage has returned to the operating voltage range.

5.6.3 Voltage Detection

The voltage detection circuit sets the operation mode and detection voltage (V_{LVDH} , V_{LVDL} , V_{LVD}) through the option byte. The voltage detection (LVD) circuit has the following functions:

- Compare the power supply voltage (V_{DD}) with the detection voltage (V_{LVDH} , V_{LVDL} , V_{LVD}) and generate an internal reset or interrupt request signal.
- The detection voltage of the power supply voltage (V_{LVDH} , V_{LVDL} , V_{LVD}) can select the detection level by the option byte.
- Can run in deep sleep mode.
- When the power supply rises, before reaching the operating voltage range, the reset state must be maintained through a voltage detection circuit or an external reset. When the power supply drops, it must be transferred to the deep sleep mode before being lower than the operating voltage range, or set to the reset state through a voltage detection circuit or an external reset.
- The operating voltage range varies according to the setting of the user option byte.

5.7 Low Power Consumption Mode

CMS32L051 supports two low-power modes to achieve the best compromise between low power consumption, short startup time, and available wake-up sources.

- Sleep mode: Enter the sleep mode by executing the sleep command. The sleep mode is a mode in which the CPU operating clock is stopped. Before setting the sleep mode, if the high-speed system clock oscillator circuit, high-speed internal oscillator, or subsystem clock oscillator circuit is oscillating, each clock continues to oscillate. Although this mode cannot reduce the operating current to the level of the deep sleep mode, it is an effective mode when you want to restart processing immediately through an interrupt request or when you want to perform intermittent operation frequently.
- Deep sleep mode: Enter the deep sleep mode by executing the deep sleep command. The deep sleep mode is a mode to stop the oscillation of the high-speed system clock oscillation circuit and the high-speed internal oscillator and stop the entire system. Can greatly reduce the operating current of the chip. Because the deep sleep mode can be cancelled by an interrupt request, intermittent operation is also possible. However, in the case of the X1 clock, because it is necessary to ensure the wait time for stable oscillation when releasing the deep sleep mode, if you must start processing immediately with an interrupt request, you must select the sleep mode.

In the two low-power modes mentioned above, the registers, flags, and data memory remain in the state before standby mode, and the output latch and output buffer of the input/output ports will also remain in the state before standby.

5.8 Reset Function

The following 7 methods to generate a reset signal:

- 1) Input external reset through RESETB pin.
- 2) Generate an internal reset through the program runaway detection of the watchdog timer.
- 3) The internal reset is generated by comparing the power supply voltage of the power-on reset (POR) circuit and the detection voltage.
- 4) The internal reset is generated by comparing the power supply voltage of the voltage detection circuit (LVD) and the detection voltage.
- 5) Internal reset due to RAM parity error.
- 6) Internal reset due to access to illegal memory.
- 7) Software reset

The internal reset is the same as the external reset. After the reset signal is generated, the program is executed from the addresses written in addresses 0000H and 0001H.

5.9 Interrupt Function

The Cortex-M0+ processor has a built-in nested vectored interrupt controller (NVIC), which supports up to 32 interrupt request (IRQ) inputs and 1 non-maskable interrupt (NMI) input. In addition, the processor also supports multiple internal exceptions.

This product has processed 32 maskable interrupt requests (IRQ) and 1 non-maskable interrupt (NMI). For details, please refer to the corresponding chapters of the user manual. The actual number of interrupt sources varies by product.

5.10 Real Time Clock (RTC)

The real-time clock (RTC) has the following functions.

- Counter with year, month, week, day, hour, minute and second.
- Fixed period interrupt function (period: 0.5 second, 1 second, 1 minute, 1 hour, 1 day, 1 month)
- Alarm interrupt function (alarm clock: week, hour, minute)
- 1Hz pin output function
- Support the division of the subsystem clock or the main system clock as the running clock of the RTC
- The real-time clock interrupt signal (INTRTC) can be used as a wake-up from deep sleep mode
- Support a wide range of clock correction functions

Only when the sub-system clock (32.768KHz) or the divided frequency of the main system clock is selected as the running clock of the RTC, the year, month, week, day, hour, minute and second can be counted. When the low-speed internal oscillator clock (15KHz) is selected, only the fixed cycle interrupt function can be used.

5.11 Watchdog Timer

1 channel WWDT, 17bit watchdog timer is set to count operation by option byte. The watchdog timer runs on the low-speed internal oscillator clock (15KHz). The watchdog timer is used to detect program runaway. When a program out of control is detected, an internal reset signal is generated.

The following conditions are judged to be out of control of the program:

- When the watchdog timer counter overflows
- When a 1-bit operation instruction is executed on the enable register (WDTE) of the watchdog timer
- When writing data other than "ACH" to the WDTE register
- When writing data to the WDTE register while the window is closed

5.12 SysTick Timer

This timer is dedicated to the real-time operating system, but it can also be used as a standard down counter.

Its characteristics are: when the 24-bit down counter self-filling capacity counter reaches 0, a maskable system interrupt is generated.

5.13 Timer Timer4

This product has two built-in timer units Timer4 with 4-channel 16-bit timers each 16-bit timer is called a “channel”, which can be used as an independent timer or combined with multiple channels for advanced timer functions.

For details of each function, please refer to the table below:

Independent channel operation function	Multi-channel linkage operation function
<ul style="list-style-type: none"> ● Interval timer ● Square wave output ● External event counter ● Frequency divider ● Measurement of input pulse interval ● Measurement of the high/low level width of the input signal ● Delay counter 	<ul style="list-style-type: none"> ● One-shot pulse output ● PWM output ● Multiple PWM output

5.13.1 Independent Channel Operation Function

The independent channel operation function is a function that can independently use any channel without being affected by the operation mode of other channels. The independent channel operation function can be used in the following modes:

- 1) Interval timer: Can be used as a reference timer that generates interrupts (INTTM) at regular intervals.
- 2) Square wave output: Whenever an INTTM interrupt is generated, a flip is triggered, and a square wave with a 50% duty cycle is output from the timer output pin (TO).
- 3) External event counter: Count the valid edge of the input signal of the timer input pin (TI), and if it reaches the specified number of times, it can be used as an event counter to generate an interrupt.
- 4) Frequency divider function (only limited to channel 0 of unit 0): divide the input clock of the timer input pin (TI00), and then output from the output pin (TO00).
- 5) Input pulse interval measurement: start counting at the valid edge of the input pulse signal of the timer input pin (TI) and capture the count value at the valid edge of the next pulse to measure the interval of the input pulse.
- 6) Measurement of the high/low level width of the input signal: start counting on one edge of the input signal of the timer input pin (TI) and capture the count value on the other edge to measure the high or low level of the input signal Width.
- 7) Delay counter: start counting at the valid edge of the input signal of the timer input pin (TI) and generate an interrupt after any delay period has elapsed.

5.13.2 Multi-channel Linkage Operation Function

Multi-channel linkage operation function can be realized by combining the master channel (the basic timer of the main control cycle) and the slave channel (the timer that follows the master control channel). Multi-channel linkage operation function can be used in the following modes:

- 1) One-shot pulse output: Use two channels in pairs to generate one-shot pulses that can set the output timing and pulse width arbitrarily.
- 2) PWM (Pulse Width Modulation) output: Use 2 channels in pairs to generate pulses with a period and duty cycle that can be set arbitrarily.
- 3) Multiple PWM (Pulse Width Modulation) output: It can generate up to 7 kinds of PWM signals with any duty cycle in a fixed cycle by expanding the PWM function and using 1 master channel and multiple slave channels.

5.13.3 8-bit Timer Operation Function

The 8-bit timer operation function can use the 16-bit timer channel as a function of two 8-bit timer channels. (Only channel 1 and channel 3 can be used)

5.13.4 LIN-bus Support Function

The Timer4 unit can be used to check whether the received signal in LIN-bus communication is suitable for the LIN-bus communication format.

- 1) Wake-up signal detection: Start counting on the falling edge of the input signal of the UART serial data input pin (RxD) and capture the count value on the rising edge to measure the low-level width. If the low-level width is greater than or equal to a certain fixed value, it is considered as a wake-up signal.
- 2) Interval field detection: After detecting the wake-up signal, start counting from the falling edge of the input signal of the UART serial data input pin (RxD) and capture the count value on the rising edge to measure the low-level width. If the width of the low level is greater than or equal to a certain fixed value, it is regarded as an interval field.
- 3) Synchronous field pulse width measurement: After detecting the interval field, measure the low-level width and high-level width of the input signal of the UART serial data input pin (RxD). Calculate the baud rate based on the bit interval of the sync field measured in this way.

5.14 EPWM Output Control Circuit

Use Timer4's PWM output function to control one DC motor or two stepping motors.

5.15 15-bit Interval Timer

This product has a built-in 15-bit interval timer, which can generate interrupts (INTIT) at any time interval set in advance, and can be used to wake up from deep sleep mode.

5.16 Clock Output/Buzzer Output Control Circuit

The clock output controller is used to provide the clock to the peripheral IC, and the buzzer output controller is used to output the square wave of the buzzer frequency. Clock output or buzzer output is realized by dedicated pins.

5.17 Universal Serial Communication Unit

This product has two built-in universal serial communication units, and each unit has up to 4 serial communication channels. It can realize the communication functions of standard SPI, simple SPI, UART and simple I²C. Take the 48pin product as an example, the function allocation of each channel is as follows.

5.17.1 3-wire Serial Interface (Simple SPI)

Synchronize data transmission and reception with the serial clock (SCK) output from the master control device.

This is a clock synchronous communication interface that uses 1 serial clock (SCK), 1 sending serial data (SO), and 1 receiving serial data (SI) to communicate with a total of 3 communication lines.

[Data transmission and reception]

- 7-bit or 8-bit data length
- Phase control of sending and receiving data
- MSB/LSB priority choice

[Clock control]

- Choice of master control or slave
- Phase control of input/output clock
- The transmission cycle generated by the prescaler and the internal counter of the channel
- Maximum transfer rate

Master communication: Max $F_{CLK}/2$

Slave communication: Max $F_{MCK}/6$

[Interrupt function]

- Transmission end interrupt, buffer empty interrupt

[Error detection flag]

- Overflow error

5.17.2 Simple SPI with Slave Chip Select Function

SPI serial communication interface supporting slave chip select input function. This is a clock synchronization that uses a slave chip select input (SS1), a serial clock (SCK), a sending serial data (SO), and a receiving serial data (SI) 4 communication lines for communication. Communication Interface.

[Data sending and receiving]

- 7-bit or 8-bit data length
- Phase control of sending and receiving data
- MSB/LSB priority choice
- Level setting of sending and receiving data

[Clock control]

- Phase control of input/output clock
- The transmission cycle generated by the prescaler and the internal counter of the channel
- Maximum transfer rate

Slave communication: Max $F_{MCK}/6$

[Interrupt function]

- Transmission end interrupt, buffer empty interrupt

[Error detection flag]

- Overflow error

5.17.3 UART

The function of asynchronous communication through two lines of serial data transmission (TxD) and serial data reception (RxD). Use these two communication lines to send and receive data asynchronously (using the internal baud rate) with other communication parties according to the data frame (consisting of start bit, data, parity bit and stop bit). Full-duplex UART communication can be realized by using two channels dedicated for transmission (even-numbered channels) and dedicated for reception (odd-numbered channels), and LIN-bus can be supported by combining Timer4 units and external interrupts (INTP0).

[Data sending and receiving]

- 7-bit, 8-bit or 9-bit data length
- MSB/LSB priority choice
- Selection of level setting and reverse phase of sending and receiving data
- Additional parity check bit, parity check function
- Additional stop bit, stop bit detection

[Interrupt function]

- Transmission end interrupt, buffer empty interrupt
- Error interrupt caused by framing error, parity error or overflow error

[Error detection flag]

- Frame error, parity error, overflow error

[LIN-bus function]

- Wake-up signal detection
- BF detection
- Measurement of synchronization field, calculation of baud rate

5.17.4 Simple I²C

The function of clock synchronization communication with multiple devices through two lines of serial clock (SCL) and serial data (SDA). Because this simple I²C is designed for single communication with flash memory, A/D converters and other devices, it can only be used as a master device. The start condition and stop condition are the same as the operation control register, and must comply with the AC characteristics and be processed by software.

[Data sending and receiving]

- Main control sending, main control receiving (only limited to the main control function of single main control)
- ACK output function, ACK detection function
- 8-bit data length (when sending the address, use the upper 7 bits to specify the address, and use the lowest bit for R/W control)
- Generate start and stop conditions through software

[Interrupt function]

- End of transmission interrupt

[Error detection flag]

- ACK error, overflow error

[Functions not supported by simple I²C]

- Slave sending, slave receiving
- Multi-master control function (arbitration failure detection function)
- Waiting for detection function

5.18 Standard Serial Peripheral Interface (SPI)

The serial interface SPI has the following 2 modes:

- Operation stop mode: This is a mode used when serial transmission is not performed, which can reduce power consumption
- 3-wire serial I/O mode: This mode uses 3 lines of serial clock (SCK) and serial data bus (MISO and MOSI) to transmit 8-bit or 16-bit data with multiple devices.

5.19 Standard Serial Interface (IICA)

The serial interface IICA has the following 3 modes:

- Operation stop mode: This is a mode used when serial transmission is not performed, which can reduce power consumption.
- I²C bus mode (supports multiple masters): This mode uses 2 lines of serial clock (SCLA) and serial data bus (SDAA) to transmit 8-bit data with multiple devices. In line with the I²C bus format, the master device can generate “start condition”, “address”, “indication of the transfer direction”, “data” and “stop condition” for the slave device on the serial data bus. The slave device automatically detects the received status and data through hardware. This function can simplify the I²C bus control part of the application. Because the SCLA pin and SDAA pin of the serial interface IICA are used as open-drain output, the serial clock line and the serial data bus require a pull-up resistor.
- Wake-up mode: In the deep sleep mode, when the extension code or the local station address from the autonomous control device is received, the deep sleep mode can be released by generating an interrupt request signal (INTIICA). Set through the IICA control register

5.20 Analog-to-digital Converter (ADC)

This product has a built-in 12-bit resolution analog-to-digital converter SARADC, which can convert analog input to digital value and supports up to 35 channels of ADC analog input (ANI0~ANI24, ANI27~ANI36). The ADC contains the following functions:

- 12-bit resolution, conversion rate 500Ksps.
- Trigger mode: support software trigger, hardware trigger and hardware trigger in standby state
- Channel selection: support two modes of single-channel selection and multi-channel scanning
- Conversion mode: support single conversion and continuous conversion
- Working voltage: Support the working voltage range of $1.8V \leq V_{DD} \leq 5.5V$
- It can detect the built-in reference voltage (1.45V) and temperature sensor.

ADC can set various A/D conversion modes through the following mode combinations.

Trigger mode	Software trigger	Start the conversion by software operation.
	Hardware trigger no wait mode	Start the conversion by detecting the hardware trigger.
	Hardware trigger wait mode	In the conversion standby state with the power off, the power is turned on by detecting the hardware trigger, and the conversion starts automatically after the A/D power stabilization wait time.
Channel selection mode	Select mode	Select 1 channel of analog input for A/D conversion.
	Scan mode	Perform A/D conversion on 4 channels of analog input in sequence. It is possible to select 4 consecutive channels from ANI0 to ANI15 as analog input.
Conversion mode	Single conversion mode	Perform 1 A/D conversion on the selected channel.
	Continuous conversion mode	Perform continuous A/D conversion on the selected channel until it is stopped by software.
Sampling time/conversion time	Number of sampling clocks/number of conversion clocks	The sampling time can be set by the register. The default value of the sampling clock is 4 clk, and the Min value of the conversion clock is 16 clk.

5.21 Two-wire Serial Debug Port (SW-DP)

ARM's SW-DP interface allows to connect to the microcontroller through a serial wire debugging tool.

5.22 Security Function

5.22.1 Flash CRC Calculation Function (High-speed CRC, general-purpose CRC)

According to different purposes and conditions of use, the following 2 CRCs can be used respectively.

- High-speed CRC: In the initialization program, it can stop the operation of the CPU and check the entire code flash area at high speed.
- General CRC: In CPU operation, it is not limited to the code flash area but can be used for multi-purpose checking.

5.22.2 RAM Parity Error Detection Function

When reading RAM data, detect parity errors.

5.22.3 SFR Protection Function

Prevent the important SFR (Special Function Register) from being rewritten due to CPU runaway.

5.22.4 Illegal Memory Access Detection Function

Detect illegal access to illegal memory area (area without memory or area with restricted access).

5.22.5 Frequency Detection Function

Can use Timer4 unit to self-check CPU or peripheral hardware clock frequency.

5.22.6 A/D Test Function

The A/D converter is self-tested by performing A/D conversion on the A/D analog input channel (ANI), temperature sensor output voltage, and internal reference voltage.

5.22.7 Digital Output Signal Level Detection Function of Input/ Output Port

When the input/output port is in output mode, the output level of the pin can be read.

5.23 Key Function

The input pin (KR0~KR4) can be interrupted by the key to generate a key interrupt (INTKR).

6 Electrical Characteristics

6.1 Typical Application Peripheral Circuit

The device connection reference of the typical MCU application peripheral circuit is as follows:

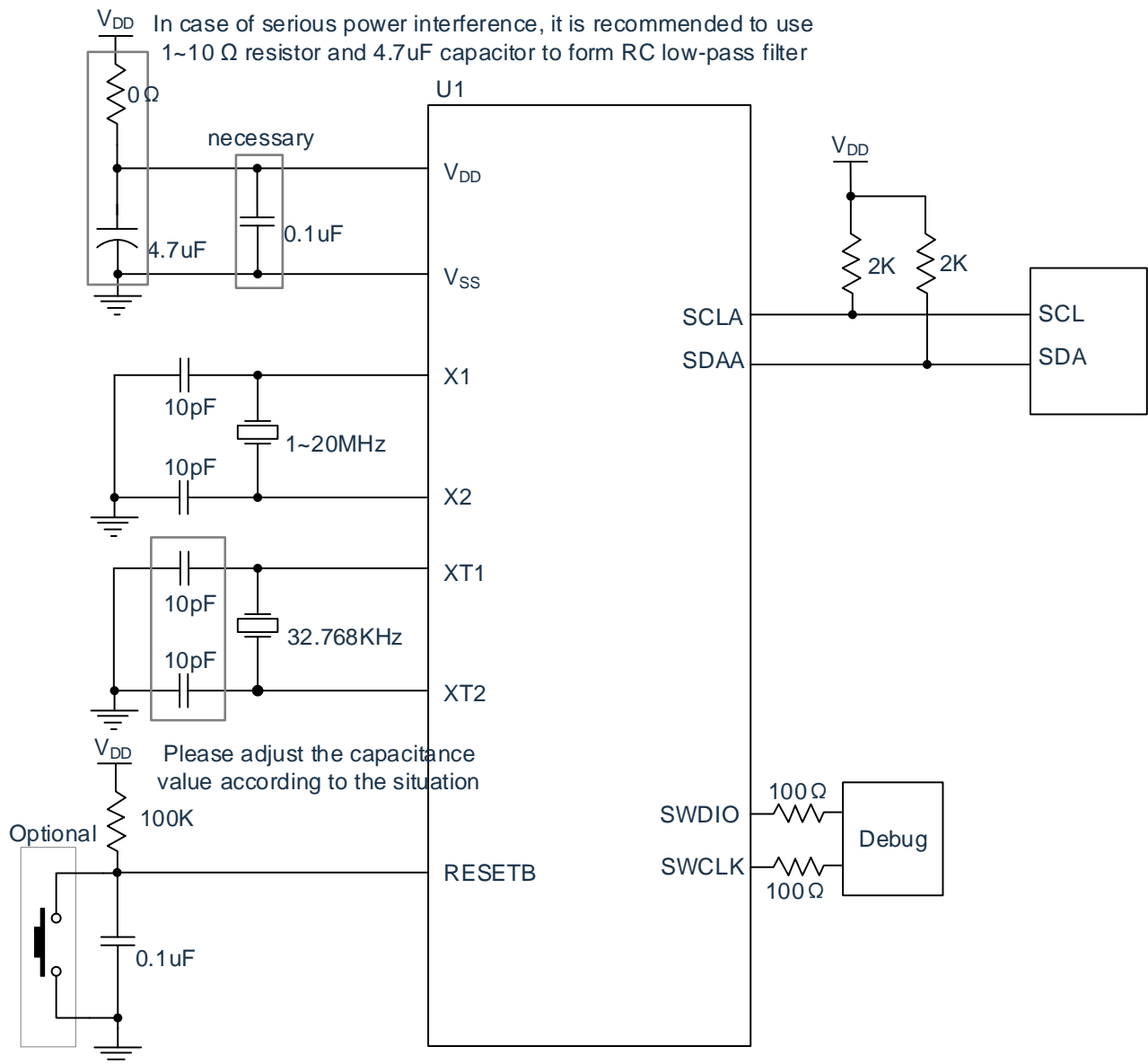

6.2 Absolute Maximum Voltage Rating

($T_A = -40 \sim 105^\circ\text{C}$)

Item	Symbol	Condition	Rating	Unit
Source voltage	V_{DD}	-	-0.5~+6.5	V
Input voltage	V_{I1}	P00~P01, P10~P17, P20~P27, P30~P31 P40~P41, P50~P51, P62~P63, P70~P75 P120~P124, P130, P136, P137, P140, P146 P147, EXCLK, EXCLKS, RESETB	-0.3~ $V_{DD}+0.3$ ^{Note1}	V
	V_{I2}	P60~P61 (N-channel open drain)	-0.3~+6.5	V
Output voltage	V_O	P00~P01, P10~P17, P20~P27, P30~P31 P40~P41, P50~P51, P60~P63, P70~P75, P120 P130, P136, P137, P140, P146, P147	-0.3~ $V_{DD}+0.3$ ^{Note1}	V
Analog input voltage	V_{AI}	ANI0~ANI24, ANI27~ANI36	-0.3~ $V_{DD}+0.3$ ^{Note1}	V

Note1: Do not exceed 6.5V.

Caution: Even if one of the items exceeds the absolute maximum rating for an instant, the quality of the product may be degraded. The absolute maximum rating is a rating that may cause physical damage to the product, and the product must be used under the condition that the rating is not exceeded.

Remarks:

1. Unless otherwise specified, the characteristics of multiplexed pins are the same as those of port pins.
2. Use V_{SS} as the reference voltage.

6.3 Absolute Maximum Current Rating

($T_A = -40 \sim 105^\circ\text{C}$)

Item	Symbol	Condition		Rating	Unit
High level output current	I _{OH1}	Each pin	P00~P01, P10~P17, P20~P27, P30~P31 P40~P41, P50~P51, P60~P63, P70~P75, P120 P130, P136, P137, P140, P146, P147	-15	mA
		Total pins -170mA	P00~P01, P20~P27, P40~P41, P120, P130 P136, P137, P140	-70	mA
			P10~P17, P30~P31, P50~P51, P60~P63 P70~P75, P146, P147	-100	mA
	I _{OH2}	Each pin	P121~P124	-3	mA
		Total pins		-15	mA
Low-level output current	I _{OL1}	Each pin	P00~P01, P10~P17, P20~P27, P30~P31 P40~P41, P50~P51, P60~P63, P70~P75, P120 P130, P136, P137, P140, P146, P147	40	mA
		Total pins 170mA	P00~P01, P20~P27, P40~P41, P120, P130 P136, P137, P140	100	mA
			P10~P17, P30~P31, P50~P51, P60~P63 P70~P75, P146, P147	120	mA
	I _{OL2}	Each pin	P121~P124	15	mA
		Total pins		45	mA
Working temperature	T _A	Normally run		-40~105	°C
		When flash programming			
Storage temperature	T _{stg}	-		-65~150	°C

Caution: Even if one of the items exceeds the absolute maximum rating for an instant, the quality of the product may be degraded. The absolute maximum rating is a rating that may cause physical damage to the product, and the product must be used under the condition that the rating is not exceeded.

Remark: Unless otherwise specified, the characteristics of multiplexed pins are the same as those of port pins.

6.4 Oscillation Circuit Characteristics

6.4.1 X1, XT1 Characteristics

($T_A = -40 \sim 105^\circ\text{C}$, $1.8\text{V} \leq V_{DD} \leq 5.5\text{V}$, $V_{SS} = 0\text{V}$)

Item	Resonator	Condition	Min	Typ	Max	Unit
X1 clock oscillation frequency (F_X)	Ceramic resonator/ crystal resonator	$1.8\text{V} \leq V_{DD} \leq 5.5\text{V}$	1.0	-	20.0	MHz
XT1 clock oscillation frequency (F_{XT})	Crystal resonator	$1.8\text{V} \leq V_{DD} \leq 5.5\text{V}$	32	32.768	35	KHz

Remark:

1. It only indicates the allowable frequency range of the oscillation circuit. Please refer to the AC characteristics for the command execution time.
2. Please entrust the resonator manufacturer to evaluate after installing the circuit, and use it after confirming the oscillation characteristics.

6.4.2 Internal Oscillator Characteristics

($T_A = -40 \sim 105^\circ\text{C}$, $1.8\text{V} \leq V_{DD} \leq 5.5\text{V}$, $V_{SS} = 0\text{V}$)

Resonator	Condition	Min	Typ	Max	Unit
High-speed internal oscillator clock frequency (F_{IH}) ^{Note1,2}	-	2.0	-	64.0	MHz
Clock frequency accuracy of high-speed internal oscillator	$T_A = 0 \sim 70^\circ\text{C}$	-1.0	-	+1.0	%
	$T_A = -40 \sim 105^\circ\text{C}$	-1.5 ^{Note3}	-	+1.5 ^{Note3}	%
Clock frequency of low-speed internal oscillator (F_{IL})	-	10	15	20	KHz

Note1: Select the frequency of the high-speed internal oscillator by the option byte.

Note2: It only shows the characteristics of the oscillation circuit, please refer to the AC characteristics for the command execution time.

Note3: Low temperature specification value is guaranteed by design, mass production does not measure low temperature condition.

6.5 DC Characteristics

6.5.1 Pin Characteristics

($T_A = -40 \sim 105^\circ\text{C}$, $1.8\text{V} \leq V_{DD} \leq 5.5\text{V}$, $V_{SS} = 0\text{V}$)

Item	Symbol	Condition	Min	Typ	Max	Unit		
high level output Current Note1		P00~P01, P10~P17, P20~P27 P30~P31, P40~P41, P50~P51 P60~P63, P70~P75, P120, P130 P136, P137, P140, P146, P147 1 pin alone	$1.8\text{V} \leq V_{DD} \leq 5.5\text{V}$ $-40 \sim 85^\circ\text{C}$	-	-	-12.0 ^{Note2}	mA	
			$1.8\text{V} \leq V_{DD} \leq 5.5\text{V}$ $85 \sim 105^\circ\text{C}$	-	-	-6.0 ^{Note2}		
	I _{OH1}	P00~P01, P20~P27, P40~P41 P120, P130, P136, P137, P140 Total pins (when duty cycle $\leq 70\%$ ^{Note3})	$4.0\text{V} \leq V_{DD} \leq 5.5\text{V}$ $-40 \sim 85^\circ\text{C}$	-	-	-60.0	mA	
			$4.0\text{V} \leq V_{DD} \leq 5.5\text{V}$ $85 \sim 105^\circ\text{C}$	-	-	-30.0		
			Total pins (when duty cycle $\leq 70\%$ ^{Note3})	$2.4\text{V} \leq V_{DD} < 4.0\text{V}$	-	-	-12.0	mA
				$1.8\text{V} \leq V_{DD} < 2.4\text{V}$	-	-	-6.0	mA
	I _{OH1}	P10~P17, P30~P31, P50~P51 P60~P63, P70~P75, P146, P147 Total pins (when duty cycle $\leq 70\%$ ^{Note3})	$4.0\text{V} \leq V_{DD} \leq 5.5\text{V}$ $-40 \sim 85^\circ\text{C}$	-	-	-80.0	mA	
			$4.0\text{V} \leq V_{DD} \leq 5.5\text{V}$ $85 \sim 105^\circ\text{C}$	-	-	-30.0		
			Total pins (when duty cycle $\leq 70\%$ ^{Note3})	$2.4\text{V} \leq V_{DD} < 4.0\text{V}$	-	-	-20.0	mA
				$1.8\text{V} \leq V_{DD} < 2.4\text{V}$	-	-	-10.0	mA
	I _{OH2}	P121 ~ P124 1 pin alone Total pins (when duty cycle $\leq 70\%$ ^{Note3})	$1.8\text{V} \leq V_{DD} \leq 5.5\text{V}$ $-40 \sim 85^\circ\text{C}$	-	-	-140.0	mA	
			$1.8\text{V} \leq V_{DD} \leq 5.5\text{V}$ $85 \sim 105^\circ\text{C}$	-	-	-60.0		
			P121 ~ P124 1 pin alone	$1.8\text{V} \leq V_{DD} \leq 5.5\text{V}$	-	-	-2.5 ^{Note2}	mA
			Total pins (when duty cycle $\leq 70\%$ ^{Note3})	$1.8\text{V} \leq V_{DD} \leq 5.5\text{V}$	-	-	-10	mA

Note1: This is the current value that guarantees the operation of the device even if current flows from the V_{DD} pin to the output pin.

Note2: Can not exceed the total current value.

Note3: This is the output current value of "duty cycle $\leq 70\%$ condition".

To change the output current value with a duty cycle $> 70\%$ can be calculated with the following calculation formula (when the duty cycle is changed to n%).

The total output current of the pins = $(I_{OH} \times 0.7) / (n \times 0.01)$

<example> $I_{OH} = -10.0\text{mA}$, $n = 80\%$

The total output current of the pins = $(-10.0 \times 0.7) / (80 \times 0.01) \approx -8.7\text{mA}$

The current of each pin does not change due to the duty cycle, and no current above the absolute maximum rating will flow.

Remark: Unless otherwise specified, the characteristics of multiplexed pins are the same as those of port pins.

$(T_A = -40 \sim 105^\circ\text{C}, 1.8\text{V} \leq V_{DD} \leq 5.5\text{V}, V_{SS} = 0\text{V})$

Item	Symbol	Condition	Min	Typ	Max	Unit		
Low-level output current ^{Note 1}		P00~P01, P10~P17, P20~P27 P30~P31, P40~P41, P50~P51 P60~P63, P70~P75, P120, P130 P136, P137, P140, P146, P147 1 pin alone	$1.8\text{V} \leq V_{DD} \leq 5.5\text{V}$ $-40 \sim 85^\circ\text{C}$	-	-	35 ^{Note2}	mA	
			$1.8\text{V} \leq V_{DD} \leq 5.5\text{V}$ $85 \sim 105^\circ\text{C}$	-	-	20 ^{Note2}		
	I_{OL1}	P00~P01, P20~P27, P40~P41, P120 P130, P136, P137, P140 Total pins (when duty cycle $\leq 70\%$ ^{Note3})	$4.0\text{V} \leq V_{DD} \leq 5.5\text{V}$ $-40 \sim 85^\circ\text{C}$	-	-	100	mA	
			$4.0\text{V} \leq V_{DD} \leq 5.5\text{V}$ $85 \sim 105^\circ\text{C}$	-	-	70		
			$2.4\text{V} \leq V_{DD} < 4.0\text{V}$	-	-	30	mA	
			$1.8\text{V} \leq V_{DD} < 2.4\text{V}$	-	-	15	mA	
		P10~P17, P30~P31, P50~P51 P60~P63, P70~P75, P146, P147 Total pins (when duty cycle $\leq 70\%$ ^{Note3})	$4.0\text{V} \leq V_{DD} \leq 5.5\text{V}$ $-40 \sim 85^\circ\text{C}$	-	-	120	mA	
			$4.0\text{V} \leq V_{DD} \leq 5.5\text{V}$ $85 \sim 105^\circ\text{C}$	-	-	80		
			$2.4\text{V} \leq V_{DD} < 4.0\text{V}$	-	-	40	mA	
			$1.8\text{V} \leq V_{DD} < 2.4\text{V}$	-	-	20	mA	
		Total pins (when duty cycle $\leq 70\%$ ^{Note3})	$1.8\text{V} \leq V_{DD} \leq 5.5\text{V}$ $-40 \sim 85^\circ\text{C}$	-	-	150	mA	
			$1.8\text{V} \leq V_{DD} \leq 5.5\text{V}$ $85 \sim 105^\circ\text{C}$	-	-	100		
		I_{OL2}	P121 ~ P124 1 pin alone	$1.8\text{V} \leq V_{DD} \leq 5.5\text{V}$	-	-	10 ^{Note2}	mA
			Total pins (when duty cycle $\leq 70\%$ ^{Note3})	$1.8\text{V} \leq V_{DD} \leq 5.5\text{V}$	-	-	40	mA

Note1: This is the current value that guarantees the operation of the device even if the current flows from the output pin to the V_{SS} pin.

Note2: Can not exceed the total current value.

Note3: This is the output current value of "duty cycle $\leq 70\%$ condition".

The output current value with a duty cycle $> 70\%$ can be calculated with the following calculation formula (when the duty cycle is changed to $n\%$)

The total output current of the pins = $(I_{OL} \times 0.7) / (n \times 0.01)$

<example> $I_{OL} = 10.0\text{mA}$, $n = 80\%$

The total output current of the pins = $(10.0 \times 0.7) / (80 \times 0.01) \approx 8.7\text{mA}$

The current of each pin does not change due to the duty cycle, and no current above the absolute maximum rating will flow.

Remark: Unless otherwise specified, the characteristics of multiplexed pins are the same as those of port pins.

($T_A = -40 \sim 105^\circ\text{C}$, $1.8\text{V} \leq V_{DD} \leq 5.5\text{V}$, $V_{SS} = 0\text{V}$)

Item	Symbol	Condition	Min	Typ	Max	Unit
High level input voltage	V_{IH1}	P00~P01, P10~P17, P20~P27 P30~P31, P40~P41, P50~P51 P62~P63, P70~P75, P120~P124 EXCLK, EXCLKS, RESETB, P130 P136, P137, P140, P146, P147	Schmidt input 0.8 V_{DD}	-	V_{DD}	V
	V_{IH2}	P60~P61	0.7 V_{DD}	-	6.0	V
High level input voltage	V_{IL1}	P00~P01, P10~P17, P20~P27 P30~P31, P40~P41, P50~P51 P62~P63, P70~P75, P120~P124 EXCLK, EXCLKS, RESETB, P130 P136, P137, P140, P146, P147	Schmidt input 0	-	0.2 V_{DD}	V
	V_{IL2}	P60~P61	0	-	0.3 V_{DD}	V

Remark: Unless otherwise specified, the characteristics of multiplexed pins are the same as those of port pins.

(T_A= -40~105°C, 1.8V≤V_{DD}≤5.5V, V_{SS}=0V)

Item	Symbol	Condition	Min	Typ	Max	Unit	
High level output voltage	V _{OH1}	P00~P01, P10~P17, P20~P27 P30~P31, P40~P41, P50~P51 P60~P63, P70~P75, P120, P130 P136, P137, P140, P146, P147	4.0V≤V _{DD} ≤5.5V I _{OH1} =-12.0mA	V _{DD} -1.5	-	-	V
			4.0V≤V _{DD} ≤5.5V I _{OH1} =-6.0mA	V _{DD} -0.7	-	-	V
			2.4V≤V _{DD} ≤5.5V I _{OH1} =-3.0mA	V _{DD} -0.6	-	-	V
			1.8V≤V _{DD} ≤5.5V I _{OH1} =-2mA	V _{DD} -0.5	-	-	V
	V _{OH2}	P121~P124	4.0V≤V _{DD} ≤5.5V I _{OH2} =-2.5mA	V _{DD} -1.5	-	-	V
			4.0V≤V _{DD} ≤5.5V I _{OH2} =-1.5mA	V _{DD} -0.7	-	-	V
			2.4V≤V _{DD} ≤5.5V I _{OH2} =-0.5mA	V _{DD} -0.6	-	-	V
			1.8V≤V _{DD} ≤5.5V I _{OH2} =-0.4mA	V _{DD} -0.5	-	-	V
Low-level output voltage	V _{OL1}	P00~P01, P10~P17, P20~P27 P30~P31, P40~P41, P50~P51 P60~P63, P70~P75, P120, P130 P136, P137, P140, P146, P147	4.0V≤V _{DD} ≤5.5V I _{OL1} =35.0mA	-	-	1.2	V
			4.0V≤V _{DD} ≤5.5V I _{OL1} =20.0mA	-	-	0.7	V
			2.4V≤V _{DD} ≤5.5V I _{OL1} =9.0mA	-	-	0.4	V
			1.8V≤V _{DD} ≤5.5V I _{OL1} =6.0mA	-	-	0.4	V
	V _{OL2}	P121~P124	4.0V≤V _{DD} ≤5.5V I _{OL2} =10.0mA	-	-	1.2	V
			4.0V≤V _{DD} ≤5.5V I _{OL2} =6.0mA	-	-	0.7	V
			2.4V≤V _{DD} ≤5.5V I _{OL2} =2.5mA	-	-	0.4	V
			1.8V≤V _{DD} ≤5.5V I _{OL2} =1.5mA	-	-	0.4	V

Remark: Unless otherwise specified, the characteristics of multiplexed pins are the same as those of port pins.

(T_A= -40~105°C, 1.8V ≤ V_{DD} ≤ 5.5V, V_{SS}=0V)

Item	Symbol	Condition	Min	Typ	Max	Unit	
High-level input leakage current	I _{LIH1}	P00~P01, P10~P17, P20~P27 P30~P31, P40~P41, P50~P51 P60~P63, P70~P75, P120, P130 P136, P137, P140, P146, P147	V _I =V _{DD}	-	-	1	uA
	I _{LIH2}	RESETB	V _I =V _{DD}	-	-	1	uA
	I _{LIH3}	P121~P124 (X1, X2, EXCLK, XT1 XT2, EXCLKS)	V _I =V _{DD} , when input port and external clock input	-	-	1	uA
			V _I =V _{DD} , when the resonator is connected	-	-	10	uA
Low-level input leakage current	I _{LIL1}	P00~P01, P10~P17, P20~P27 P30~P31, P40~P41, P50~P51 P60~P63, P70~P75, P120, P130 P136, P137, P140, P146, P147	V _I =V _{SS}	-	-	-1	uA
	I _{LIL2}	RESETB	V _I =V _{SS}	-	-	-1	uA
	I _{LIL3}	P121~P124 (X1, X2, EXCLK, XT1 XT2, EXCLKS)	V _I =V _{SS} , when input port and external clock input	-	-	-1	uA
			V _I =V _{SS} , when the resonator is connected	-	-	-10	uA
Internal pull-up resistor	R _U	P00~P01, P10~P17, P20~P27 P30~P31, P40~P41, P50~P51 P60~P63, P70~P75, P120, P130 P136, P137, P140, P146, P147	V _I =V _{SS} , when input port	10	30	100	kΩ
Internal pull-down resistor	R _D	P00~P01, P10~P17, P20~P27 P30~P31, P50~P51, P60~P63 P70~P75, P120, P130, P136, P137 P140, P146, P147	V _I =V _{DD} , when input port	10	30	100	kΩ

Remark: Unless otherwise specified, the characteristics of multiplexed pins are the same as those of port pins.

6.5.2 Power Supply Current Characteristics

($T_A = -40 \sim 105^\circ\text{C}$, $1.8\text{V} \leq V_{DD} \leq 5.5\text{V}$, $V_{SS} = 0\text{V}$)

Item	Symbol	Condition		Min	Typ	Max	Unit			
Current ^{Note1}	I _{DD1}	Operating mode	High-speed internal oscillator	F _{HOCO} =64MHz, F _{IH} =64MHz ^{Note3}	-	4.5	6.9	mA		
				F _{HOCO} =64MHz, F _{IH} =32MHz ^{Note3}	-	3.5	4.5			
			High-speed main system clock	F _{MX} =20MHz ^{Note2}	Input square wave	-	6.0	6.5	mA	
					Connect the crystal	-	6.0	6.5		
			Subsystem clock operation	F _{SUB} =32.768KHz ^{Note4}	Input square wave	-	175	300	uA	
					Connect the crystal	-	175	300		
			Low-speed internal oscillator	F _{IL} =15KHz ^{Note8}	-	174	300	uA		
			I _{DD2}	Sleep mode	High-speed internal oscillator	F _{HOCO} =64MHz, F _{IH} =64MHz ^{Note3}	-	1.7	2.6	mA
						F _{HOCO} =32MHz, F _{IH} =32MHz ^{Note3}	-	1.1	1.7	
					High-speed main system clock	F _{MX} =20MHz ^{Note2}	Input square wave	-	0.85	1.3
	Connecting crystal	-					0.85	1.3		
	Subsystem clock operation	F _{SUB} =32.768KHz ^{Note5}			Input square wave	-	85	240	uA	
			Connecting crystal	-	85	240				
Low-speed internal oscillator	F _{IL} =15KHz ^{Note8}	-	85	240	uA					
I _{DD3} ^{Note6}	Deep sleep mode ^{Note7}	-		-	80	185	uA			

Note1: This is the current flowing through V_{DD}, including the input leakage current when the input pin is fixed to V_{DD} or V_{SS}. Typ. Value: CPU is in the execution of multiplication instruction (I_{DD1}), And does not include peripheral operating current. Max. Value: CPU is in full instruction execution action (I_{DD1}), and includes peripheral operating current, but does not include the flow to the A/D converter. The current of the LVD circuit, I/O port, and internal pull-up or pull-down resistors does not include the current when rewriting data flash memory

Note2: This is the case when the high-speed internal oscillator and the subsystem clock stop oscillating.

Note3: This is the case where the high-speed main system clock and subsystem clock stop oscillating.

Note4: This is the case when the high-speed internal oscillator and the high-speed main system clock stop oscillating.

Note5: This is the case when the high-speed internal oscillator and the high-speed main system clock

stop oscillating. Contains the current flowing to the RTC, but does not include the 15-bit interval timer and watchdog Timer current.

Note6: Does not include current to RTC, 15-bit interval timer and watchdog timer.

Note7: For the current value when the subsystem clock is running in the deep sleep mode, please refer to the current value when the subsystem clock is running in the sleep mode.

Note8: This is the case where the high-speed internal oscillator, the high-speed main system clock and the subsystem clock stop oscillating.

Remark:

1. F_{HOCO} : The clock frequency of the high-speed internal oscillator
 F_{IH} : the system clock frequency provided by the high-speed internal oscillator.
2. F_{SUB} : External subsystem clock frequency (XT1/XT2 clock oscillation frequency).
3. F_{MX} : External main system clock frequency (X1/X2 clock oscillation frequency).
4. F_{IL} : Clock frequency of low-speed internal oscillator.
5. Typ. The temperature condition of the value is $T_A=25^{\circ}\text{C}$.

($T_A = -40 \sim 105^\circ\text{C}$, $1.8\text{V} \leq V_{DD} \leq 5.5\text{V}$, $V_{SS} = 0\text{V}$)

Parameter	Symbol	Condition	Min	Typ	Max	Unit
Low-speed internal oscillator operating current	I_{FIL}^{Note1}	-	-	0.2	-	uA
RTC operating current	$I_{RTC}^{\text{Note1,2,3}}$	-	-	0.04	-	uA
15-bit interval timer operating current	$I_{IT}^{\text{Note1,2,4}}$	-	-	0.02	-	uA
Watchdog timer operating current	$I_{WDT}^{\text{Note1,2,5}}$	$F_{IL} = 15\text{KHz}$	-	0.22	-	uA
A/D converter operating current	$I_{ADC}^{\text{Note1,6}}$	ADC @8MHz	-	2.2	-	mA
LVD operating current	$I_{LVD}^{\text{Note1,7}}$	-	-	0.08	-	uA

Note1: This is the current flowing through V_{DD} .

Note2: This is the case when the high-speed internal oscillator and the high-speed system clock stop oscillating.

Note3: This is the current that only flows to the real-time clock (RTC) (not including the operating current of the low-speed internal oscillator and XT1 oscillator circuit). When the real-time clock is running in running mode or sleep mode, the current value of the microcontroller is I_{DD1} or I_{DD2} plus the value of I_{RTC} . In addition, when low-speed internal oscillator is selected, I_{FIL} must be added. I_{DD2} when the subsystem clock is running contains the operating current of the real-time clock.

Note4: This is the current that only flows to the 15-bit interval timer (not including the operating current of the low-speed internal oscillator and XT1 oscillator circuit). When the 15-bit interval timer is running in run mode or sleep mode, the current value of the microcontroller is the value of I_{DD1} or I_{DD2} plus I_{IT} . In addition, when low-speed internal oscillator is selected, I_{FIL} must be added.

Note5: This is the current that only flows to the watchdog timer (including the operating current of the low-speed internal oscillator). When the watchdog timer is running, the current value of the microcontroller is I_{DD1} or I_{DD2} or I_{DD3} plus the value of I_{WDT} .

Note6: This is the current that only flows to the A/D converter. When the A/D converter is running in running mode or sleep mode, the current value of the microcontroller is I_{DD1} or I_{DD2} plus the value of I_{ADC} .

Note7: This is the current that only flows to the LVD circuit. In the case of LVD circuit operation, the current value of the microcontroller is the value of I_{DD1} or I_{DD2} or I_{DD3} plus I_{LVD} .

Remark:

1. F_{IL} : Clock frequency of low-speed internal oscillator.
2. Typ. The temperature condition of the value is $T_A = 25^\circ\text{C}$.

6.6 AC Characteristic

($T_A = -40 \sim 105^\circ\text{C}$, $1.8\text{V} \leq V_{DD} \leq 5.5\text{V}$, $V_{SS} = 0\text{V}$)

Item	Symbol	Condition		Min	Typ	Max	Unit
Instruction cycle (Minimum instruction execution time)	T_{CY}	The main system clock (F_{MAIN}) runs	$1.8\text{V} \leq V_{DD} \leq 5.5\text{V}$	0.015625	-	0.5	us
		Subsystem clock (F_{SUB}) operation	$1.8\text{V} \leq V_{DD} \leq 5.5\text{V}$	28.5	30.5	31.3	us
External system clock frequency	F_{EX}	$1.8\text{V} \leq V_{DD} \leq 5.5\text{V}$		1.0	-	20.0	MHz
	F_{EXS}	$1.8\text{V} \leq V_{DD} \leq 5.5\text{V}$		32.0	-	35.0	KHz
High and low level width of external system clock input	T_{EXH} T_{EXL}	$1.8\text{V} \leq V_{DD} \leq 5.5\text{V}$		24	-	-	ns
	T_{EXHS} T_{EXLS}	$1.8\text{V} \leq V_{DD} \leq 5.5\text{V}$		13.7	-	-	us
Ti00 ~ Ti03, Ti10 ~ Ti13, input high and low level width	T_{TIH} T_{TIL}	$1.8\text{V} \leq V_{DD} \leq 5.5\text{V}$		$1/F_{MCK} + 10$	-	-	ns
TO00 ~ TO03 TO10 ~ TO13 output frequency	F_{TO}	$4.0\text{V} \leq V_{DD} \leq 5.5\text{V}$		-	-	16	MHz
		$2.4\text{V} \leq V_{DD} < 4.0\text{V}$		-	-	8	MHz
		$1.8\text{V} \leq V_{DD} < 2.4\text{V}$		-	-	4	MHz
CLKBUZ0, CLKBUZ1 Output frequency	F_{PCL}	$4.0\text{V} \leq V_{DD} \leq 5.5\text{V}$		-	-	16	MHz
		$2.4\text{V} \leq V_{DD} < 4.0\text{V}$		-	-	8	MHz
		$1.8\text{V} \leq V_{DD} < 2.4\text{V}$		-	-	4	MHz
Interrupt input high and low level width	T_{INTH} T_{INTL}	INTP0 ~ INTP3	$1.8\text{V} \leq V_{DD} \leq 5.5\text{V}$	1	-	-	us
Key interrupt input high and low level width	T_{KR}	KR0 ~ KR5	$1.8\text{V} \leq V_{DD} \leq 5.5\text{V}$	250	-	-	ns
RESETB low-level width	T_{RSL}	-		10	-	-	-

Remark: F_{MCK} : Operating clock frequency of timer4 unit.

6.7 Peripheral Features

6.7.1 Universal Interface Unit

1) UART mode

($T_A = -40 \sim 85^\circ\text{C}$, $1.8\text{V} \leq V_{DD} \leq 5.5\text{V}$, $V_{SS} = 0\text{V}$)

Item	Condition		Specification Value		Unit
			Min	Max	
Transfer rate	$1.8\text{V} \leq V_{DD} \leq 5.5\text{V}$	-	-	$F_{MCK}/6$	bps
		The theoretical value of the maximum transfer rate $F_{MCK} = F_{CLK}$	-	10.6	Mbps

($T_A = -40 \sim 85^\circ\text{C}$, $1.8\text{V} \leq V_{DD} \leq 5.5\text{V}$, $V_{SS} = 0\text{V}$)

Item	Condition		Specification Value		Unit
			Min	Max	
Transfer rate	$1.8\text{V} \leq V_{DD} \leq 5.5\text{V}$	-	-	$F_{MCK}/12$	bps
		Theoretical value of the maximum transfer rate $F_{MCK} = F_{CLK}$	-	5.3	Mbps

2) Three-wire SPI mode (master mode, internal clock output)

 $(T_A = -40 \sim 105^\circ\text{C}, 1.8\text{V} \leq V_{DD} \leq 5.5\text{V}, V_{SS} = 0\text{V})$

Item	Symbol	Condition	-40~85°C		85~105°C		Unit	
			Min	Max	Min	Max		
SCLKp cycle time	T_{KCY1}	$T_{KCY1} \geq 2/f_{CLK}$	$4.0\text{V} \leq V_{DD} \leq 5.5\text{V}$	31.25	-	62.5	-	ns
			$2.7\text{V} \leq V_{DD} \leq 5.5\text{V}$	41.67	-	83.33	-	
			$2.4\text{V} \leq V_{DD} \leq 5.5\text{V}$	65	-	125	-	ns
			$1.8\text{V} \leq V_{DD} \leq 5.5\text{V}$	125	-	250	-	ns
SCLKp high/low level width	$T_{KH1},$ T_{KL1}	$4.0\text{V} \leq V_{DD} \leq 5.5\text{V}$	$T_{KCY1}/2-4$	-	$T_{KCY1}/2-7$	-	ns	
		$2.7\text{V} \leq V_{DD} \leq 5.5\text{V}$	$T_{KCY1}/2-5$	-	$T_{KCY1}/2-10$	-	ns	
		$2.4\text{V} \leq V_{DD} \leq 5.5\text{V}$	$T_{KCY1}/2-10$	-	$T_{KCY1}/2-20$	-	ns	
		$1.8\text{V} \leq V_{DD} \leq 5.5\text{V}$	$T_{KCY1}/2-19$	-	$T_{KCY1}/2-38$	-	ns	
SDIp preparatio n time (to SCLKp↑)	T_{SIK1}	$4.0\text{V} \leq V_{DD} \leq 5.5\text{V}$	12	-	23	-	ns	
		$2.7\text{V} \leq V_{DD} \leq 5.5\text{V}$	17	-	33	-	ns	
		$2.4\text{V} \leq V_{DD} \leq 5.5\text{V}$	20	-	38	-	ns	
		$1.8\text{V} \leq V_{DD} \leq 5.5\text{V}$	28	-	55	-	ns	
SDIp hold time (to SCLKp↑)	T_{KSI1}	$1.8\text{V} \leq V_{DD} \leq 5.5\text{V}$	5	-	10	-	ns	
SCLKp↓→ SDOp output delay time	T_{KSO1}	$1.8\text{V} \leq V_{DD} \leq 5.5\text{V}$ $C=20\text{pF}$ <small>Note1</small>	-	5	-	10	ns	

Note1: C is the load capacitance of the SCLKp and SDOp output lines.

Caution: Through the port inputmode register and the port outputmode register, the SDOp pin is selected as the normal input buffer and the SDOp the pin and SCLKp pin are selected as the usual output mode.

Remark: Guaranteed by design, not tested in production.

3) Three-wire SPI mode (slave mode, external clock input)

 $(T_A = -40 \sim 105^\circ\text{C}, 1.8\text{V} \leq V_{DD} \leq 5.5\text{V}, V_{SS} = 0\text{V})$

Item	Symbol	Condition	-40 ~ 85°C		85 ~ 105°C		Unit	
			Min	Max	Min	Max		
SCLKp cycle time	T_{KCY2}	$4.0\text{V} \leq V_{DD} \leq 5.5\text{V}$	$20\text{MHz} < F_{MCK}$	$8 / F_{MCK}$	-	$16 / F_{MCK}$	-	ns
			$F_{MCK} \leq 20\text{MHz}$	$6 / F_{MCK}$	-	$12 / F_{MCK}$	-	ns
		$2.7\text{V} \leq V_{DD} \leq 5.5\text{V}$	$16\text{MHz} < F_{MCK}$	$8 / F_{MCK}$	-	$16 / F_{MCK}$	-	ns
			$F_{MCK} \leq 16\text{MHz}$	$6 / F_{MCK}$	-	$12 / F_{MCK}$	-	ns
		$2.4\text{V} \leq V_{DD} \leq 5.5\text{V}$		$6 / F_{MCK}$ and ≥ 500	-	$12 / F_{MCK}$ and ≥ 1000	-	ns
		$1.8\text{V} \leq V_{DD} \leq 5.5\text{V}$		$6 / F_{MCK}$ and ≥ 750	-	$12 / F_{MCK}$ and ≥ 1500	-	ns
SCLKp high/low level width	T_{KH2} T_{KL2}	$4.0\text{V} \leq V_{DD} \leq 5.5\text{V}$		$T_{KCY1}/2-7$	-	$T_{KCY1}/2-14$	-	ns
		$2.7\text{V} \leq V_{DD} \leq 5.5\text{V}$		$T_{KCY1}/2-8$	-	$T_{KCY1}/2-16$	-	ns
		$1.8\text{V} \leq V_{DD} \leq 5.5\text{V}$		$T_{KCY1}/2-18$	-	$T_{KCY1}/2-36$	-	ns
SDIp preparation time (to SCLKp↑)	T_{SIK2}	$2.7\text{V} \leq V_{DD} \leq 5.5\text{V}$		$1 / F_{MCK} + 20$	-	$1 / F_{MCK} + 40$	-	ns
		$1.8\text{V} \leq V_{DD} \leq 5.5\text{V}$		$1 / F_{MCK} + 30$	-	$1 / F_{MCK} + 60$	-	ns
SDIp hold time (to SCLKp↑)	T_{KSI2}	$1.8\text{V} \leq V_{DD} \leq 5.5\text{V}$		$1 / F_{MCK} + 31$	-	$1 / F_{MCK} + 62$	-	ns
SCLKp↓→S DOp output delay time	T_{KSO2}	$2.7\text{V} \leq V_{DD} \leq 5.5\text{V}$ $C=30\text{pF}$ ^{Note1}		-	$2 / F_{MCK} + 44$	-	$2 / F_{MCK} + 66$	ns
		$2.4\text{V} \leq V_{DD} \leq 5.5\text{V}$ $C=30\text{pF}$ ^{Note1}		-	$2 / F_{MCK} + 75$	-	$2 / F_{MCK} + 113$	ns
		$1.8\text{V} \leq V_{DD} \leq 5.5\text{V}$ $C=30\text{pF}$ ^{Note1}		-	$2 / F_{MCK} + 100$	-	$2 / F_{MCK} + 150$	ns

Note1: C is the load capacitance of the SCLKp and SDOp output lines.

Caution: Through the port inputmode register and the port outputmode register, select the SDIp pin and SCLKp pin as the normal input buffer and select the SDOp pin as the normal output mode.

Remark: Guaranteed by design, not tested in production.

4) Four-wire SPI mode (slave mode, external clock input)

 ($T_A = -40 \sim 105^\circ\text{C}$, $1.8\text{V} \leq V_{DD} \leq 5.5\text{V}$, $V_{SS} = 0\text{V}$)

Item	Symbol	Condition	-40~85°C		85~105°C		unit	
			Min	Max	Min	Max		
SSI00 set up time	T_{SSIK}	DAPmn=0	$2.7\text{V} \leq V_{DD} \leq 5.5\text{V}$	120	-	240	-	ns
			$1.8\text{V} \leq V_{DD} \leq 5.5\text{V}$	200	-	400	-	ns
		DAPmn=1	$2.7\text{V} \leq V_{DD} \leq 5.5\text{V}$	$1/F_{MCK}+120$	-	$1/F_{MCK}+240$	-	ns
			$1.8\text{V} \leq V_{DD} \leq 5.5\text{V}$	$1/F_{MCK}+200$	-	$1/F_{MCK}+400$	-	ns
SSI00 hold time	T_{KSSI}	DAPmn=0	$2.7\text{V} \leq V_{DD} \leq 5.5\text{V}$	$1/F_{MCK}+120$	-	$1/F_{MCK}+240$	-	ns
			$1.8\text{V} \leq V_{DD} \leq 5.5\text{V}$	$1/F_{MCK}+200$	-	$1/F_{MCK}+400$	-	ns
		DAPmn=1	$2.7\text{V} \leq V_{DD} \leq 5.5\text{V}$	120	-	240	-	ns
			$1.8\text{V} \leq V_{DD} \leq 5.5\text{V}$	200	-	400	-	ns

Caution: Through the port inputmode register and the port outputmode register, select the SDIp pin and SCLKp pin as the normal input buffer and select the SDOp pin as the normal outputmode.

Remark: Guaranteed by design, not tested in production.

5) Simple IIC mode

 $(T_A = -40 \sim 105^\circ\text{C}, 1.8\text{V} \leq V_{DD} \leq 5.5\text{V}, V_{SS} = 0\text{V})$

Item	Symbol	Condition	-40~85°C		85~105°C		Unit
			Min	Max	Min	Max	
SCLr Clock frequency	F _{SCL}	2.7V ≤ V _{DD} ≤ 5.5V C _b = 50 pF, R _b = 2.7 kΩ	-	1000 ^{Note1}	-	400 ^{Note1}	KHz
		1.8V ≤ V _{DD} ≤ 5.5V C _b = 100 pF, R _b = 3 kΩ	-	400 ^{Note1}	-	100 ^{Note1}	KHz
		1.8V ≤ V _{DD} ≤ 2.7V C _b = 100 pF, R _b = 5 kΩ	-	300 ^{Note1}	-	75 ^{Note1}	KHz
Hold time when SCLr is low	T _{LOW}	2.7V ≤ V _{DD} ≤ 5.5V C _b = 50 pF, R _b = 2.7 kΩ	475	-	1200	-	ns
		1.8V ≤ V _{DD} ≤ 5.5V C _b = 100 pF, R _b = 3 kΩ	1150	-	4600	-	ns
		1.8V ≤ V _{DD} ≤ 2.7V C _b = 100 pF, R _b = 5 kΩ	1550	-	6500	-	ns
Hold time when SCLr is high	T _{HIGH}	2.7V ≤ V _{DD} ≤ 5.5V C _b = 50 pF, R _b = 2.7 kΩ	475	-	1200	-	ns
		1.8V ≤ V _{DD} ≤ 5.5V C _b = 100 pF, R _b = 3 kΩ	1150	-	4600	-	ns
		1.8V ≤ V _{DD} ≤ 2.7V C _b = 100 pF, R _b = 5 kΩ	1550	-	6500	-	ns
Data establishment time (received)	T _{SU: DAT}	2.7V ≤ V _{DD} ≤ 5.5V C _b = 50 pF, R _b = 2.7 kΩ	1/F _{MCK} + 85 ^{Note2}	-	1/F _{MCK} + 220 ^{Note2}	-	ns
		1.8V ≤ V _{DD} ≤ 5.5V C _b = 100 pF, R _b = 3 kΩ	1/F _{MCK} + 145 ^{Note2}	-	1/F _{MCK} + 580 ^{Note2}	-	ns
		1.8V ≤ V _{DD} ≤ 2.7V C _b = 100 pF, R _b = 5 kΩ	1/F _{MCK} + 230 ^{Note2}	-	1/F _{MCK} + 1200 ^{Note2}	-	ns
Data retention time (send)	T _{HD: DAT}	2.7V ≤ V _{DD} ≤ 5.5V C _b = 50 pF, R _b = 2.7 kΩ	-	305	-	770	ns
		1.8V ≤ V _{DD} ≤ 5.5V C _b = 100 pF, R _b = 3 kΩ	-	355	-	1420	ns
		1.8V ≤ V _{DD} ≤ 2.7V C _b = 100 pF, R _b = 5 kΩ	-	405	-	2070	ns

 Note1: Must be set to at least F_{MCK}/4.

 Note2: The set value of F_{MCK} cannot exceed the holding time of SCLr="L" and SCLr="H".

6.7.2 Serial Interface IICA

1) I²C standard mode

($T_A = -40 \sim 105^\circ\text{C}$, $1.8\text{V} \leq V_{DD} \leq 5.5\text{V}$, $V_{SS} = 0\text{V}$)

Item	Symbol	Condition	Specification Value		Unit
			Min	Max	
SCLA0 clock frequency	F_{SCL}	Standard mode: $F_{CLK} \geq 1\text{MHz}$	-	100	KHz
Start condition set up time	$T_{SU: STA}$	-	4.7	-	us
Start condition hold time ^{Note1}	$T_{HD: STA}$	-	4.0	-	us
Hold time when SCLA0 is low	T_{LOW}	-	4.7	-	us
Hold time when SCLA0 is high	T_{HIGH}	-	4.0	-	us
Data establishment time (received)	$T_{SU: DAT}$	-	250	-	ns
Data retention time (send) ^{Note2}	$T_{HD: DAT}$	-	0	3.45	us
Stop condition set up time	$T_{SU: STO}$	-	4.0	-	us
Bus idle time	T_{BUF}	-	4.7	-	us

Note1: Generate the first clock pulse after generating the start condition or restarting the condition.

Note2: During normal transmission, t_{HD} : the maximum value of DAT (Max.) needs to be guaranteed, and it is necessary to wait for an acknowledgement (ACK).

Remark: The Max. value of C_b (communication line capacitance) of each mode and the value of R_b (communication line pull-up resistance value) at this time are as follows:

Standard mode: $C_b = 400\text{pF}$, $R_b = 2.7\text{k}\Omega$

2) I²C fast mode

($T_A = -40 \sim 105^\circ\text{C}$, $1.8\text{V} \leq V_{DD} \leq 5.5\text{V}$, $V_{SS} = 0\text{V}$)

Item	Symbol	Condition	Specification Value		Unit
			Min	Max	
SCLA0 clock frequency	F_{SCL}	Fast mode: $F_{CLK} \geq 3.5\text{MHz}$	-	400	KHz
Start condition set up time	$T_{SU: STA}$	-	0.6	-	us
Start condition hold time ^{Note1}	$T_{HD: STA}$	-	0.6	-	us
Hold when SCLA0 is low time	T_{LOW}	-	1.3	-	us
Hold when SCLA0 is high time	T_{HIGH}	-	0.6	-	us
Data set up time (received)	$T_{SU: DAT}$	-	100	-	ns
Data hold time (send) ^{Note2}	$T_{HD: DAT}$	-	0	0.9	us
Stop condition set up time	$T_{SU: STO}$	-	0.6	-	us
Bus idle time	T_{BUF}	-	1.3	-	us

Note1: Generate the first clock pulse after generating the start condition or restarting the condition.

Note2: During normal transmission, t_{HD} : the maximum value of DAT (Max.) needs to be guaranteed, and it is necessary to wait for an acknowledgement (ACK).

Remark: The Max. value of C_b (communication line capacitance) of each mode and the value of R_b (communication line pull-up resistance value) at this time are as follows:

Fast mode: $C_b = 320\text{pF}$, $R_b = 1.1\text{k}\Omega$

3) I²C enhanced fast mode

 (T_A= -40~105°C, 1.8V ≤ V_{DD} ≤ 5.5V, V_{SS}=0V)

Item	Symbol	Condition	Specification Value		Unit
			Min	Max	
SCLA0 clock frequency	F _{SCL}	Enhanced fast mode: F _{CLK} ≥ 10MHz	-	1000	KHz
Start condition set up time	T _{SU: STA}	-	0.26	-	us
Start condition hold time ^{Note1}	T _{HD: STA}	-	0.26	-	us
Hold time when SCLA0 is low	T _{LOW}	-	0.5	-	us
When SCLA0 is high hold time	T _{HIGH}	-	0.26	-	us
Data set up time (received)	T _{SU: DAT}	-	50	-	ns
Data hold time (send) ^{Note2}	T _{HD: DAT}	-	0	0.45	us
Stop condition set up time	T _{SU: STO}	-	0.26	-	us
Bus idle time	T _{BUF}	-	0.5	-	us

Note1: Generate the first clock pulse after generating the start condition or restarting the condition.

Note2: During normal transmission, t_{HD}: the maximum value of DAT (Max.) needs to be guaranteed, and it is necessary to wait for an acknowledgement (ACK).

Remark: The Max.value of C_b (communication line capacitance) of each mode and the value of R_b (communication line pull-up resistance value) at this time are as follows:

Enhanced fast mode: C_b=120pF, R_b=1.1KΩ

6.8 Analog Characteristic

6.8.1 A/D Converter Characteristic

The distinction of A/D converter characteristic

Input channel	Reference voltage	Reference voltage (+) = V_{DD} Reference voltage (-) = V_{SS}
ANI0~ANI36		Refer to the table below
Internal reference voltage, output voltage of temperature sensor		

Select the case of reference voltage(+) = V_{DD} , reference voltage(-) = V_{SS}

($T_A = -40 \sim 105^\circ\text{C}$, $1.8\text{V} \leq V_{DD} \leq 5.5\text{V}$, $V_{SS} = 0\text{V}$, reference voltage(+) = V_{DD} , reference voltage(-) = V_{SS})

Item	Symbol	Condition		Min	Typ	Max	Unit
Resolution	RES	-		-	12	-	bit
Composite error Note1	AINL	12-bit resolution	$1.8\text{V} \leq V_{DD} \leq 5.5\text{V}$	-	6	-	LSB
Conversion time Note3	T_{CONV}	12-bit resolution Conversion target: ANI0~ANI36	$1.8\text{V} \leq V_{DD} \leq 5.5\text{V}$	16	-	-	Tmclk
Zero error Note1	E_{ZS}	12-bit resolution	$1.8\text{V} \leq V_{DD} \leq 5.5\text{V}$	-	0	-	LSB
Full scale error Note1	E_{FS}	12-bit resolution	$1.8\text{V} \leq V_{DD} \leq 5.5\text{V}$	-	0	-	LSB
Integral linearity error Note1	ILE	12-bit resolution	$1.8\text{V} \leq V_{DD} \leq 5.5\text{V}$	-	-	± 2	LSB
Differential linearity error Note1	DLE	12-bit resolution	$1.8\text{V} \leq V_{DD} \leq 5.5\text{V}$	-	-	± 3	LSB
Analog input voltage	V_{AIN}	ANI0~ANI36		0	-	V_{DD}	V
		Internal reference voltage ($1.8\text{V} \leq V_{DD} \leq 5.5\text{V}$)		V_{BGR} Note2			V
		The output voltage of the temperature sensor ($1.8\text{V} \leq V_{DD} \leq 5.5\text{V}$)		V_{TMPS25} Note2			V

Note1: Does not include quantization error ($\pm 1/2$ LSB).

Note2: "6.8.2 Characteristic of Temperature Sensor/Internal Reference Voltage"

Note3: Tmclk is the AD action clock cycle, the maximum action frequency is 8MHz.

Remark: Guaranteed by design, not tested in production.

6.8.2 Characteristic of Temperature Sensor/Internal Reference Voltage

($T_A = -40 \sim 105^\circ\text{C}$, $1.8\text{V} \leq V_{DD} \leq 5.5\text{V}$, $V_{SS} = 0\text{V}$)

Item	Symbol	Condition	Min	Typ	Max	Unit
The output voltage of the temperature sensor	$V_{T\text{MPS}25}$	$T_A = 25^\circ\text{C}$	-	1.09	-	V
Internal reference voltage	V_{BGR}	-	1.38 ^{Note1}	1.45	1.5 ^{Note1}	V
Temperature Coefficient	$F_{V\text{T\text{MPS}}}$	-	-	-3.5	-	$\text{mV}/^\circ\text{C}$
Stable operation waiting time	T_{AMP}	-	5	-	-	us

Note1: Low temperature Specification Value is guaranteed by design, mass production does not measure low temperature conditions.

6.8.3 POR Circuit Characteristic

($T_A = -40 \sim 105^\circ\text{C}$, $V_{SS} = 0\text{V}$)

Item	Symbol	Condition	Min	Typ	Max	Unit
Detection voltage	V_{POR}	When the power supply voltage rises	-	1.50	1.75	V
	V_{PDR}	When the power supply voltage drops	1.37	1.45	-	V
Minimum pulse width ^{Note1}	T_{PW}	-	300	-	-	us

Note1: This is the time required for POR to reset when V_{DD} is lower than V_{PDR} . In addition, in the deep sleep mode, when the main system clock (F_{MAIN}) is stopped by setting bit0 (HIOSTOP) and bit7 (MSTOP) of the clock operation status control register (CSC), the oscillation of the main system clock (F_{MAIN}) is stopped from V_{DD} lower than 0.7V to rise above V_{POR} . Time required for POR reset.

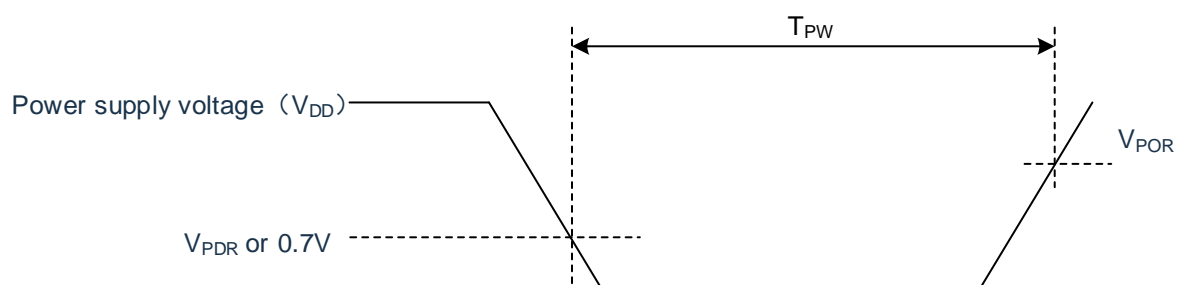

6.8.4 LVD Circuit Characteristic

1) Reset mode, interrupt mode

($T_A = -40 \sim 105^\circ\text{C}$, $V_{PDR} \leq V_{DD} \leq 5.5\text{V}$, $V_{SS} = 0\text{V}$)

Item	Symbol	Condition	Min	Typ	Max	Unit
Detection voltage	V_{LVD0}	power supply voltage rises	-	4.06	4.14	V
		power supply voltage drops	3.90	3.98	-	V
	V_{LVD1}	power supply voltage rises	-	3.75	-	V
		power supply voltage drops	-	3.67	-	V
	V_{LVD2}	power supply voltage rises	-	3.13	-	V
		power supply voltage drops	-	3.06	-	V
	V_{LVD3}	power supply voltage rises	-	3.02	-	V
		power supply voltage drops	-	2.96	-	V
	V_{LVD4}	power supply voltage rises	-	2.92	-	V
		power supply voltage drops	-	2.86	-	V
	V_{LVD5}	power supply voltage rises	-	2.81	-	V
		power supply voltage drops	-	2.75	-	V
	V_{LVD6}	power supply voltage rises	-	2.71	-	V
		power supply voltage drops	-	2.65	-	V
	V_{LVD7}	power supply voltage rises	-	2.61	-	V
		power supply voltage drops	-	2.55	-	V
	V_{LVD8}	power supply voltage rises	-	2.50	-	V
		power supply voltage drops	-	2.45	-	V
	V_{LVD9}	power supply voltage rises	-	2.09	-	V
		power supply voltage drops	-	2.04	-	V
	V_{LVD10}	power supply voltage rises	-	1.98	-	V
		power supply voltage drops	-	1.94	-	V
V_{LVD11}	power supply voltage rises	-	1.88	1.91	V	
	power supply voltage drops	1.80	1.84	-	V	
Minimum pulse width	T_{LW}	-	300	-	-	us
Detection delay	-	-	-	-	300	us

2) Interrupt & reset mode

 $(T_A = -40 \sim 105^\circ\text{C}, V_{PDR} \leq V_{DD} \leq 5.5\text{V}, V_{SS} = 0\text{V})$

Item	Symbol	Condition		Min	Typ	Max	Unit	
Interrupt & reset mode	VLVDA0	$V_{POC2}, V_{POC1}, V_{POC0}=0, 0, 0$, Falling reset voltage		1.60	1.63	-	V	
	VLVDA1		LVIS1, LVIS0=1, 0	rising reset release voltage	-	1.77	1.81	V
				drop interrupt voltage	1.70	1.73	-	V
	VLVDA2		LVIS1, LVIS0=0, 1	rising reset release voltage	-	1.88	-	V
				drop interrupt voltage	-	1.84	-	V
	VLVDA3		LVIS1, LVIS0=0, 0	rising reset release voltage	-	2.92	-	V
				drop interrupt voltage	-	2.86	-	V
	VLVDB0	$V_{POC2}, V_{POC1}, V_{POC0}=0, 0, 1$, decrease reset voltage		-	1.84	-	V	
	VLVDB1		LVIS1, LVIS0=1, 0	rising reset release voltage	-	1.98	-	V
				drop interrupt voltage	-	1.94	-	V
	VLVDB2		LVIS1, LVIS0=0, 1	rising reset release voltage	-	2.09	-	V
				drop interrupt voltage	-	2.04	-	V
	VLVDB3		LVIS1, LVIS0=0, 0	rising reset release voltage	-	3.13	-	V
				drop interrupt voltage	-	3.06	-	V
	VLVDC0	$V_{POC2}, V_{POC1}, V_{POC0}=0, 1, 0$, decrease reset voltage		-	2.45	-	V	
	VLVDC1		LVIS1, LVIS0=1, 0	rising reset release voltage	-	2.61	-	V
				drop interrupt voltage	-	2.55	-	V
	VLVDC2		LVIS1, LVIS0=0, 1	rising reset release voltage	-	2.71	-	V
				drop interrupt voltage	-	2.65	-	V
	VLVDC3		LVIS1, LVIS0=0, 0	rising reset release voltage	-	3.75	-	V
				drop interrupt voltage	-	3.67	-	V
	VLVDD0	$V_{POC2}, V_{POC1}, V_{POC0}=0, 1, 1$, decrease reset voltage		-	2.75	-	V	
	VLVDD1		LVIS1, LVIS0=1, 0	rising reset release voltage	-	2.92	-	V
				drop interrupt voltage	-	2.86	-	V
VLVDD2		LVIS1, LVIS0=0, 1	rising reset release voltage	-	3.02	-	V	
			drop interrupt voltage	-	2.96	-	V	
VLVDD3		LVIS1, LVIS0=0, 0	rising reset release voltage	-	4.06	4.14	V	
			drop interrupt voltage	3.90	3.98	-	V	

6.8.5 Reset Time and Rising Slope of The Power Supply Voltage

($T_A = -40 \sim 105^\circ\text{C}$, $V_{SS} = 0\text{V}$)

Item	Symbol	Condition	Min	Typ	Max	Unit
Reset time	T_{RESET}	-	-	1	-	ms
The rising slope of the power supply voltage	S_{VDD}	-	-	-	54	V/ms

6.9 Memory Characteristic

6.9.1 Flash Memory

($T_A = -40 \sim 105^\circ\text{C}$, $1.8\text{V} \leq V_{DD} \leq 5.5\text{V}$, $V_{SS} = 0\text{V}$)

Symbol	Parameter	Conditions	Min	Max	Unit
T_{PROG}	Word Program (32bit)	$T_A = -40 \sim 105^\circ\text{C}$	-	120	us
T_{ERASE}	Sector erase	$T_A = -40 \sim 105^\circ\text{C}$	2	3	ms
	Chip erase	$T_A = -40 \sim 105^\circ\text{C}$	30	40	ms
N_{END}	Endurance	$T_A = -40 \sim 105^\circ\text{C}$	100	-	Kcycle
T_{RET}	Data retention	100 kcycle ^{Note1} at $T_A = 105^\circ\text{C}$	20	-	Years

Note1: Guaranteed by design, not tested in production.

Remark: Cycling performed over the whole temperature range.

6.9.2 RAM Memory

($T_A = -40 \sim 105^\circ\text{C}$, $1.8\text{V} \leq V_{DD} \leq 5.5\text{V}$, $V_{SS} = 0\text{V}$)

Symbol	Parameter	Conditions	Min	Max	Unit
V_{RAMHOLD}	RAM Hold Voltage	$T_A = -40 \sim 105^\circ\text{C}$	0.8	-	V

6.10 EMS

6.10.1 Electrostatic Discharge (ESD)

Symbol	Parameter	Conditions	Class
$V_{ESD1(HBM)}^{Note1}$	Electrostatic discharge voltage (human body model)	$T_A = 25^\circ\text{C}$ conforming to JESD22-A114	3A
$V_{ESD2(HBM)}^{Note2}$	Electrostatic discharge voltage (human body model)	$T_A = 25^\circ\text{C}$ conforming to JESD22-A114	1A

Note1: HBM performance of IO pins except RESETB, P60 and P61.

Note2: HBM performance of RESETB, P60 and P61 IO.

Remark 1: Guaranteed by design, not tested in production.

6.10.2 Static Latch-up(LU)

Symbol	Parameter	Conditions	Class
LU	Static latch-up class	$T_A = 25^\circ\text{C}$ conforming to JESD78E	I LevelA

Remark: Guaranteed by design, not tested in production.

7 Package Information

7.1 TSSOP20 (6.5x4.4mm, 0.65mm spacing)

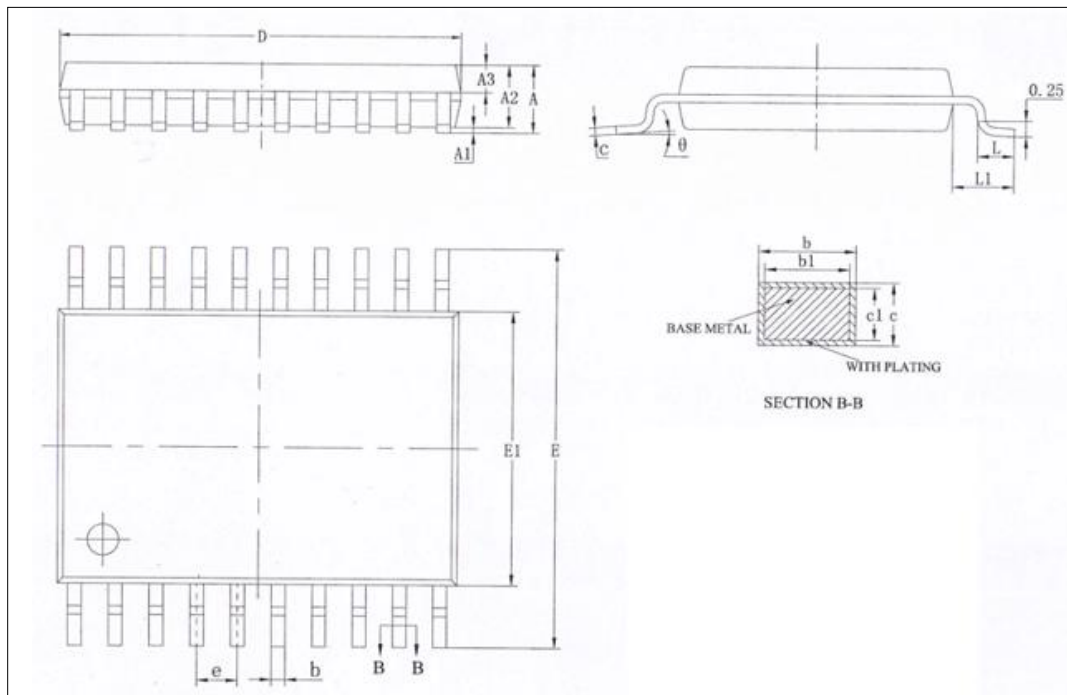

Symbol	Millimeter		
	Min	Nom	Max
A	-	-	1.20
A1	0.05	-	0.15
A2	0.80	1.00	1.05
A3	0.39	0.44	0.49
b	0.20	-	0.28
b1	0.19	0.22	0.25
c	0.13	-	0.17
c1	0.12	0.13	0.14
D	6.40	6.50	6.60
E1	4.30	4.40	4.50
E	6.20	6.40	6.60
e	0.65BSC		
L	0.45	0.60	0.75
L1	1.00REF		
θ	0	-	8°

7.2 QFN20 (3x3mm, 0.4mm spacing)

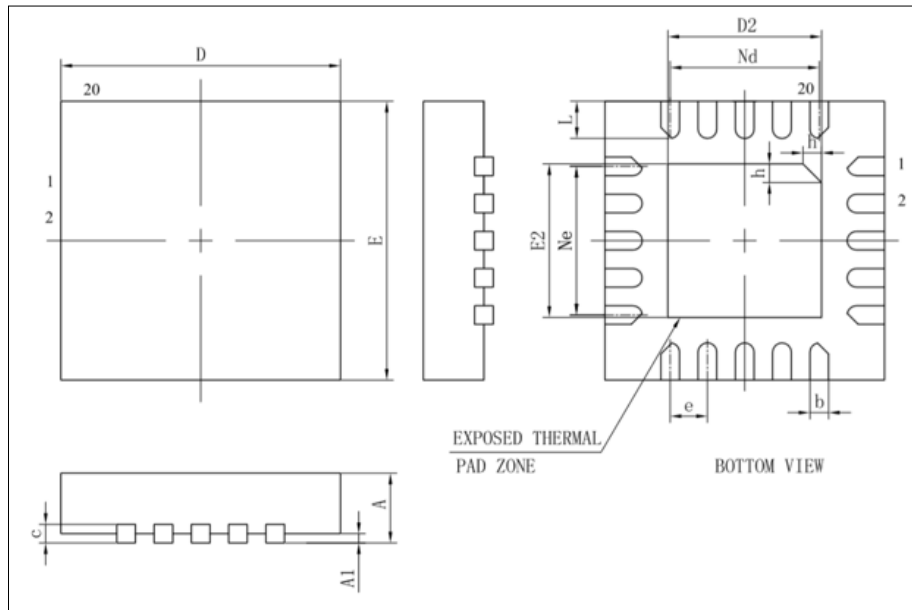

Symbol	Millimeter		
	Min	Nom	Max
A	0.70	0.75	0.80
A1	-	0.02	0.05
b	0.15	0.20	0.25
c	0.18	0.20	0.25
D	2.90	3.00	3.10
D2	1.55	1.65	1.75
e	0.40BSC		
Ne	1.60BSC		
Nd	1.60BSC		
E	2.90	3.00	3.10
E2	1.55	1.65	1.75
L	0.35	0.40	0.45
h	0.20	0.25	0.30

7.3 SSOP24 (8.65x3.9mm, 0.635mm spacing)

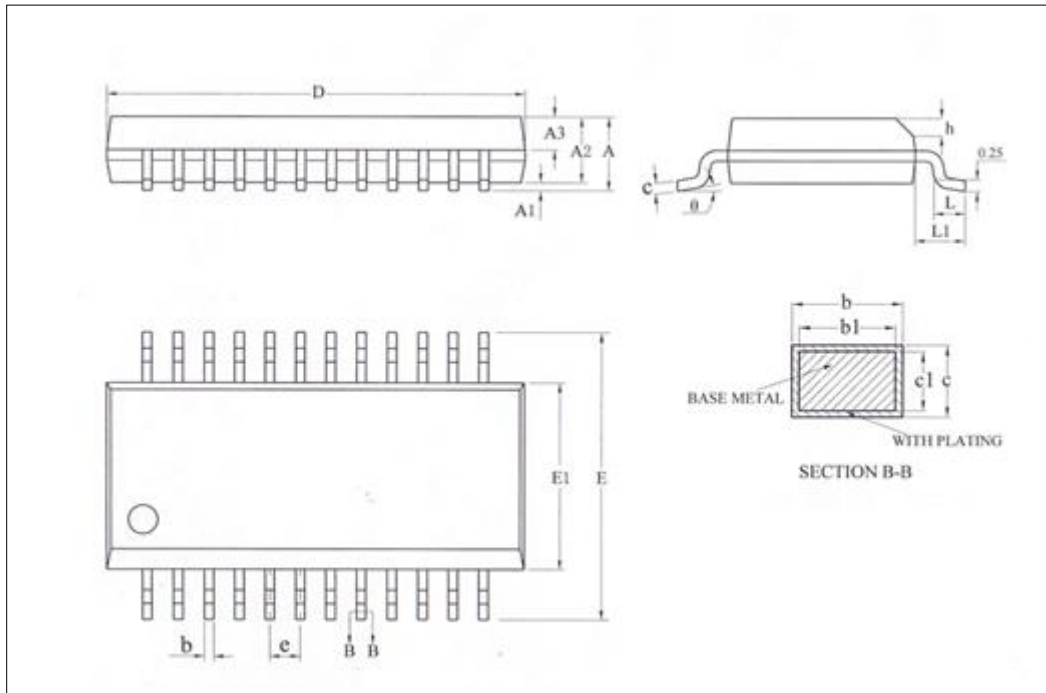

Symbol	Millimeter		
	Min	Nom	Max
A	-	-	1.75
A1	0.10	0.15	0.25
A2	1.30	1.40	1.50
A3	0.60	0.65	0.70
b	0.23	-	0.31
b1	0.22	0.25	0.28
c	0.20	-	0.24
c1	0.19	0.20	0.21
D	8.55	8.65	8.75
E1	3.80	3.90	4.00
E	5.80	6.00	6.20
e	0.635BSC		
h	0.30	-	0.50
L	0.50	-	0.80
L1	1.05REF		
θ	0	-	8°

7.4 QFN24 (4x4mm, 0.5mm spacing)

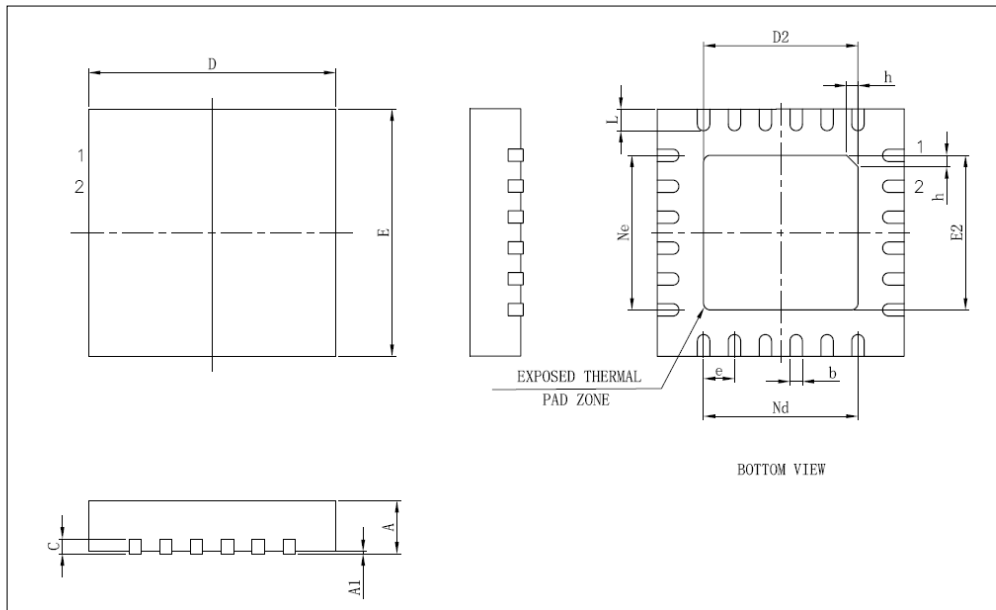

Symbol	Millimeter		
	Min	Nom	Max
A	0.70	0.75	0.80
A1	-	0.02	0.05
b	0.18	0.25	0.30
c	0.18	0.20	0.25
D	3.90	4.00	4.10
D2	2.40	2.50	2.60
e	0.50BSC		
Ne	2.50BSC		
Nd	2.50BSC		
E	3.90	4.00	4.10
E2	2.40	2.50	2.60
L	0.35	0.40	0.45
h	0.30	0.35	0.40

7.5 LQFP32 (7x7mm,0.8mm spacing)

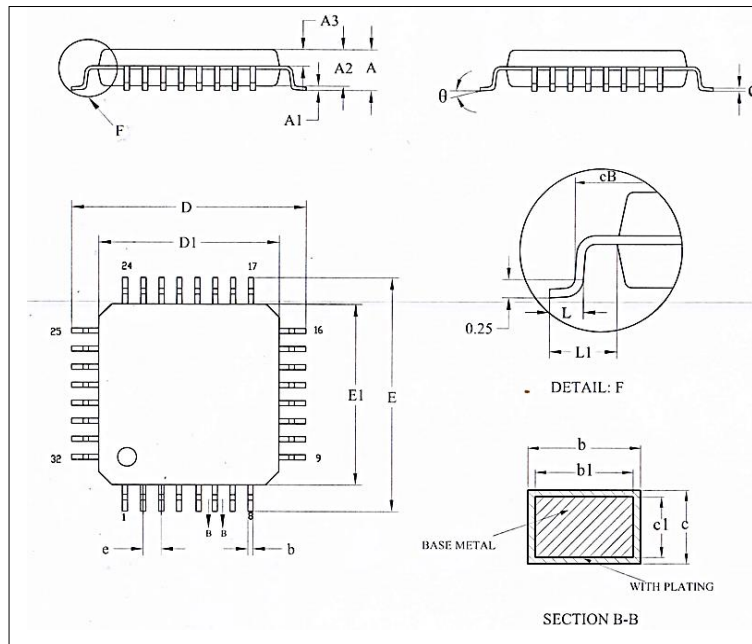

Symbol	Millimeter		
	Min	Nom	Max
A	-	-	1.60
A1	0.05	-	0.15
A2	1.35	1.40	1.45
A3	0.59	0.64	0.69
b	0.33	-	0.41
b1	0.32	0.35	0.38
c	0.13	-	0.17
c1	0.12	0.13	0.14
D	8.80	9.00	9.20
D1	6.90	7.00	7.10
E	8.80	9.00	9.20
E1	6.90	7.00	7.10
eB	8.10	-	8.25
e	0.80BSC		
L	0.45	-	0.75
L1	1.00REF		
θ	0°	-	7°

7.6 QFN32 (5x5mm, 0.5mm spacing)

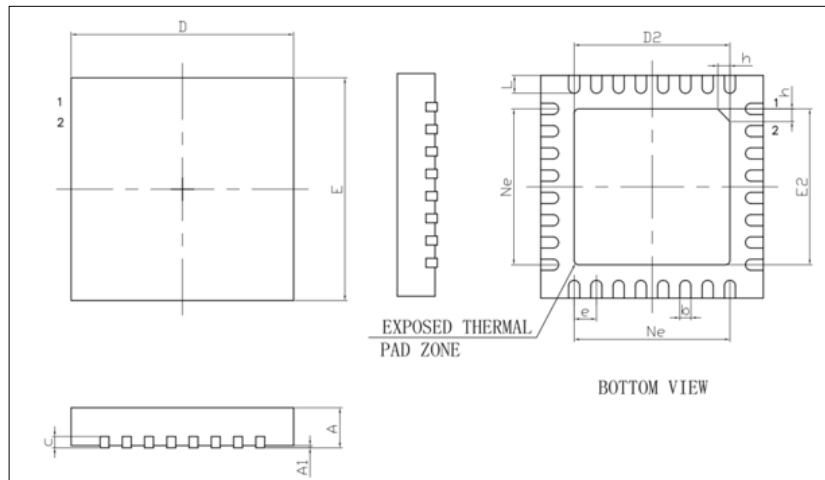

Symbol	Millimeter		
	Min	Nom	Max
A	0.70	0.75	0.80
A1	-	0.02	0.05
b	0.18	0.25	0.30
c	0.18	0.20	0.25
D	4.90	5.00	5.10
D2	3.40	3.50	3.60
e	0.50BSC		
Ne	3.50BSC		
E	4.90	5.00	5.10
E2	3.40	3.50	3.60
L	0.35	0.40	0.45
h	0.30	0.35	0.40

7.7 QFN40 (5x5mm,0.4mm spacing)

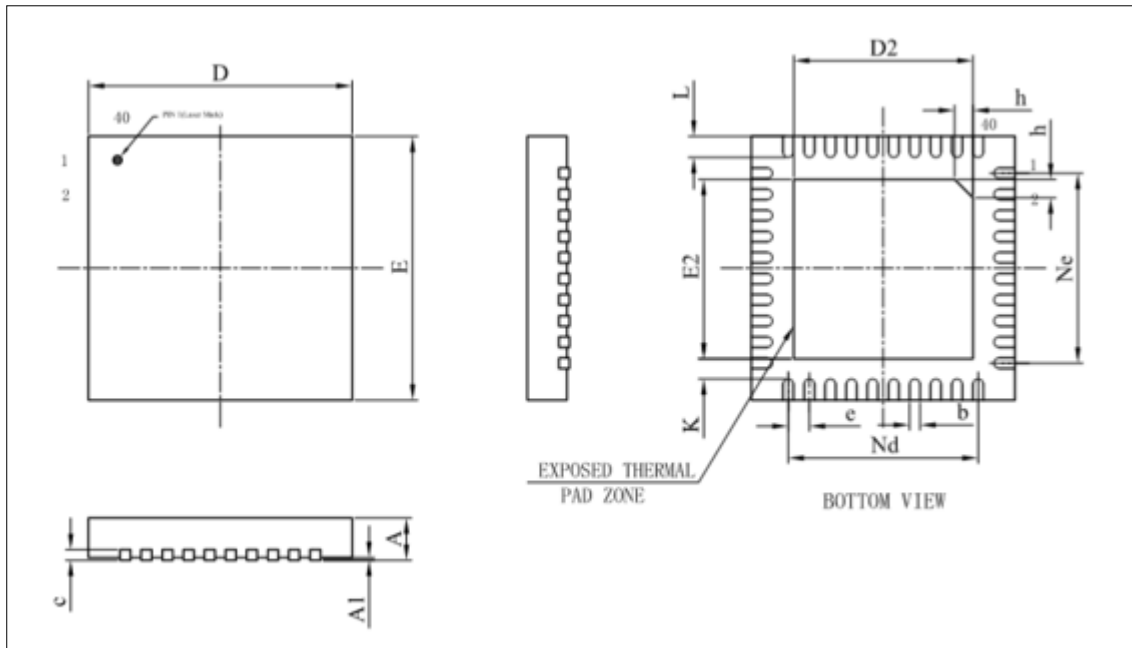

Symbol	Millimeter		
	Min	Nom	Max
A	0.70	0.75	0.80
A1	-	0.02	0.05
b	0.15	0.20	0.25
c	0.18	0.20	0.25
D	4.90	5.00	5.10
D2	3.30	3.40	3.50
e	0.40BSC		
Nd	3.60BSC		
E	4.90	5.00	5.10
E2	3.30	3.40	3.50
Ne	3.60BSC		
L	0.35	0.40	0.45
K	0.20	-	-
h	0.30	0.35	0.40

7.8 LQFP48 (7x7mm,0.5mm spacing)

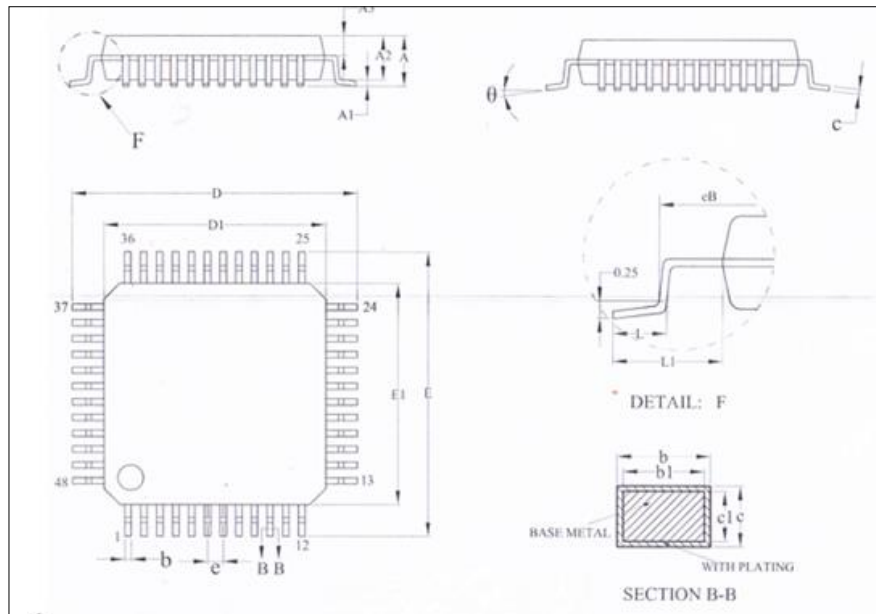

Symbol	Millimeter		
	Min	Nom	Max
A	-	-	1.60
A1	0.05	-	0.15
A2	1.35	1.40	1.45
A3	0.59	0.64	0.69
b	0.18	-	0.26
b1	0.17	0.20	0.23
c	0.13	-	0.17
c1	0.12	0.13	0.14
D	8.80	9.00	9.20
D1	6.90	7.00	7.10
E	8.80	9.00	9.20
E1	6.90	7.00	7.10
eB	8.10	-	8.25
e	0.50BSC		
L	0.45	-	0.75
L1	1.00REF		
θ	0	-	7°

8 Revision History

Revision	Date	Modify content
V1.00	May 2021	Original Issue
V1.10	Aug 2021	6.5.2: misrepresentation
V1.20	Sep 2021	1.3, 7.1, 7.2, 7.3: add package types
V1.30	Oct 2021	1.3, 7.1, 7.2, 7.3: add package types
V1.40	Nov 2021	1.3, 7.1, 7.2, 7.3: add package types
V1.50	Dec 2021	6.5.2: modify power current
V1.60	Mar 2022	1.3.2, 7.2: add package type
V1.70	Jun 2022	4.1, 4.3: add port function and type 5.7, 5.8: add Note for Low power consumption mode
V1.80	Aug 2022	1.3, 7: adjust pin diagram format
V1.90	Oct 2022	All chapter: niform format Change 6.3 Absolute maximum current rating and 6.4.2 Internal oscillator characteristics and standardize the format of electrical parameters
V1.9.1	Dec 2022	In 6.5.2, modify the maximum value of clock running current of the subsystem; Modify partial power-off deep sleep mode current Corrected pin connection figure 1.3.4 In 6.10.1, add ESD electrical characteristics description In 6.4.2, Modify the temperature characteristics of the internal oscillator
V1.9.2	Mar 2023	In 6.6, Correct parameters Table 4.1.3: Corrections
V1.9.3	Apr 2023	Correct the encapsulation information in 7.3
V1.9.4	Jun 2023	Delete the content and instructions related to the "deep sleep mode with partial power down".
V1.9.5	Apr 2024	1) Added some notes to the pin diagram in section 1.3.6/1.3.7 2) Modified section 6.1 Typical Application Peripheral Circuit 3) Corrected the cover page