



# BAT32G133 Datasheet

**Value-line Arm®-based 32-bit MCU with up to 32KB Flash,**

**Analog functions, Timers and Communication interfaces.**

**V1.5.2**

Please note the following CMS IP policy

\*Zhongwei Semiconductor (Shenzhen) Co., Ltd. (hereinafter referred to as the Company) has applied for a patent and enjoys absolute legal rights and interests. The patent rights related to the Company's MCUs or other products have not been authorized to be licensed, and any company, organization or individual who infringes the Company's patent rights through improper means will take all possible legal actions to curb the infringer's improper infringement and recover the losses suffered by the Company as a result of the infringement or the illegal benefits obtained by the infringer.

\*The name and logo of Zhongwei Semiconductor (Shenzhen) Co., Ltd. are registered trademarks of the Company.

\*The Company reserves the right to further explain the reliability, functionality and design improvements of the products in the data sheet. However, the Company is not responsible for the use of the Specification Contents. The applications mentioned herein are for illustrative purposes only and the Company does not warrant and does not represent that these applications can be applied without further modification, nor does it recommend that its products be used in places that may cause harm to persons due to malfunction or other reasons. The Company's products are not licensed for lifesaving, life-sustaining devices or systems as critical devices. The Company reserves the right to modify the product without prior notice, please refer to the official website [www.mcu.com.cn](http://www.mcu.com.cn) for the latest information

## Features

- **Ultra-low power consumption technology**
  - Operating Voltage:2.0V~5.5V
  - Operating ambient temperature: -40°C ~105°C
  - Low power modes: sleep, deep sleep
  - Operating power consumption:
    - RUN mode: 35uA/MHz@64MHz
    - Deep sleep mode:0.45uA
    - Deep sleep mode+32.768K+RTC:0.7uA
- **Core**
  - ARM®32-bit Cortex®-M0+ CPU
  - Operating frequency:32KHz~64MHz
- **Memories**
  - 32KB Flash Memory: program/data flash
  - 1.5KB Special data flash memory
  - 4KB SRAM Memory (With Parity)
- **Reset and power management**
  - Power-on reset circuit.
  - On-chip voltage detector (LVD) (Select interrupt and reset from 10 levels)
- **Clock**
  - Main clock oscillator: 1MHz to 20MHz
  - Sub clock oscillator: 32.768KHz
  - High-speed on-chip oscillator: 2MHz to 64MHz
  - Low-speed on-chip oscillator: 15KHz/30KHz
- **Multiplier/divider**
  - Integer 32bit multiplier
- **DMA**
  - Interrupt trigger start.
  - Transfer modes: Normal mode, Repeat mode, Block mode and Chain transfers mode
  - transmission field of source/destination address space for the whole range of optional
- **Analog**
  - 12-Bit A/D Converter, conversion rate 1.42Msps, 15 external analog channels, with temperature sensor, supporting single-channel conversion mode and multi-channel scan conversion mode. Conversion range: 0 to positive reference voltage
  - Comparator (CMP) × 2: The external reference voltage or internal reference voltage can be selected as the reference voltage
  - Programmable gain amplifier (PGA)×2: GAIN x4/8/10/12/14/16/32 can be selected
- **GPIO**
  - I/O port:13 to 22
  - Can be set to N-ch open drain and on-chip pull-up resistor
  - Digital function can be freely assigned to any pin
  - On-chip clock output/buzzer output controller
- **Serial wire debug (SWD)**
- **Timers**
  - 16-bit timer: 8 channels
  - 15-bit interval timer: 1 channel
  - Real-time clock (RTC): 1 channel
  - Watchdog timer (WWDT): 1 channel (operable with the dedicated low-speed on-chip oscillator)
  - SysTick timer
- **Serial interfaces**
  - SPI: 6 channels
  - UART:3 channels
  - I<sup>2</sup>C:1 channel
  - IrDA:1 channel

- **EVENTC**

- Event Link Controller
- Event signals (15 types) can be used as activation sources for operating any one of 3 types of peripheral functions

- **Safety**

- IEC/UL 60730
- Illegal memory access
- SRAM Parity Error Check
- Cyclic Redundancy Check (CRC) Calculator
- SFR protection
- 128-bit unique ID
- Flash secondary protection in debug mode (Level 1: Flash can only be erased in all fields, not read and write; Level 2: the simulator connection is invalid, and Flash operation is not allowed)

- **Packages**

- QFN24, QFN20, SSOP24, TSSOP20

# 1 Overview

## 1.1 Introduction

The ultra-low-power BAT32G133 incorporates a high-performance ARM®Cortex®-M0+ 32-bit RISC core running up to 64MHz and high-speed embedded flash memory (SRAM maximum 4KB, program/data flash 32KB). This product integrates I<sup>2</sup>C, SPI, UART, LIN multiple standard interfaces. Integrated 12bitA/D converter, temperature sensor, 8bitD/A converter, comparator, programmable gain amplifier. Among them, the 12bitA/D converter can collect external sensor signals to reduce the system design cost. The temperature integrated sensor can realize real-time monitoring of the external ambient temperature.

BAT32G133 has particularly excellent low-power performance, with two low-power modes of sleep and deep sleep, to flexible design for users. Its operating power consumption is 35uA/MHz@64MHz, and the power consumption in deep sleep mode is only 0.45uA, which is suitable for battery-powered low-power devices. At the same time, due to the integrated event link controller, direct connection between hardware modules can be achieved without CPU intervention, which is faster than the use of interrupt response, while reducing the CPU's activity frequency and extending battery life.

These characteristics make the BAT32G133 microcontroller series widely applicable to alarm, sensor, smart locks and other smart home equipment, wireless monitoring equipment, portable devices that require power consumption, etc.

## 1.2 Product Model List

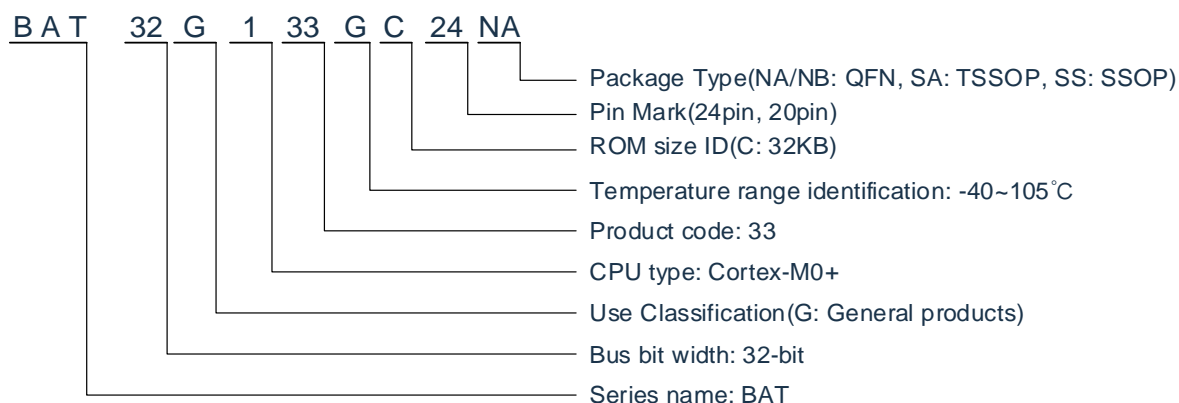

Product List for BAT32G133:

Number of pins	Package	Application	Product model
20pins	20-pin plastic package TSSOP (6.5x4.4mm, 0.65mm pitch)	Consumption Home appliances Industrial control	BAT32G133GC20SA
	20-pin plastic package QFN (3x3mm, 0.4mm pitch)	Consumption Home appliances Industrial control	BAT32G133GC20NB
24pins	24-pin plastic package SSOP (8.65x3.9mm, 0.635mm pitch)	Consumption Home appliances Industrial control	BAT32G133GC24SS
	24-pin plastic package QFN (4x4mm, 0.5mm pitch)	Consumption Home appliances Industrial control	BAT32G133GC24NA

FLASH, SRAM:

Flash memory	Special data flash memory	SRAM	BAT32G133	
			20 pins	24 pins
32KB	1.5KB	4KB	BAT32G133G20	BAT32G133GC24

## 1.3 Pin Configuration (Top View)

### 1.3.1 BAT32G133GC20SA

- 20-pin plastic package TSSOP(6.5x4.4mm, 0.65mm pitch)



Remark: Digital function supports any pin configuration except P00.

## 1.3.2 BAT32G133GC20NB

- 20-pin plastic package QFN(3x3mm, 0.4mm pitch)

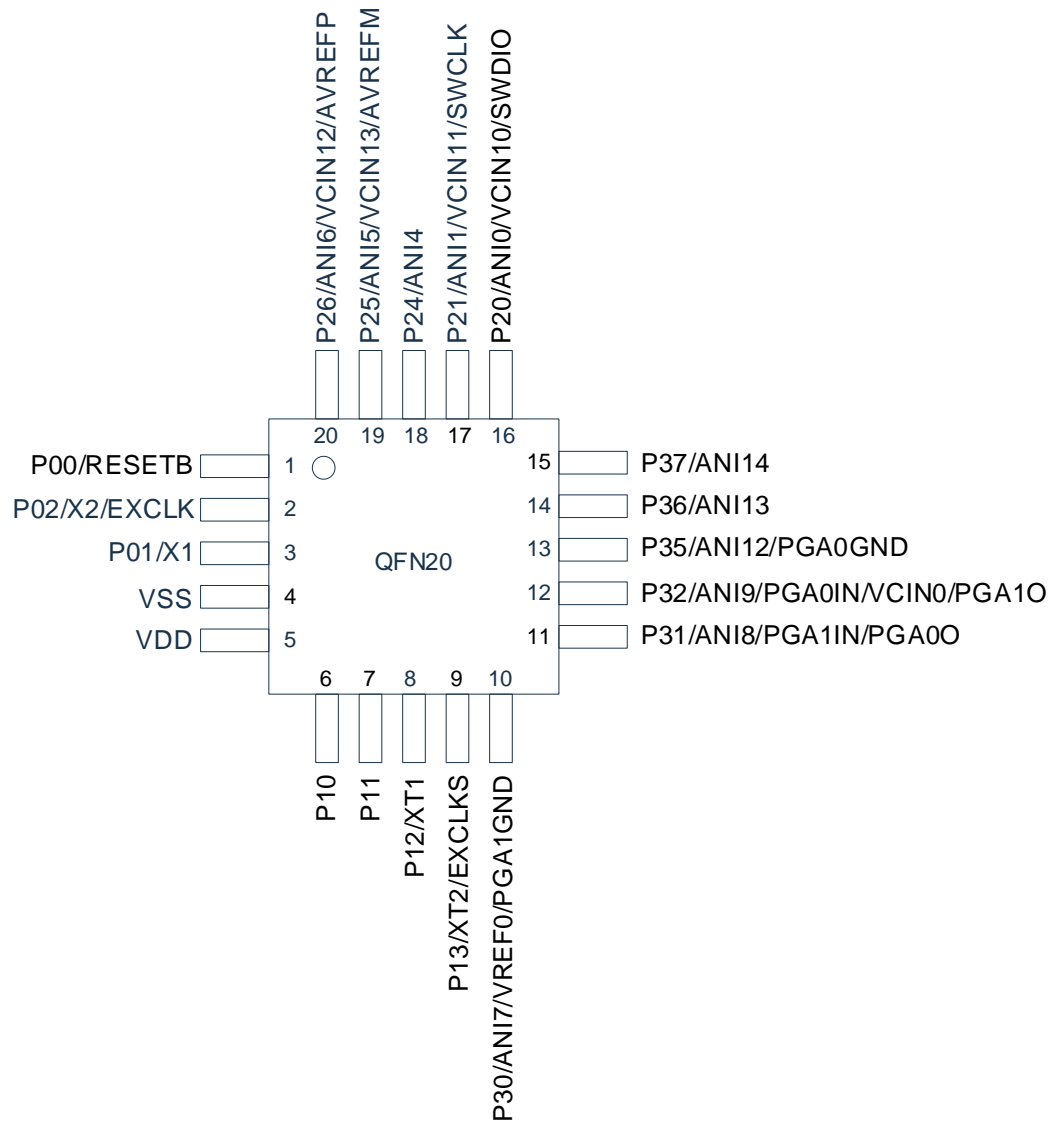

Remark: Digital function supports any pin configuration except P00.

### 1.3.3 BAT32G133GC24SS

- 24-pin plastic package SSOP(8.65x3.9mm, 0.635mm pitch)

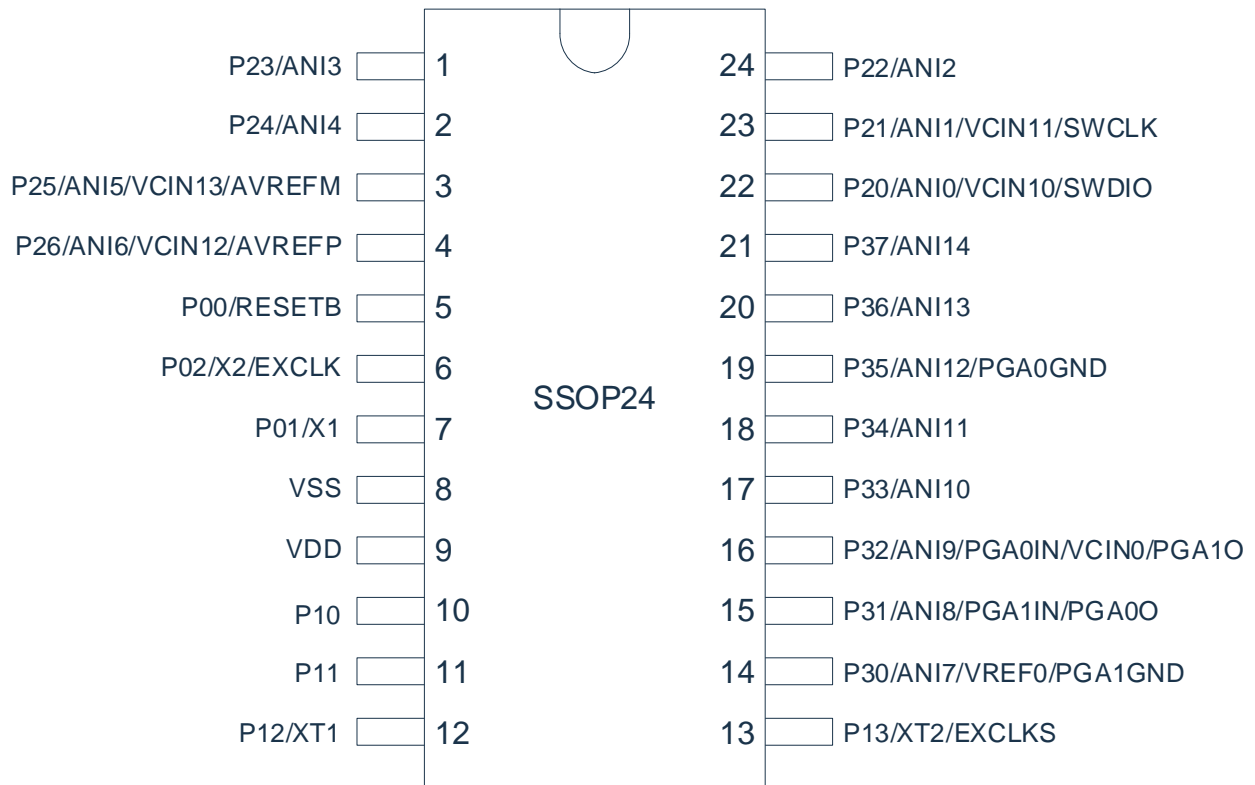

Remark: Digital function supports any pin configuration except P00.



### 1.3.4 BAT32G133GC24NA

- 24-pin plastic package QFN (4x4mm, 0.5mm pitch)

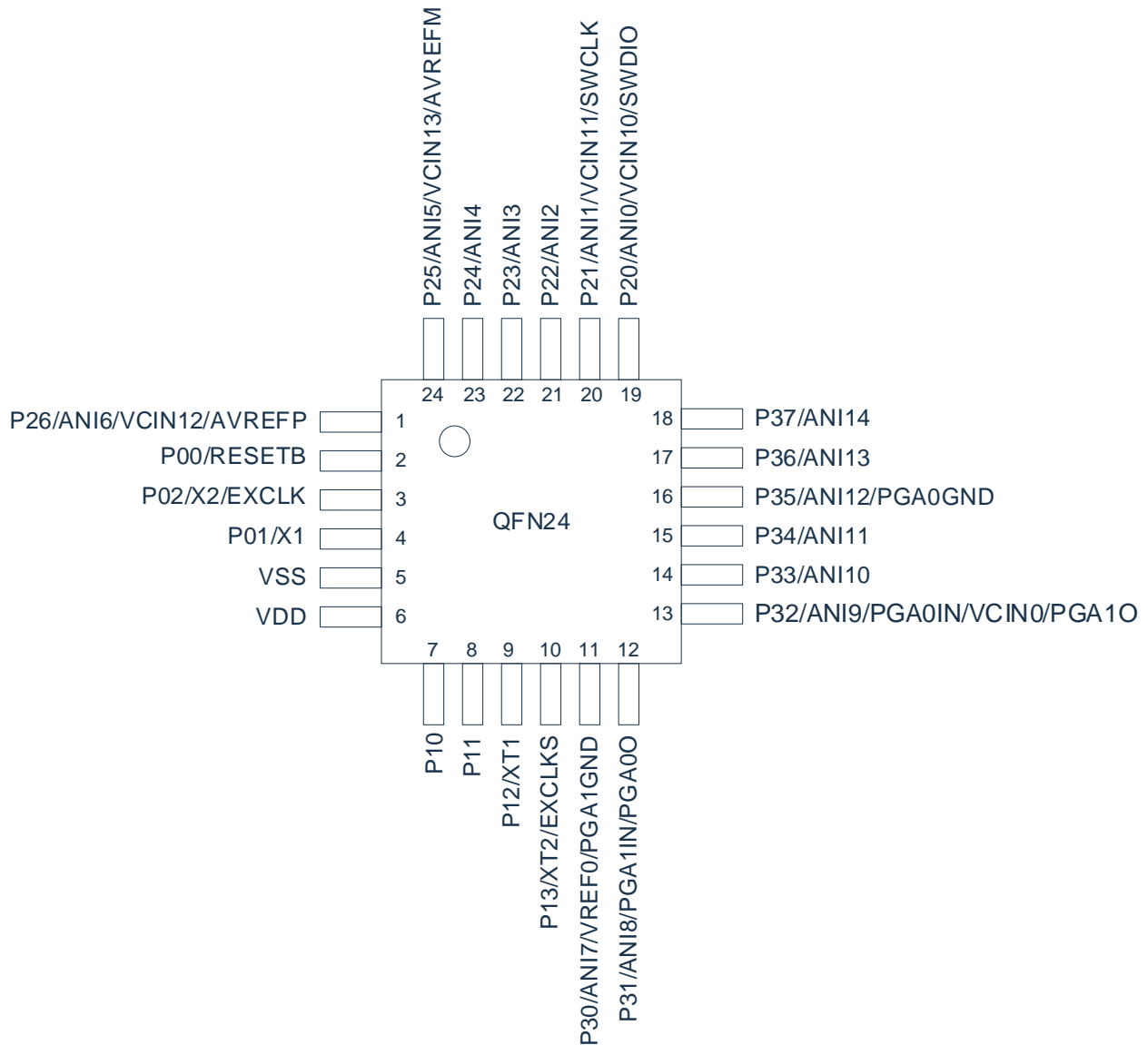

Remark: Digital function supports any pin configuration except P00.

# 2 Block Diagram

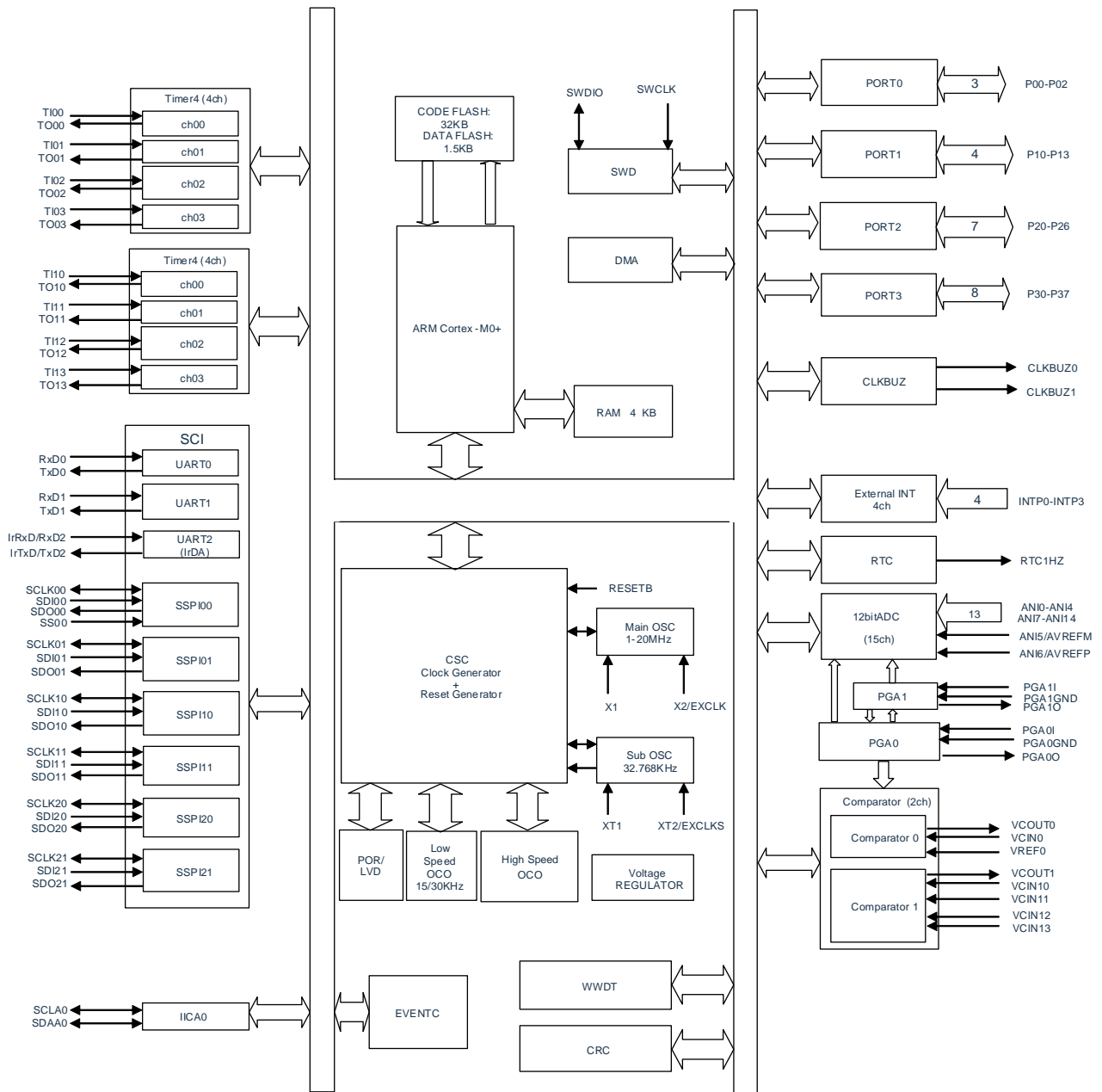

## 3 Memory Space

FFFF_FFFFH	Keep
E00F_FFFFH	Cortex-M0+ dedicated peripheral area
E000_0000H	
4005_FFFFH	Keep
4000_0000H	Peripheral resource area
2000_0FFFH	
2000_0000H	SRAM (Max 4KB)
0050_05FFFH	Keep
0050_0000H	
0000_7FFFH	Data flash 1.5KB
0000_0000H	Keep
0000_0000H	
	Main flash Area (Max 32KB)

## 4 PIN Funtions

### 4.1 Port Functions

Port Name	Alternate Function		Pin function configuration registers pxxcfg[5:0]	Pin NO.			
				20TSSOP	20QFN	24SSOP	24QFN
P00	GPIO		00H	4	1	5	2
	RESETB		-				
P01	GPIO		00H	6	3	7	4
	X1		-				
	Digital function	INTP0	02H				
		INTP1	03H				
		INTP2	04H				
		INTP3	05H				
		TI00	06H				
		TI01	07H				
		TI02	08H				
		TI03	09H				
		TI10	0AH				
		TI11	0BH				
		TI12	0CH				
		TI13	0DH				
		TO00	0EH				
		TO01	0FH				
		TO02	10H				
		TO03	11H				
		TO10	12H				
		TO11	13H				
		TO12	14H				
		TO13	15H				
		SCLA0	16H				
		SDAA0	17H				
		CLKBUZ0	18H				
		CLKBUZ1	19H				
		VCOUT0	1AH				
		VCOUT1	1BH				
		RTC1HZ	1CH				
		SS00	1FH				
		SCLK00	20H				
		SCLK01	21H				
		SCLK10	22H				
		SCLK11	23H				
SCLK20	24H						
SCLK21	25H						
SDI00/RxD0	26H						
SDI01	27H						
SDI10/RxD1	28H						
SDI11	29H						
SDI20/RxD2	2AH						

		SDI21	2BH				
		SDO00/TxD0	2CH				
		SDO01	2DH				
		SDO10/TxD1	2EH				
		SDO11	2FH				
		SDO20/TxD2	30H				
		SDO21	31H				
P02	GPIO		00H	5	2	6	3
	X2/EXCLK		-				
	Digital function	Same as P01	X				
P10	GPIO		00H	9	6	10	7
	Digital function	Same as P01	X				
P11	GPIO		00H	10	7	11	8
	Digital function	Same as P01	X				
P12	GPIO		00H	11	8	12	9
	XT1		-				
	Digital function	Same as P01	X				
P13	GPIO		00H	12	9	13	10
	XT2/EXCLKS		-				
	Digital function	Same as P01	X				
P20	GPIO		00H	19	16	22	19
	ANI0		-				
	VCIN10		-				
	SWDIO		-				
	Digital function	Same as P01	X				
P21	GPIO		00H	20	17	23	20
	ANI1		-				
	VCIN11		-				
	SWCLK		-				
	Digital function	Same as P01	X				
P22	GPIO		00H	-	-	24	21
	Digital function	Same as P01	X				
P23	GPIO		00H	-	-	1	22
	Digital function	Same as P01	X				
P24	GPIO		00H	1	18	2	23
	Digital function	Same as P01	X				
P25	GPIO		00H	2	19	3	24
	ANI5		-				
	VCIN13		-				
	AVREFM		-				
	Digital function	Same as P01	X				
P26	GPIO		00H	3	20	4	1

	ANI6		-				
	VCIN12		-				
	AVREFP		-				
	Digital function	Same as P01	X				
P30	GPIO		00H	13	10	14	11
	ANI7		-				
	VREF0		-				
	PGA1GND		-				
	Digital function	Same as P01	X				
P31	GPIO		00H	14	11	15	12
	ANI8		-				
	PGA1IN		-				
	PGA0O		-				
	Digital function	Same as P01	X				
P32	GPIO		00H	15	12	16	13
	ANI9		-				
	PGA0IN		-				
	PGA1O		-				
	VCIN0		-				
	Digital function	Same as P01	X				
P33	GPIO		00H	-	-	17	14
	ANI10		-				
	Digital function	Same as P01	X				
P34	GPIO		00H	-	-	18	15
	ANI11		-				
	Digital function	Same as P01	X				
P35	GPIO		00H	16	13	19	16
	ANI12		-				
	PGA0GND		-				
	Digital function	Same as P01	X				
P36	GPIO		00H	17	14	20	17
	ANI13		-				
	Digital function	Same as P01	X				
P37	GPIO		00H	18	15	21	18
	ANI14		-				
	Digital function	Same as P01	X				
V <sub>DD</sub>	Power		-	8	5	9	6
V <sub>SS</sub>	Ground		-	7	4	8	5

Remark:

“-” indicates that there is no need to set the value of pxxcfg[5:0];

“X” means to set the value of pxxcfg[5:0] according to the digital function;

The "-" in the Pin NO. column indicates that the pin is not packaged, and the unpackaged pin does not need to be processed.

## 4.2 Pins Other Than Port Pins

(1/2)

Function Name	I/O	Function
ANI0~ANI14	I	A/D converter analog input
INTP0~INTP3	I	External interrupt request input pin for which the valid edge (rising edge, falling edge, or both rising and falling edges) can be
VCIN0	I	Comparator 0 analog voltage input
VCIN10, VCIN11, VCIN12, VCIN13	I	Comparator 1 analog voltage input/reference voltage input
VREF0	I	Comparator 0 reference voltage input
VCOU0, VCOU1	O	Comparator output
PGA0IN, PGA1IN	I	PGA voltage input
PGA0GND, PGA1GND	I	PGA reference voltage input
CLKBUZ0, CLKBUZ1	O	Clock output/buzzer output
RTC1HZ	O	Real-time clock correction clock (1 Hz) output
RESETB	I	This is the active-low system reset input pin.
IrRxD	I	IrDA receive data
IrTxD	O	IrDA transmit data
RxD0~RxD2	I	Serial data input pins of serial interface UART0 to UART2
TxD0~TxD2	O	Serial data output pins of serial interface UART0 to UART2
SCLK00, SCLK01, SCLK10, SCLK11,	I/O	Serial clock I/O pins of serial interface SSPI00, SSPI01, SSPI10, SSPI11, SSPI20, and SSPI21
SDI00, SDI01, SDI10, SDI11, SDI20, SDI21	I	Serial data input pins of serial interface SSPI00, SSPI01, SSPI10, SSPI11, SSPI20, and SSPI21
SS00	I	Chip select input pin of serial interface SSPI00
SDO00, SDO01, SDO10, SDO11, SDO20, SDO21	O	Serial data output pins of serial interface SSPI00, SSPI01, SSPI10, SSPI11, SSPI20, and SSPI21
SCLA0	I/O	Serial clock I/O pins of serial interface IICA0
SDAA0	I/O	Serial data I/O pins of serial interface IICA0

(2/2)

Function Name	I/O	Function
TI00~TI03	I	The pins for inputting an external count clock/capture trigger
TO00~TO03	O	Timer output pins of 16-bit Timer4
TI10~TI13	I	The pins for inputting an external count clock/capture trigger
TO10~TO13	O	Timer output pins of 16-bit Timer4
X1, X2	-	Resonator connection for main system clock
EXCLK	I	External clock input for main system clock
XT1, XT2	-	Resonator connection for subsystem clock
EXCLKS	I	External clock input for subsystem clock
V <sub>DD</sub>	-	Positive power supply
AVREFP	I	A/D converter reference potential (+ side) input
AVREFM	I	A/D converter reference potential (- side) input
V <sub>SS</sub>	-	Ground
SWDIO	I/O	SWD data line
SWCLK	I	SWD clock line

Remark: Use bypass capacitors (about 0.1 uF) as noise and latch up countermeasures with relatively thick wires at the shortest distance to V<sub>DD</sub> to V<sub>SS</sub> lines.



## 5 Functional Overview

### 5.1 ARM® Cortex®-M0+ Core with MPU

Cortex-M0+ processor is a new generation of ARM processors for embedded systems. It provides a low-cost platform for low pin count and low power consumption microcontrollers, while providing excellent computing performance and advanced system response to interrupts.

The 32-bit RISC processor of the Cortex-M0+ processor provides excellent code efficiency and provides high-performance expectations of the ARM core, which is different from 8-bit and 16-bit devices of the same memory size. The Cortex-M0+ processor has 32 address lines and a storage space of up to 4G.

BAT32G133 uses an embedded ARM core, so it is compatible with all ARM tools and software.

### 5.2 Memory

#### 5.2.1 Flash

The MCU provides an on-chip flash memory support to program, erase and rewrite. Functions is shown in below:

- 32KB Flash Memory (program/data flash).
- 1.5KB Special data Flash memory
- Support sector erase, sector size is 512byte, erase time 4ms
- Support byte/half-word/word (32bit) programming, programming time 24us

#### 5.2.2 SRAM

The MCU provides an on-chip high-speed SRAM module of 4KB with either parity-bit checking.

### 5.3 DMA

The built-in DMA (Direct Memory Access) controller can realize the function of data transfer between memories without using the CPU.

- Support the start of DMA through the interruption of peripheral functions, which can realize real-time control through communication, timer and A/D.
- The transmission source/destination domain is the full address space range. (When the Flash domain is the destination address, you need to preset Flash as the programming mode)
- Support 4 transfer modes (normal transfer mode, repeat transfer mode, block transfer mode and chain transfer mode).

## 5.4 Event Link Controller (EVENTC)

The Event Link Controller (EVENTC) uses the event requests generated by various peripheral modules as source signals to connect them to different modules, allowing direct link between the modules without CPU intervention.

The EVENTC has the following functions:

- It can link event signals together to realize the linkage of peripheral functions.
- There are 15 kinds of event inputs and 3 kinds of event triggers.

## 5.5 Clock Generator

The clock generator generates the clock to be supplied to the CPU and peripheral hardware.

The following three kinds of system clocks and clock oscillators are selectable.

### 5.5.1 Main System Clock

- X1 oscillator: This circuit oscillates a clock of  $F_x = 1$  to 20 MHz by connecting a resonator to X1 pin and X2 pin. Oscillation can be stopped by executing the deep sleep instruction or setting of the MSTOP bit.
- High-speed on-chip oscillator (High-speed OCO): The frequency at which to oscillate can be selected from among  $F_{HOCO} = 64, 48, 32, 24, 16, 12, 8, 6, 4, 3, 2$ , or 1MHz (TYP.) by using the option byte. After a reset release, the CPU always starts operating with this high-speed on-chip oscillator clock. Oscillation can be stopped by executing the deep sleep instruction or setting of the HIOSTOP bit. The frequency specified by using an option byte can be changed by using the high-speed on-chip oscillator frequency select register (HOCODIV).
- X2 external main system clock: An external main system clock ( $F_{EX} = 1$  to 20 MHz) can also be supplied from the EXCLK/X2/P122 pin. An external main system clock input can be disabled by executing the STOP instruction or setting of the MSTOP bit.

### 5.5.2 Subsystem Clock

- XT1 oscillator circuit can pass to pin (XT1 and XT2) connected to the 32.768 KHz resonator to produce 32.768 KHz clock oscillation, and by setting XTSTOP oscillating stop.
- by pin (XT2) input external clock: 32.768 KHz, and by setting XTSTOP bits of the external clock input was invalid.

### 5.5.3 Low-speed On-chip Oscillator

- Low-speed internal oscillator (low-speed OCO): generates clock oscillation of 15KHz or 30KHz (typical value). The low-speed internal oscillator clock cannot be used as the CPU clock. Only the following peripheral hardware can operate through the low speed internal oscillator clock:
- Watchdog timer (WWDT)
- Real-time clock (RTC)
- 15-bit interval timer

## 5.6 Power Management

### 5.6.1 Power Supply

$V_{DD}$ : External power, voltage range 2.0 to 5.5V

### 5.6.2 Power-on-reset Circuit

The power-on-reset circuit (POR) has the following functions.

- Generates internal reset signal at power on. The reset signal is released when the supply voltage ( $V_{DD}$ ) exceeds the detection voltage ( $V_{POR}$ ). Note that the reset state must be retained until the operating voltage becomes in the range defined of POR function. This can be achieved by utilizing the voltage detection circuit or controlling the externally input reset signal.
- Compares supply voltage ( $V_{DD}$ ) and detection voltage ( $V_{PDR}$ ), and then generates internal reset signal when  $V_{DD} < V_{PDR}$ . Note that, after power is supplied, this LSI should be placed in the deep sleep mode, or in the reset state by utilizing the voltage detector or externally input reset signal, before the operation voltage falls below the range defined of POR function. When restarting the operation, make sure that the operation voltage has returned within the range of operation.

### 5.6.3 Voltage Detector

The operation mode and detection voltages ( $V_{LVDH}$ ,  $V_{LVDL}$ ,  $V_{LVD}$ ) for the voltage detector is set by using the option byte. The voltage detector (LVD) has the following functions.

- The LVD circuit compares the supply voltage ( $V_{DD}$ ) with the detection voltage ( $V_{LVDH}$ ,  $V_{LVDL}$ ,  $V_{LVD}$ ), and generates an internal reset or internal interrupt signal.
- The detection level for the power supply detection voltage ( $V_{LVDH}$ ,  $V_{LVDL}$ ,  $V_{LVD}$ ) can be selected by using the option byte as one of 10 levels.
- Operable in deep sleep mode.
- When the power supply rises, before reaching the working voltage range, it must be kept in the reset state through the voltage detection circuit or external reset. When the power supply drops, it must be transferred to deep sleep mode before it is less than the operating voltage range, or set to the reset state by the voltage detection circuit or external reset.
- The range of operating voltage varies with the setting of the user option byte.

## 5.7 Low Power Modes

The product supports two low-power modes with short start-up time:

- Sleep mode: Enter sleep mode by executing the sleep instruction. Sleep mode is a mode that stops the CPU from running the clocks. Before the sleep mode is set, each clock continues to oscillate if the high-speed system clock oscillator circuit, high-speed internal oscillator or sub-system clock oscillator circuit is oscillating. Although this mode does not allow the operating current to drop to the level of the deep sleep mode, it is an effective mode when you want to restart processing immediately by interrupt request or when you want to perform frequent intermittent operation.
- Deepsleep mode: When a WFI instruction is executed while SBYCR.SSBY bit is 1, the MCU enters software deepsleep mode. In this mode, the CPU, most of the on-chip peripheral functions and oscillators stop. However, the contents of the CPU internal registers and SRAM data, the states of on-chip peripheral functions and the I/O Ports are retained. Deepsleep mode allows a significant reduction in power consumption because most of the oscillators stop in this mode.

In either mode, the registers, flags, and data memory retain their contents before being set to standby mode, and also maintain the status of the output latch and output buffer of the input/output port.

## 5.8 Reset Function

The following seven operations are available to generate a reset signal.

- (1) External reset input via RESETB pin
- (2) Internal reset by watchdog timer program loop detection
- (3) Internal reset by comparison of supply voltage and detection voltage of power-on-reset (POR) circuit
- (4) Internal reset by comparison of supply voltage of the voltage detector (LVD) and detection voltage
- (5) Internal reset by RAM parity error
- (6) Internal reset by illegal-memory access
- (7) Software reset

External and internal resets start program execution from the address at 0000H and 0001H when the reset signal is generated.

## 5.9 Interrupts

The Cortex-M0+ processor has a built-in Nested Vectored Interrupt Controller (NVIC) that supports up to 32 interrupt request (IRQ) inputs and one non-maskable interrupt (NMI) input. In addition, the processor supports multiple internal exceptions.

This product extends 32 maskable interrupt requests (IRQ) and 1 non-maskable interrupt (NMI), and can support up to 64 maskable interrupt sources and one non-maskable interrupt source. The actual number of interrupt sources varies by product.

## 5.10 Real-timer Clock (RTC)

The real-time clock has the following features.

- Counters of year, month, week, day, hour, minute, and second.
- Constant-period interrupt function (period: 0.5 seconds, 1 second, 1 minute, 1 hour, 1 day, 1 month)
- Alarm interrupt function (alarm: week, hour, minute)
- Pin output function of 1 Hz
- Support frequency division of sub-system clock or main system clock as RTC running clock
- Real-time clock interrupt signal (INTRTC) can be used to wake up in deep sleep mode
- Support a wide range of clock correction functions

The count of year, month, week, day, hour, minutes and second can only be performed when a subsystem clock ( $F_{SUB} = 32.768$  KHz) is selected as the operation clock of the real-time clock. When the low-speed oscillation clock ( $F_{IL} = 15$  KHz/30KHz) is selected, only the constant-period Interrupt function is available.

## 5.11 Watchdog Timer

The counting operation of the watchdog timer is set by the option byte. The watchdog timer operates on the low-speed on-chip oscillator clock ( $F_{IL} = 15$  KHz/30KHz). The watchdog timer is used to detect an inadvertent program loop. If a program loop is detected, an internal reset signal is generated.

Program loop is detected in the following cases:

- If the watchdog timer counter overflows
- If a 1-bit manipulation instruction is executed on the watchdog timer enable register (WDTE)
- If data other than "ACH" is written to the WDTE register
- If data is written to the WDTE register during a window close period

## 5.12 SysTick Timer

This timer is dedicated to real-time operating systems, but can also be used as a standard down counter.

Its characteristics are: when the 24-bit down counter self-loading capacity counter reaches 0, there is a shieldable system interruption.

## 5.13 Timer4

The Timer4 has eight (two units of four) 16-bit timers. Each 16-bit timer is called a channel and can be used as an independent timer. In addition, two or more “channels” can be used to create a high-accuracy timer.

For details about each function, see the table below.

Independent channel operation function	Simultaneous channel operation function
<ul style="list-style-type: none"> <li>● Interval timer</li> <li>● Square wave output</li> <li>● External event counter</li> <li>● Divider</li> <li>● Input pulse interval measurement</li> <li>● Measurement of high-/low-level width of input signal</li> <li>● Delay counter</li> </ul>	<ul style="list-style-type: none"> <li>● One-shot pulse output</li> <li>● PWM output</li> <li>● Multiple PWM output</li> </ul>

### 5.13.1 Independent Channel Operation Function

By operating a channel independently, it can be used for the following purposes without being affected by the operation mode of other channels.

- (1) Interval timer: Each timer of the unit can be used as a reference timer that generates an interrupt (INTTM) at fixed intervals.
- (2) Square wave output: A toggle operation is performed each time INTTM<sub>mn</sub> interrupt is generated and a square wave with a duty factor of 50% is output from a timer output pin (TO).
- (3) External event counter: Each timer of the unit can be used as an event counter that generates an interrupt when the number of the valid edges of a signal input to the timer input pin (TI) has reached a specific value.
- (4) Divider function (channel 0 only): A clock input from a timer input pin (TI00) is divided and output from an output pin (TO00).
- (5) Input pulse interval measurement: Counting is started by the valid edge of a pulse signal input to a timer input pin (TI). The count value of the timer is captured at the valid edge of the next pulse. In this way, the interval of the input pulse can be measured.
- (6) Measurement of high-/low-level width of input signal: Counting is started by a single edge of the signal input to the timer input pin (TI), and the count value is captured at the other edge. In this way, the high-level or low-level width of the input signal can be measured.
- (7) Delay counter: Counting is started at the valid edge of the signal input to the timer input pin (TI), and an interrupt is generated after any delay period.

## 5.13.2 Simultaneous Channel Operation Function

By using the combination of a master channel (a reference timer mainly controlling the cycle) and slave channels (timers operating according to the master channel), channels can be used for the following purposes.

- (1) One-shot pulse output: Two channels are used as a set to generate a one-shot pulse with a specified output timing and a specified pulse width.
- (2) PWM (Pulse Width Modulation) output: Two channels are used as a set to generate a pulse with a specified period and a specified duty factor.
- (3) Multiple PWM (Pulse Width Modulation) output: By extending the PWM function and using one master channel and two or more slave channels, up to three types of PWM signals that have a specific period and a specified duty factor can be generated.

## 5.13.38-bit Timer Operation Function

The 8-bit timer operation function makes it possible to use a 16-bit timer channel in a configuration consisting of two 8-bit timer channels. (This function can only be used for channels 1 and 3.)

## 5.14 15-bit Interval Timer

An interrupt (INTIT) is generated at any previously specified time interval. It can be utilized for wakeup from deep sleep mode.

## 5.15 Clock Output/Buzzer Output Controller

The clock output controller is intended for clock output for supply to peripheral ICs. Buzzer output is a function to output a square wave of buzzer frequency.



## 5.16 Serial Communication Interface (SCI)

This product has two serial array units. Serial array unit has four serial channels. All channels can achieve UART, simplified SPI (3-wire serial) and simplified I<sup>2</sup>C. Function assignment of each channel is as shown below.

### 5.16.13-wire Serial I/O (SSPI)

Data is transmitted or received in synchronization with the serial clock (SCK) output from the master channel. 3-wire serial communication is clocked communication performed by using three communication lines: one for the serial clock (SCK), one for transmitting serial data (SO), one for receiving serial data (SI).

[Data transmission/reception]

- Data length of 7 or 8 bits
- Phase control of transmit/receive data
- MSB/LSB first selectable

[Clock control]

- Master/slave selection
- Phase control of I/O clock
- Setting of transfer period by prescaler and internal counter of each channel
- Maximum transfer rate

During master communication: Max.  $F_{CLK}/2$

During slave communication: Max.  $F_{MCK}/6$

[Interrupt function]

- Transfer end interrupt/buffer empty interrupt

[Error detection flag]

- Overrun error

## 5.16.24-wire Serial I/O with Slave Select Input Function

This is a clock synchronization using a slave chip select input (SSI), a serial clock (SCK), a transmit serial data (SO) and a receive serial data (SI) a total of 4 communication lines for communication Communication Interface.

[Data transmission/reception]

- Data length of 7 or 8 bits
- Phase control of transmit/receive data
- MSB/LSB first selectable
- Level setting of transmit/receive data

[Clock control]

- Phase control of I/O clock
- Setting of transfer period by prescaler and internal counter of each channel
- Maximum transfer rate

During slave communication: Max.  $F_{MCK}/6$

[Interrupt function]

- Transfer end interrupt/buffer empty interrupt

[Error detection flag]

- Overrun error

## 5.16.3UART

This is a start-stop synchronization function using two lines: serial data transmission (TxD) and serial data reception (Rx) lines. By using these two communication lines, each data frame, which consists of start bit, data, parity bit and stop bit, is transferred asynchronously (using the internal baud rate) between the microcontroller and the other communication party. Full-duplex UART communication can be performed by using a channel dedicated to transmission (even-numbered channel) and a channel dedicated to reception (odd-numbered channel). The LIN-bus can be implemented by using UART0, Timer4 unit 0 (channel 3), and an external interrupt (INTP0).

### [Data transmission/reception ]

- Data length of 7, 8, or 9 bits
- Select the MSB/LSB first
- Level setting of transmit/receive data (selecting whether to reverse the level)
- Parity bit appending and parity check functions
- Stop bit appending, stop bit check function

### [Interrupt function]

- Transfer end interrupt/buffer empty interrupt
- Error interrupt in case of framing error, parity error, or overrun error

### [Error detection flag]

- Framing error, parity error, or overrun error

### [LIN-bus functions ]

- Wakeup signal detection
- Break field (BF) detection
- Sync field measurement, baud rate calculation

## 5.17 Serial Interface IICA

Serial interface IICA has the following three modes.

- Operation stop mode: This mode is used when serial transfers are not performed. It can reduce power consumption.
- I<sup>2</sup>C bus mode (multi-master application supported): This mode is used for 8-bit data transfers with several devices via two lines: a serial clock (SCLAn) line and a serial data bus (SDAAn) line. It complies with the I<sup>2</sup>C bus format and the master device can generate “start condition”, “address”, “transfer direction specification”, “data”, and “stop condition” data to the slave device, via the serial data bus. The slave device automatically detects these received status and data by hardware. It can simplify the part of application program that controls the I<sup>2</sup>C bus. Since the SCLA and SDAA pins are used for open drain outputs, serial interface IICA requires pull-up resistors for the serial clock line and the serial data bus line.
- Wakeup mode: The deep sleep mode can be released by generating an interrupt request signal (INTIICA) when an extension code from the master device or a local address has been received while in deep sleep mode.

## 5.18 A/D Converter (ADC)

The A/D converter is a converter that converts analog input signals into digital values, and is configured to control analog inputs, including up to 15 channels of A/D converter analog inputs (ANI0 to ANI14). The A/D converter has the following function:

- 12-bit resolution A/D conversion, Conversionrate 1.42Mps.
- Trigger mode: Software trigger, Hardware trigger mode
- Channel selection: Single channel select mode and Scan mode
- Conversion operation mode: One-shot conversion mode and Sequential conversion mode
- Operation voltage:  $2.0V \leq V_{DD} \leq 5.5V$
- Can detect the internal reference voltage (1.45V) and temperature sensor.

Various A/D conversion modes can be specified by using the mode combinations below.

Trigger mode	Software trigger	Conversion is started by software.
	Hardware trigger no-wait	Conversion is started by detecting a hardware trigger.
	Hardware trigger wait mode	The power is turned on by detecting a hardware trigger while the system is off and in the conversion standby state, and conversion is then started
Channel selection mode	Select mode	A/D conversion is performed on the analog input of one selected
	Scan mode	A/D conversion is performed on the analog input of four channels in order. Four consecutive channels can be selected from ANI0 to ANI15 as analog input channels.
Conversion operation mode	One-shot conversion mode	A/D conversion is performed on the selected channel once.
	Sequential conversion mode	A/D conversion is sequentially performed on the selected channels until it is stopped by software.
Sampling time/ Conversion time	Sampling clock cycles / Conversion clock cycles	The sampling time can be set by the register. The default value of the sampling clock is 13.5 clk, and the conversion clock number Min is 31.5 clk.

## 5.19 Programmable Gain Amplifier (PGA)

This product has two programmable gain amplifiers (PGA0, PGA1), The programmable gain amplifier is provided with the following functions.

- GAIN: X4, X8, X10, X12, X14, X16, X32
- The external pin (PGAGND) can be selected as the ground of the negative feedback resistance of the PGA (can be used as a differential mode)
- The output of PGA0 can be selected as the analog input for the A/D converter or the analog input of the positive terminal of comparator 0 (CMP0)
- PGA1 output can be selected as analog input for A/D converter

## 5.20 Comparator (CMP)

The product has two comparator channels. The comparator has the following functions.

- A pin selector switch is added to the analog input of CMP1.
- The external reference voltage input or internal reference voltage can be selected as the reference voltage.
- The canceling width of the noise canceling digital filter can be selected.
- An interrupt signal can be generated by detecting an active edge of the comparator output.
- An event link controller (EVENTC) event signal can be output by detecting an active edge of the comparator output.

## 5.21 Serial Wire Debug (SW-DP)

SW-DP interface allows connection to the microcontroller via serial line debugging tools.

## 5.22 Safety Functions

### 5.22.1 Flash Memory CRC Operation Function (High-speed CRC, General-purpose CRC)

This detects data errors in the flash memory by performing CRC operations.

Two CRC functions are provided according to the different applications.

- High-speed CRC: The CPU can be stopped and a high-speed check executed on its entire code flash memory area during the initialization routine.
- General CRC: This can be used for checking various data in addition to the code flash memory area while the CPU is running.

### 5.22.2 RAM Parity Error Detection Function

This detects parity errors when the RAM is read as data.

### 5.22.3 SFR Guard Function

This prevents SFRs (Special Function Register) from being rewritten when the CPU freezes.

### 5.22.4 Invalid Memory Access Detection Function

This detects illegal accesses to invalid memory areas.

### 5.22.5 Frequency Detection Function

This uses the Timer4 to perform a self-check of the CPU/peripheral hardware clock frequency.

### 5.22.6 A/D Test Function

This is used to perform a self-check of A/D converter by performing A/D conversion on the positive internal reference voltage, negative reference voltage, analog input channel (ANI), temperature sensor output, and internal reference voltage output.

## 5.22.7 Digital Output Signal Level Detection Function

When the I/O pins are output mode, the output level of the pin can be read.



# 6 Electrical Characteristics

## 6.1 Typical Application Peripheral Circuit

The connection reference of the MCU typical application peripheral circuit is as follows:

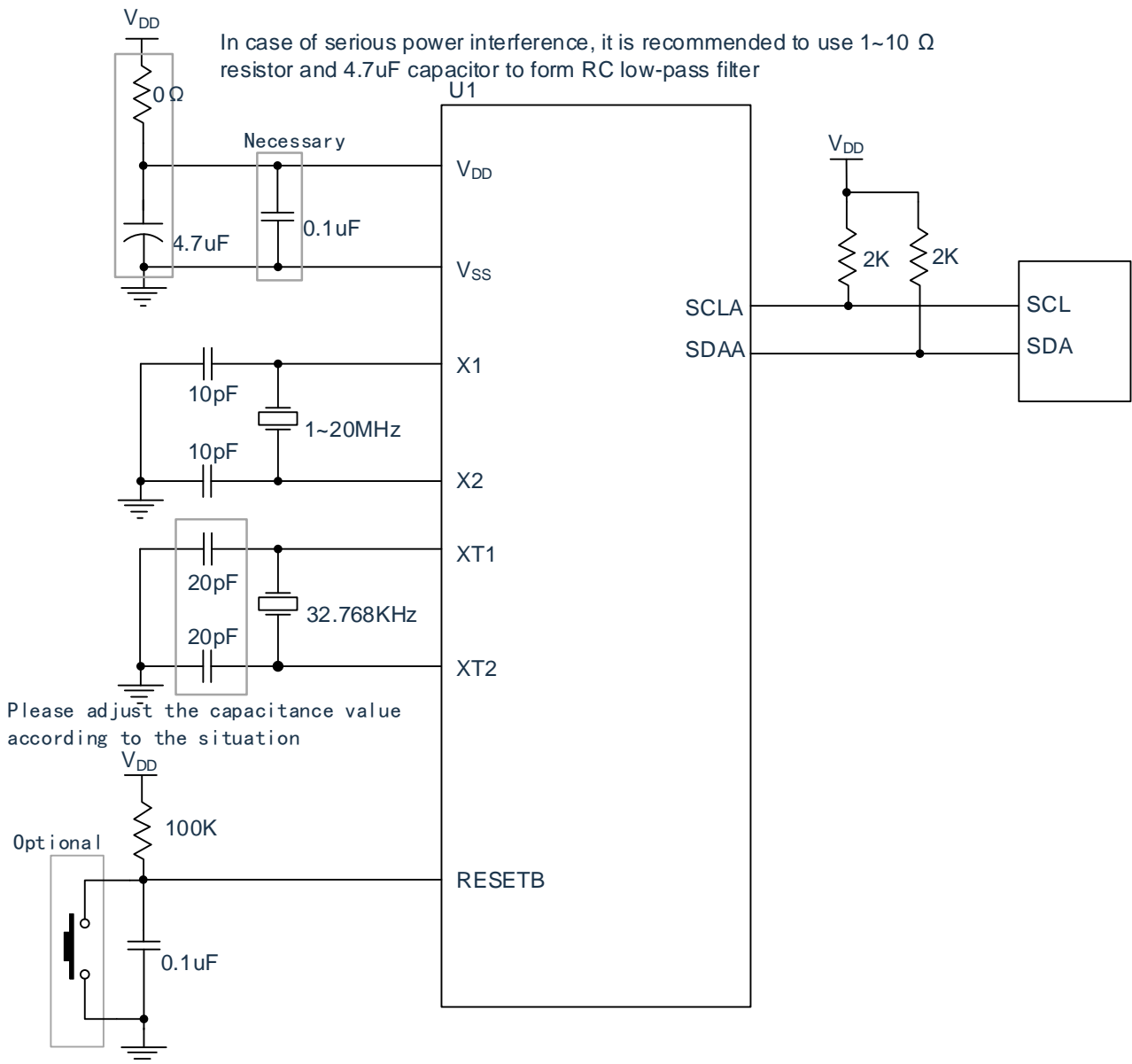

## 6.2 Absolute Maximum Voltage Ratings

( $T_A = -40 \sim 105^\circ\text{C}$ )

Parameter	Symbols	Conditions	Ratings	Unit
Supply voltage	$V_{DD}$	-	-0.5~+6.5	V
Input voltage	$V_I$	P00~P02, P10~P13, P20~P26 P30~P37, EXCLK, EXCLKS, RESETB	-0.3~ $V_{DD}+0.3$ <sup>Note1</sup>	V
Output voltage	$V_O$	P01~P02, P10~P13, P20~P26, P30~P37	-0.3~ $V_{DD}+0.3$ <sup>Note1</sup>	V
Analog input voltage	$V_{AI}$	ANI0~ANI14	-0.3~ $V_{DD}+0.3$ and -0.3~ $AV_{REF}(+)+0.3$ <sup>Note1,2</sup>	V

Note1: Must be 6.5 V or lower.

Note2: Do not exceed  $AV_{REF}(+) + 0.3V$  in case of A/D conversion target pin.

Caution: Product quality may suffer if the absolute maximum rating is exceeded even momentarily for any parameter. That is, the absolute maximum ratings are rated values at which the product is on the verge of suffering physical damage, and therefore the product must be used under conditions that ensure that the absolute maximum ratings are not exceeded.

Remark:

1. Unless specified otherwise, the characteristics of alternate-function pins are the same as those of the port pins.
2.  $AV_{REF}(+)$ : + side reference voltage of the A/D converter.
3.  $V_{SS}$ : Reference voltage
4. Low temperature specification value shall be guaranteed by the design, and low temperature conditions shall not be measured in mass production.

## 6.3 Absolute Maximum Current Ratings

( $T_A = -40 \sim 105^\circ\text{C}$ )

Parameter	Symbols	Conditions		Ratings	Unit
High level Output current	$I_{OH1}$	Per pin	P10~P11, P20~P26, P30~P37	-40	mA
		Total of all pins	P10~P11, P20~P26, P30~P37	-170	mA
	$I_{OH2}$	Per pin	P01~P02, P12~P13	-0.5	mA
		Total of all pins		-2	mA
Low level Output current	$I_{OL1}$	Per pin	P10~P11, P20~P26, P30~P37	40	mA
		Total of all pins	P10~P11, P20~P26, P30~P37	170	mA
	$I_{OL2}$	Per pin	P01~P02, P12~P13	1	mA
		Total of all pins		5	mA
Operating ambient temperature	$T_A$	In normal operation mode		-40~105	$^\circ\text{C}$
		In flash memory programming mode			
Storage temperature	$T_{stg}$	-		-65~150	$^\circ\text{C}$

Caution: Product quality may suffer if the absolute maximum rating is exceeded even momentarily for any parameter. That is, the absolute maximum ratings are rated values at which the product is on the verge of suffering physical damage, and therefore the product must be used under conditions that ensure that the absolute maximum ratings are not exceeded.

Remark:

1. Unless specified otherwise, the characteristics of alternate-function pins are the same as those of the port pins.
2. Low temperature specification value shall be guaranteed by the design, and low temperature conditions shall not be measured in mass production.

## 6.4 Oscillator Characteristics

### 6.4.1 X1, XT1 Characteristics

( $T_A = -40 \sim 105^\circ\text{C}$ ,  $2.0\text{V} \leq V_{DD} \leq 5.5\text{V}$ ,  $V_{SS} = 0\text{V}$ )

Item	Resonator	Conditions	Min	Typ	Max	Unit
X1 clock oscillation frequency ( $F_X$ )	Ceramic resonator/ crystal resonator	$2.0\text{V} \leq V_{DD} \leq 5.5\text{V}$	1.0	-	20.0	MHz
XT1 clock oscillation frequency ( $F_{XT}$ )	Crystal resonator	$2.0\text{V} \leq V_{DD} \leq 5.5\text{V}$	32	32.768	35	KHz

Remark:

1. Indicates only permissible oscillator frequency ranges. Refer to AC Characteristics for instruction execution time.
2. Request evaluation by the manufacturer of the oscillator circuit mounted on a board to check the oscillator characteristics.
3. Low temperature specification value shall be guaranteed by the design, and low temperature conditions shall not be measured in mass production.

### 6.4.2 On-chip Oscillator Characteristics

( $T_A = -40 \sim 105^\circ\text{C}$ ,  $2.0\text{V} \leq V_{DD} \leq 5.5\text{V}$ ,  $V_{SS} = 0\text{V}$ )

Resonator	Conditions	Min	Typ	Max	Unit
High-speed on-chip oscillator clock frequency ( $F_{IH}$ ) <sup>Note1,2</sup>	-	2.0	-	64.0	MHz
High-speed on-chip oscillator clock frequency accuracy	$T_A = 10 \sim 50^\circ\text{C}$	-1.0	-	+1.0	%
	$T_A = 0 \sim 105^\circ\text{C}$	-3.0	-	+4.0	%
	$T_A = -10 \sim 105^\circ\text{C}$	-5.0	-	+4.0	%
	$T_A = -40 \sim 105^\circ\text{C}$	-8.0	-	+4.0	%
Low-speed on-chip oscillator clock frequency ( $F_{IL}$ )	-	10	15	20	KHz
-	-	20	30	40	KHz

Note:

1. High-speed on-chip oscillator frequency is selected with the option byte and HOCODIV register.
2. This only indicates the oscillator characteristics. Refer to AC Characteristics for instruction execution time.

Remark: Low temperature specification value shall be guaranteed by the design, and low temperature conditions shall not be measured in mass production.

## 6.5 DC Characteristics

### 6.5.1 Pin Characteristics

( $T_A = -40 \sim 105^\circ\text{C}$ ,  $2.0\text{V} \leq V_{DD} \leq 5.5\text{V}$ ,  $V_{SS} = 0\text{V}$ )

Items	Symbols	Conditions	Min	Typ	Max	Unit	
High level Output current Note1	I <sub>OH1</sub>	Per pin for P10~P11 P20~P26, P30~P37	$2.0\text{V} \leq V_{DD} \leq 5.5\text{V}$ -40~85°C	-	-	-10.0 <sup>Note2</sup>	mA
			$2.0\text{V} \leq V_{DD} \leq 5.5\text{V}$ 85~105°C	-	-	-3.0 <sup>Note2</sup>	
		Total pins (when duty cycle $\leq 70\%$ <sup>Note3</sup> )	$2.0\text{V} \leq V_{DD} \leq 5.5\text{V}$ -40~85°C	-	-	-135.0	mA
			$2.0\text{V} \leq V_{DD} \leq 5.5\text{V}$ 85~105°C	-	-	-60.0	
	I <sub>OH2</sub>	Per pin for P01~P02 P12~P13	$2.0\text{V} \leq V_{DD} \leq 5.5\text{V}$	-	-	-0.1 <sup>Note2</sup>	mA
		Total pins (when duty cycle $\leq 70\%$ <sup>Note3</sup> )	$2.0\text{V} \leq V_{DD} \leq 5.5\text{V}$	-	-	-1.5	mA

Note1: Value of current at which the device operation is guaranteed even if the current flows from the  $V_{DD}$  pins to an output pin.

Note2: Do not exceed the total current value.

Note3: Specification under conditions where the duty factor  $\leq 70\%$ .

The output current value that has changed to the duty factor  $> 70\%$  the duty ratio can be calculated with the following expression (when changing the duty factor from 70% to n%).

- Total output current of pins =  $(I_{OH} \times 0.7) / (n \times 0.01)$

<Example> Where  $n = 80\%$  and  $I_{OH} = -10.0\text{ mA}$

Total output current of pins =  $(-10.0 \times 0.7) / (80 \times 0.01) \approx -8.7\text{ mA}$

However, the current that is allowed to flow into one pin does not vary depending on the duty factor.

A current higher than the absolute maximum rating must not flow into one pin.

Remark:

1. Unless specified otherwise, the characteristics of alternate-function pins are the same as those of the port pins.
2. Low temperature specification value shall be guaranteed by the design, and low temperature conditions shall not be measured in mass production.

$(T_A = -40 \sim 105^\circ\text{C}, 2.0\text{V} \leq V_{DD} \leq 5.5\text{V}, V_{SS} = 0\text{V})$ 

Items	Symbol	Conditions	Min	Typ	Max	Unit	
Low level Output current Note1	I <sub>OL1</sub>	Per pin for P10~P11, P20~P26 P30~P37	2.0V ≤ V <sub>DD</sub> ≤ 5.5V -40~85°C	-	-	20.0 <sup>Note2</sup>	mA
			2.0V ≤ V <sub>DD</sub> ≤ 5.5V 85~105°C	-	-	8.5 <sup>Note2</sup>	
		Total pins (when duty cycle ≤ 70% <sup>Note3</sup> )	2.0V ≤ V <sub>DD</sub> ≤ 5.5V -40~85°C	-	-	150.0	mA
			2.0V ≤ V <sub>DD</sub> ≤ 5.5V 85~105°C	-	-	80.0	
	I <sub>OL2</sub>	Per pin for P01~P02, P12~P13	2.0V ≤ V <sub>DD</sub> ≤ 5.5V	-	-	0.4 <sup>Note2</sup>	mA
		Total pins (when duty cycle ≤ 70% <sup>Note3</sup> )	2.0V ≤ V <sub>DD</sub> ≤ 5.5V	-	-	5.0	mA

Note1: Value of current at which the device operation is guaranteed even if the current flows from an output pin to the V<sub>SS</sub> pins.

Note2: Do not exceed the total current value.

Note3: Specification under conditions where the duty factor ≤ 70%.

The output current value that has changed to the duty factor > 70% the duty ratio can be calculated with the following expression (when changing the duty factor from 70% to n%).

- Total output current of pins =  $(I_{OL} \times 0.7) / (n \times 0.01)$

<Example> Where n = 80% and I<sub>OL</sub> = 10.0 mA

$$\text{Total output current of pins} = (10.0 \times 0.7) / (80 \times 0.01) \approx 8.7 \text{ mA}$$

However, the current that is allowed to flow into one pin does not vary depending on the duty factor.

A current higher than the absolute maximum rating must not flow into one pin.

Remark:

1. Unless specified otherwise, the characteristics of alternate-function pins are the same as those of the port pins.
2. Low temperature specification value shall be guaranteed by the design, and low temperature conditions shall not be measured in mass production.

$(T_A = -40 \sim 105^\circ\text{C}, 2.0\text{V} \leq V_{DD} \leq 5.5\text{V}, V_{SS} = 0\text{V})$ 

Items	Symbol	Conditions	Min	Typ	Max	Unit	
High level input voltage	$V_{IH1}$	P00~P02, P12~P13, P20~P26 P30~P37	Schmitt input	$0.8V_{DD}$	-	$V_{DD}$	V
	$V_{IH2}$	P10~P11	CMOS input	$0.7V_{DD}$	-	$V_{DD}$	V
Low level input voltage	$V_{IL1}$	P00~P02, P12~P13, P20~P26 P30~P37	Schmitt input	0	-	$0.2V_{DD}$	V
	$V_{IL2}$	P10~P11	CMOS input	0	-	$0.3V_{DD}$	V

Remark:

1. Unless specified otherwise, the characteristics of alternate-function pins are the same as those of the port pins.
2. Low temperature specification value shall be guaranteed by the design, and low temperature conditions shall not be measured in mass production.

$(T_A = -40 \sim 105^\circ\text{C}, 2.0\text{V} \leq V_{DD} = V_{DD} \leq 5.5\text{V}, V_{SS} = V_{SS} = 0\text{V})$ 

Items	Symbol	Conditions	Min	Typ	Max	Unit	
High level output voltage	$V_{OH1}$	P10~P11, P20~P26, P30~P37	$4.0\text{V} \leq V_{DD} \leq 5.5\text{V}$ $I_{OH1} = -10.0\text{mA}$ <small>Note1</small>	$V_{DD}-1.5$	-	-	V
			$4.0\text{V} \leq V_{DD} \leq 5.5\text{V}$ $I_{OH1} = -3.0\text{mA}$	$V_{DD}-0.7$	-	-	V
			$2.4\text{V} \leq V_{DD} \leq 5.5\text{V}$ $I_{OH1} = -3.0\text{mA}$	$V_{DD}-0.6$	-	-	V
			$2.0\text{V} \leq V_{DD} \leq 5.5\text{V}$ $I_{OH1} = -1.5\text{mA}$	$V_{DD}-0.5$	-	-	V
	$V_{OH2}$	P01~P02, P12~P13	$2.0\text{V} \leq V_{DD} \leq 5.5\text{V}$ $I_{OH2} = -100\mu\text{A}$	$V_{DD}-0.5$	-	-	V
Low level output voltage	$V_{OL1}$	P10~P11, P20~P26, P30~P37	$4.0\text{V} \leq V_{DD} \leq 5.5\text{V}$ $I_{OL1} = 20.0\text{mA}$ <small>Note1</small>	-	-	1.3	V
			$4.0\text{V} \leq V_{DD} \leq 5.5\text{V}$ $I_{OL1} = 8.5\text{mA}$	-	-	0.7	V
			$2.4\text{V} \leq V_{DD} \leq 5.5\text{V}$ $I_{OL1} = 3.0\text{mA}$	-	-	0.6	V
			$2.4\text{V} \leq V_{DD} \leq 5.5\text{V}$ $I_{OL1} = 1.5\text{mA}$	-	-	0.4	V
			$2.0\text{V} \leq V_{DD} \leq 5.5\text{V}$ $I_{OL1} = 0.6\text{mA}$	-	-	0.4	V
	$V_{OL2}$	P01~P02, P12~P13	$2.0\text{V} \leq V_{DD} \leq 5.5\text{V}$ $I_{OL2} = 400\mu\text{A}$	-	-	0.4	V

Note1: Operating ambient temperature is  $-40 \sim 85^\circ\text{C}$ .

Remark:

1. Unless specified otherwise, the characteristics of alternate-function pins are the same as those of the port pins.
2. Low temperature specification value shall be guaranteed by the design, and low temperature conditions shall not be measured in mass production.



$(T_A = -40 \sim 105^\circ\text{C}, 2.0\text{V} \leq V_{DD} \leq 5.5\text{V}, V_{SS} = 0\text{V})$ 

Items	Symbol	Conditions	Min	Typ	Max	Unit	
High level input leakage current	$I_{LH1}$	P00, P10~P11 P20~P26, P30~P37	$V_I = V_{DD}$	-	-	1	$\mu\text{A}$
	$I_{LH2}$	RESETB	$V_I = V_{DD}$	-	-	1	$\mu\text{A}$
	$I_{LH3}$	P01~P02, P12~P13 (X1, X2, EXCLK XT1, XT2, EXCLKS)	$V_I = V_{DD}$ In input port or external clock input	-	-	1	$\mu\text{A}$
			$V_I = V_{DD}$ In resonator connection	-	-	10	$\mu\text{A}$
Low level input leakage current	$I_{LIL1}$	P00, P10~P11 P20~P26, P30~P37	$V_I = V_{SS}$	-	-	-1	$\mu\text{A}$
	$I_{LIL2}$	RESETB	$V_I = V_{SS}$	-	-	-1	$\mu\text{A}$
	$I_{LIL3}$	P01~P02, P12~P13 (X1, X2, EXCLK XT1, XT2, EXCLKS)	$V_I = V_{SS}$ In input port or external clock input	-	-	-1	$\mu\text{A}$
			$V_I = V_{SS}$ In resonator connection	-	-	-10	$\mu\text{A}$
On-chip pull-up resistance	$R_U$	P00, P10~P11 P20~P26, P30~P37	$V_I = V_{SS}$ In input port	10	30	100	$\text{k}\Omega$
On-chip pull-down resistance	$R_D$	P20~P26, P30~P37	$V_I = V_{DD}$ In input port	10	30	100	$\text{k}\Omega$

Remark:

1. Unless specified otherwise, the characteristics of alternate-function pins are the same as those of the port pins.
2. Low temperature specification value shall be guaranteed by the design, and low temperature conditions shall not be measured in mass production.

## 6.5.2 Supply Current Characteristics

( $T_A = -40 \sim 105^\circ\text{C}$ ,  $2.0\text{V} \leq V_{DD} \leq 5.5\text{V}$ ,  $V_{SS} = 0\text{V}$ )

Parameter	Symbol	Conditions		Min	Typ	Max	Unit			
Supply current <sup>Note1</sup>	I <sub>DD1</sub>	Operating mode	High-speed on-chip oscillator	F <sub>HOCO</sub> = 64MHz, F <sub>IH</sub> = 64MHz <sup>Note3</sup>	-	2.2	6.1	mA		
				F <sub>HOCO</sub> = 48MHz, F <sub>IH</sub> = 48MHz <sup>Note3</sup>	-	1.9	5.4			
				F <sub>HOCO</sub> = 8MHz, F <sub>IH</sub> = 8MHz <sup>Note3</sup>	-	0.6	1.4			
			high-speed main clock	F <sub>MX</sub> = 20MHz <sup>Note2</sup>	Square	-	0.9	2.8	mA	
					Resonator	-	0.9	2.8		
			high-speed SUB clock	F <sub>SUB</sub> = 32.768KHz <sup>Note4</sup>	Square	-	65	80	uA	
					Resonator	-	65	80		
			I <sub>DD2</sub>	Sleep mode	High-speed on-chip oscillator	F <sub>HOCO</sub> = 64MHz, F <sub>IH</sub> = 64MHz <sup>Note3</sup>	-	1.7	3.6	mA
						F <sub>HOCO</sub> = 48MHz, F <sub>IH</sub> = 48MHz <sup>Note3</sup>	-	1.4	2.8	
					F <sub>HOCO</sub> = 8MHz, F <sub>IH</sub> = 8MHz <sup>Note3</sup>	-	0.5	0.8		
		high-speed main clock		F <sub>MX</sub> = 20MHz <sup>Note2</sup>	Square	-	0.7	1.4	mA	
					Resonator	-	0.7	1.4		
		high-speed SUB clock		F <sub>SUB</sub> = 32.768KHz <sup>Note5</sup>	Square	-	0.7	12.5	uA	
			Resonator		-	0.7	12.5			
		I <sub>DD3</sub> <sup>Note6</sup>	Deep Sleep mode <sup>Note7</sup>	T <sub>A</sub> = -40°C ~ 25°C V <sub>DD</sub> = 3.0V		-	0.45	0.9	uA	
	T <sub>A</sub> = -40°C ~ 85°C V <sub>DD</sub> = 3.0V			-	0.45	5.0				
	T <sub>A</sub> = -40°C ~ 105°C V <sub>DD</sub> = 3.0V			-	0.45	12				

Note1: Total current flowing into V<sub>DD</sub>, including the input leakage current flowing when the level of the input pin is fixed to V<sub>DD</sub> or V<sub>SS</sub>. The values of the TYP. column include the current of the CPU executing the multiplication instruction (I<sub>DD1</sub>), not including the peripheral operation current. The values below the MAX. column include the current of the CPU executing the multiplication instruction (I<sub>DD1</sub>) and the peripheral operation current. However, not including the current flowing into the A/D converter, LVD circuit, I/O port, and on-chip pull-up/pull-down resistors and the current flowing during data flash rewrite.

Note2: When high-speed on-chip oscillator and subsystem clock are stopped.

Note3: When high-speed system clock and subsystem clock are stopped.

Note4: When high-speed on-chip oscillator and high-speed system clock are stopped.

Note5: When high-speed on-chip oscillator and high-speed system clock are stopped. The current flowing into the RTC is included. However, not including the current flowing into the 12-bit interval timer and watchdog timer.

Note6: Not including the current flowing into the RTC, 12-bit interval timer, and watchdog timer.

Note7: Regarding the value for current to operate the subsystem clock in DeepSleep mode, refer to that in Sleep mode.

## Remark:

1.  $F_{IL}$ : Clock frequency of the low speed internal oscillator.
2.  $F_{SUB}$ : Sub system clock frequency (XT1 clock oscillation frequency).
3.  $F_{CLK}$ : Clock frequency of CPU/peripheral hardware.
4. Temperature condition of the TYP. value is  $T_A = 25^{\circ}\text{C}$ .
5. Low temperature specification value shall be guaranteed by the design, and low temperature conditions shall not be measured in mass production.

$(T_A = -40 \sim 105^\circ\text{C}, 2.0\text{V} \leq V_{DD} \leq 5.5\text{V}, V_{SS} = 0\text{V})$ 

Parameter	Symbol	Conditions	Min	Typ	Max	Unit	
Low-speed on-chip oscillator operating current	$I_{FIL}^{\text{Note1}}$	-	-	0.2	-	uA	
RTC operating current	$I_{RTC}^{\text{Note1,2,3}}$	-	-	0.04	-	uA	
15-bit interval timer operating current	$I_{IT}^{\text{Note1,2,4}}$	-	-	0.02	-	uA	
Watchdog timer operating current	$I_{WDT}^{\text{Note1,2,5}}$	$F_{IL} = 15\text{KHz}$	-	0.22	-	uA	
A/D operating current	$I_{ADC}^{\text{Note1,6}}$	ADC HS mode @64MHz	-	2.2	-	mA	
		ADC HS mode @4MHz	-	1.3	-	mA	
		ADC LC mode @24MHz	-	1.1	-	mA	
		ADC LC mode @4MHz	-	0.8	-	mA	
PGA operating current		Per PGA channel	-	480	700	uA	
CMP operating current	$I_{CMP}^{\text{Note1,9}}$	Per CMP channel	When the internal reference voltage is not in use	-	60	100	uA
			When the internal reference voltage is in use	-	80	140	uA
LVD operating current	$I_{LVD}^{\text{Note1,7}}$	-	-	0.08	-	uA	

Note1: Current flowing to  $V_{DD}$ .

Note2: When high speed on-chip oscillator and high-speed system clock are stopped.

Note3: Current flowing only to the real-time clock (RTC) (excluding the operating current of the low-speed on-chip oscillator and the XT1 oscillator). The supply current of the microcontrollers is the sum of the values of either  $I_{DD1}$  or  $I_{DD2}$ , and  $I_{RTC}$ , when the real-time clock operates in operation mode or Sleep mode. When the low-speed on-chip oscillator is selected,  $I_{FIL}$  should be added.  $I_{DD2}$  subsystem clock operation includes the operational current of the real-time clock.

Note4: Current flowing only to the 15-bit interval timer (excluding the operating current of the low-speed on-chip oscillator and the XT1 oscillator). The supply current of the microcontrollers is the sum of the values of either  $I_{DD1}$  or  $I_{DD2}$ , and  $I_{IT}$ , when the 15-bit interval timer operates in operation mode or Sleep mode. When the low-speed on-chip oscillator is selected,  $I_{FIL}$  should be added.

Note5: Current flowing only to the watchdog timer (including the operating current of the low-speed on-chip oscillator).

Note6: Current flowing only to the A/D converter. The supply current of the microcontrollers is the sum of  $I_{DD1}$  or  $I_{DD2}$  and  $I_{ADC}$  when the A/D converter operates in an operation mode or the Sleep mode.

Note7: Current flowing only to the LVD circuit. The supply current of the microcontrollers is the sum of  $I_{DD1}$ ,  $I_{DD2}$  or  $I_{DD3}$  and  $I_{LVD}$  when the LVD circuit is in operation.

Note8: Current flowing only to the D/A converter. The supply current of the microcontrollers is the sum of  $I_{DD1}$  or  $I_{DD2}$  and  $I_{DAC}$  when the D/A converter operates in an operation mode or the Sleep mode.

Note9: Current flowing only to the comparator circuit. The supply current of the microcontrollers is the sum of  $I_{DD1}$ ,  $I_{DD2}$ , or  $I_{DD3}$  and  $I_{CMP}$  when the comparator circuit is in operation.

## Remark:

1.  $f_{IL}$ : Low-speed on-chip oscillator clock frequency
2. Temperature condition of the TYP. value is  $T_A = 25^\circ\text{C}$ .
3. Low temperature specification value shall be guaranteed by the design, and low temperature conditions shall not be measured in mass production.

## 6.6 AC Characteristics

( $T_A = -40 \sim 105^\circ\text{C}$ ,  $2.0\text{V} \leq V_{DD} \leq 5.5\text{V}$ ,  $V_{SS} = 0\text{V}$ )

Items	Symbol	Conditions		Min	Typ	Max	Unit
Instruction cycle (minimum instruction execution time)	$T_{CY}$	Main system clock ( $F_{MAIN}$ ) operation	$2.0\text{V} \leq V_{DD} \leq 5.5\text{V}$	0.015625	-	1	us
		Subsystem clock ( $F_{SUB}$ ) operation	$2.0\text{V} \leq V_{DD} \leq 5.5\text{V}$	28.5	30.5	31.3	us
External system clock frequency	$F_{EX}$	$2.0\text{V} \leq V_{DD} \leq 5.5\text{V}$		1.0	-	20.0	MHz
	$F_{EXS}$	$2.0\text{V} \leq V_{DD} \leq 5.5\text{V}$		32.0	-	35.0	KHz
External system clock input high-level width, low-level width	$T_{EXH}$ $T_{EXL}$	$2.0\text{V} \leq V_{DD} \leq 5.5\text{V}$		24	-	-	ns
	$T_{EXHS}$ $T_{EXLS}$	$2.0\text{V} \leq V_{DD} \leq 5.5\text{V}$		13.7	-	-	us
T100 ~ T103, input high-level width, low- level width	$T_{TIH}$ $T_{TIL}$	$2.0\text{V} \leq V_{DD} \leq 5.5\text{V}$		$1/F_{MCK}$ +10	-	-	ns
TO00 ~ TO03, TO10 ~ T103, output frequency	$F_{TO}$	$4.0\text{V} \leq V_{DD} \leq 5.5\text{V}$		-	-	16	MHz
		$2.4\text{V} \leq V_{DD} < 4.0\text{V}$		-	-	8	MHz
		$2.0\text{V} \leq V_{DD} < 2.4\text{V}$		-	-	4	MHz
CLKBUZ0, CLKBUZ1 output frequency	$F_{PCL}$	$4.0\text{V} \leq V_{DD} \leq 5.5\text{V}$		-	-	16	MHz
		$2.4\text{V} \leq V_{DD} < 4.0\text{V}$		-	-	8	MHz
		$2.0\text{V} \leq V_{DD} < 2.4\text{V}$		-	-	4	MHz
Interrupt input high- level width, low-level width	$T_{INTH}$ $T_{INTL}$	INTP0 ~ INTP11	$2.0\text{V} \leq V_{DD} \leq 5.5\text{V}$	1	-	-	us
RESETB low-level width	$T_{RSL}$	-		10	-	-	us

Remark:

1.  $F_{MCK}$ : Timer4 operation clock frequency
2. Low temperature specification value shall be guaranteed by the design, and low temperature conditions shall not be measured in mass production.

## 6.7 Peripheral Functions Characteristics

### 6.7.1 Serial Communication Interface

(1) UART mode

( $T_A = -40 \sim 85^\circ\text{C}$ ,  $2.0\text{V} \leq V_{DD} \leq 5.5\text{V}$ ,  $V_{SS} = 0\text{V}$ )

Parameter	Conditions		Spec		Unit
			Min	Max	
Transfer rate	$2.0\text{V} \leq V_{DD} \leq 5.5\text{V}$	-	-	$F_{MCK} / 6$	bps
		Theoretical value of the maximum transfer rate $F_{MCK} = F_{CLK}$	-	10.6	Mbps

Remark: It is guaranteed by the design and not tested in mass production.

( $T_A = 85 \sim 105^\circ\text{C}$ ,  $2.0\text{V} \leq V_{DD} \leq 5.5\text{V}$ ,  $V_{SS} = 0\text{V}$ )

Parameter	Conditions		Spec		Unit
			Min	Max	
Transfer rate	$2.0\text{V} \leq V_{DD} \leq 5.5\text{V}$	-	-	$F_{MCK} / 12$	bps
		Theoretical value of the maximum transfer rate $F_{MCK} = F_{CLK}$	-	5.3	Mbps

Remark: It is guaranteed by the design and not tested in mass production.

(2) 3-wire serial I/O(SSPI) (master mode, internal clock output)

 $(T_A = -40 \sim 105^\circ\text{C}, 2.0\text{V} \leq V_{DD} \leq 5.5\text{V}, V_{SS} = 0\text{V})$ 

Parameter	Symbol	Conditions	-40 ~ 85°C		85 ~ 105°C		Unit	
			Min	Max	Min	Max		
SCLKp cycle time	$T_{KCY1}$	$T_{KCY1} \geq 2/F_{CLK}$	$4.0\text{V} \leq V_{DD} \leq 5.5\text{V}$	31.25	-	62.5	-	ns
			$2.7\text{V} \leq V_{DD} \leq 5.5\text{V}$	41.67	-	83.3	-	ns
			$2.4\text{V} \leq V_{DD} \leq 5.5\text{V}$	65	-	125	-	ns
			$2.0\text{V} \leq V_{DD} \leq 5.5\text{V}$	125	-	250	-	ns
SCLKp high-/low-level width	$T_{KH1}$ $T_{KL1}$	$4.0\text{V} \leq V_{DD} \leq 5.5\text{V}$	$T_{KCY1}/2-$ 4	-	$T_{KCY1}/2-$ 7	-	ns	
		$2.7\text{V} \leq V_{DD} \leq 5.5\text{V}$	$T_{KCY1}/2-$ 5	-	$T_{KCY1}/2-$ 10	-	ns	
		$2.4\text{V} \leq V_{DD} \leq 5.5\text{V}$	$T_{KCY1}/2-$ 10	-	$T_{KCY1}/2-$ 20	-	ns	
		$2.0\text{V} \leq V_{DD} \leq 5.5\text{V}$	$T_{KCY1}/2-$ 19	-	$T_{KCY1}/2-$ 38	-	ns	
SDIp setup time (to SCLKp↑)	$T_{SIK1}$	$4.0\text{V} \leq V_{DD} \leq 5.5\text{V}$	12	-	23	-	ns	
		$2.7\text{V} \leq V_{DD} \leq 5.5\text{V}$	17	-	33	-	ns	
		$2.4\text{V} \leq V_{DD} \leq 5.5\text{V}$	20	-	38	-	ns	
		$2.0\text{V} \leq V_{DD} \leq 5.5\text{V}$	28	-	55	-	ns	
SDIp hold time (from CLKp↑)	$T_{KSI1}$	$2.0\text{V} \leq V_{DD} \leq 5.5\text{V}$	5	-	10	-	ns	
SCLKp↓→SD Op Delay time	$T_{KSO1}$	$2.0\text{V} \leq V_{DD} \leq 5.5\text{V}$ $C=20\text{pF}^{\text{Note1}}$	-	5	-	10	ns	

Note1: C is the load capacitance of the SCLKp and SDOp output lines.

Caution: Select the normal input buffer for the SDIp pin and the normal output mode for the SDOp pin and SCLKp pin by using port input mode register g (PIMg) and port output mode register g (POMg).

Remark: It is guaranteed by the design and not tested in mass production.



## (3) 3-wire serial I/O(SSPI) (slave mode, external clock input)

 ( $T_A = -40 \sim 105^\circ\text{C}$ ,  $2.0\text{V} \leq V_{DD} \leq 5.5\text{V}$ ,  $V_{SS} = 0\text{V}$ )

Parameter	Symbol	Conditions	-40 ~ 85°C		85 ~ 105°C		Unit	
			Min	Max	Min	Max		
SCLKp cycle time	$T_{KCY2}$	$4.0\text{V} \leq V_{DD} \leq 5.5\text{V}$	$20\text{MHz} < F_{MCK}$	$8/F_{MCK}$	-	$16/F_{MCK}$	-	ns
		$5.5\text{V}$	$F_{MCK} \leq 20\text{MHz}$	$6/F_{MCK}$	-	$12/F_{MCK}$	-	ns
		$2.7\text{V} \leq V_{DD} \leq 5.5\text{V}$	$16\text{MHz} < F_{MCK}$	$8/F_{MCK}$	-	$16/F_{MCK}$	-	ns
		$5.5\text{V}$	$F_{MCK} \leq 16\text{MHz}$	$6/F_{MCK}$	-	$12/F_{MCK}$	-	ns
		$2.4\text{V} \leq V_{DD} \leq 5.5\text{V}$		$6/F_{MCK}$ and $\geq 500$	-	$12/F_{MCK}$ and $\geq 1000$	-	ns
		$2.0\text{V} \leq V_{DD} \leq 5.5\text{V}$		$6/F_{MCK}$ and $\geq 750$	-	$12/F_{MCK}$ and $\geq 1500$	-	ns
SCLKp high-/low-level width	$T_{KH2}$ $T_{KL2}$	$4.0\text{V} \leq V_{DD} \leq 5.5\text{V}$		$T_{KCY1}/2-7$	-	$T_{KCY1}/2-14$	-	ns
		$2.7\text{V} \leq V_{DD} \leq 5.5\text{V}$		$T_{KCY1}/2-8$	-	$T_{KCY1}/2-16$	-	ns
		$2.0\text{V} \leq V_{DD} \leq 5.5\text{V}$		$T_{KCY1}/2-18$	-	$T_{KCY1}/2-36$	-	ns
SDIp setup time (to SCLKp↑)	$T_{SIK2}$	$2.7\text{V} \leq V_{DD} \leq 5.5\text{V}$		$1/F_{MCK}+20$	-	$1/F_{MCK}+40$	-	ns
		$2.0\text{V} \leq V_{DD} \leq 5.5\text{V}$		$1/F_{MCK}+30$	-	$1/F_{MCK}+60$	-	ns
SDIp hold time (from SCLKp↑)	$T_{KSI2}$	$2.0\text{V} \leq V_{DD} \leq 5.5\text{V}$		$1/F_{MCK}+31$	-	$1/F_{MCK}+62$	-	ns
SCLKp↓→SDOp Delay time	$T_{KSO2}$	$2.7\text{V} \leq V_{DD} \leq 5.5\text{V}$ $C=30\text{pF}$ <sup>Note1</sup>		-	$2/F_{MCK}+$ 44	-	$2/F_{MCK}+$ 66	ns
		$2.4\text{V} \leq V_{DD} \leq 5.5\text{V}$ $C=30\text{pF}$ <sup>Note1</sup>		-	$2/F_{MCK}+$ 75	-	$2/F_{MCK}+$ 113	ns
		$2.0\text{V} \leq V_{DD} \leq 5.5\text{V}$ $C=30\text{pF}$ <sup>Note1</sup>		-	$2/F_{MCK}+$ 100	-	$2/F_{MCK}+$ 150	ns

Note1: C is the load capacitance of the SCLKp and SDOp output lines.

Caution: Select the normal input buffer for the SDIp pin and the normal output mode for the SDOp pin and SCLKp pin by using port input mode register g (PIMg) and port output mode register g (POMg).

Remark: It is guaranteed by the design and not tested in mass production.

(4) 4-wire serial I/O(SPI) (slave mode, external clock input)

 ( $T_A = -40 \sim 105^\circ\text{C}$ ,  $2.0\text{V} \leq V_{DD} \leq 5.5\text{V}$ ,  $V_{SS} = 0\text{V}$ )

Parameter	Symbol	Conditions	-40 ~ 85°C		85 ~ 105°C		Unit	
			Min	Max	Min	Max		
SSI00 setup time	$T_{SSIK}$	DAPmn=0	$2.7\text{V} \leq V_{DD} \leq 5.5\text{V}$	120	-	240	-	ns
			$2.0\text{V} \leq V_{DD} \leq 5.5\text{V}$	200	-	400	-	ns
		DAPmn=1	$2.7\text{V} \leq V_{DD} \leq 5.5\text{V}$	$1/F_{MCK} + 120$	-	$1/F_{MCK} + 240$	-	ns
			$2.0\text{V} \leq V_{DD} \leq 5.5\text{V}$	$1/F_{MCK} + 200$	-	$1/F_{MCK} + 400$	-	ns
SSI00 hold time	$T_{KSSI}$	DAPmn=0	$2.7\text{V} \leq V_{DD} \leq 5.5\text{V}$	$1/F_{MCK} + 120$	-	$1/F_{MCK} + 240$	-	ns
			$2.0\text{V} \leq V_{DD} \leq 5.5\text{V}$	$1/F_{MCK} + 200$	-	$1/F_{MCK} + 400$	-	ns
		DAPmn=1	$2.7\text{V} \leq V_{DD} \leq 5.5\text{V}$	120	-	240	-	ns
			$2.0\text{V} \leq V_{DD} \leq 5.5\text{V}$	200	-	400	-	ns

Caution: Select the normal input buffer for the SDIp pin and the normal output mode for the SDOp pin and SCLKp pin by using port input mode register g (PIMg) and port output mode register g (POMg).

Remark: It is guaranteed by the design and not tested in mass production.

## 6.7.2 Serial Interface IICA

### (1) I<sup>2</sup>C standard mode

(T<sub>A</sub>= -40~105°C, 2.0V ≤ V<sub>DD</sub> ≤ 5.5V, V<sub>SS</sub>=0V)

Parameter	Symbol	Conditions	Spec		Unit
			Min	Max	
SCLA0 clock frequency	F <sub>SCL</sub>	Standard mode: F <sub>CLK</sub> ≥ 1MHz	-	100	KHz
Setup time of restart condition	T <sub>SU: STA</sub>	-	4.7	-	us
Hold time <sup>Note1</sup>	T <sub>HD: STA</sub>	-	4.0	-	us
Hold time when SCLA0 = "L"	T <sub>LOW</sub>	-	4.7	-	us
Hold time when SCLA0 = "H"	T <sub>HIGH</sub>	-	4.0	-	us
Data setup time (reception)	T <sub>SU: DAT</sub>	-	250	-	ns
Data hold time (transmission) <sup>Note2</sup>	T <sub>HD: DAT</sub>	-	0	3.45	us
Setup time of stop condition	T <sub>SU: STO</sub>	-	4.0	-	us
Bus-free time	T <sub>BUF</sub>	-	4.7	-	us

Note1: The first clock pulse is generated after this period when the start/restart condition is detected.

Note2: The maximum value (MAX.) of T<sub>HD: DAT</sub> is during normal transfer and a wait state is inserted in the ACK (acknowledge) timing.

Remark:

- The maximum value of C<sub>b</sub> (communication line capacitance) and the value of R<sub>b</sub> (communication line pull-up resistor) at that time in each mode are as follows.  
Standard mode: C<sub>b</sub>=400pF, R<sub>b</sub>=2.7kΩ
- It is guaranteed by the design and not tested in mass production.

### (2) I<sup>2</sup>C fast mode

(T<sub>A</sub>= -40~105°C, 2.0V ≤ V<sub>DD</sub> ≤ 5.5V, V<sub>SS</sub>=0V)

Parameter	Symbol	Conditions	Spec		Unit
			Min	Max	
SCLA0 clock frequency	F <sub>SCL</sub>	Fast mode: F <sub>CLK</sub> ≥ 3.5MHz	-	400	KHz
Setup time of restart condition	T <sub>SU: STA</sub>	-	0.6	-	us
Hold time <sup>Note1</sup>	T <sub>HD: STA</sub>	-	0.6	-	us
Hold time when SCLA0 = "L"	T <sub>LOW</sub>	-	1.3	-	us
Hold time when SCLA0 = "H"	T <sub>HIGH</sub>	-	0.6	-	us
Data setup time (reception)	T <sub>SU: DAT</sub>	-	100	-	ns
Data hold time (transmission) <sup>Note2</sup>	T <sub>HD: DAT</sub>	-	0	0.9	us
Setup time of stop condition	T <sub>SU: STO</sub>	-	0.6	-	us
Bus-free time	T <sub>BUF</sub>	-	1.3	-	us

Note1: The first clock pulse is generated after this period when the start/restart condition is detected.

Note2: The maximum value (MAX.) of T<sub>HD: DAT</sub> is during normal transfer and a wait state is inserted in the ACK (acknowledge) timing.

## Remark:

1. The maximum value of  $C_b$  (communication line capacitance) and the value of  $R_b$  (communication line pull-up resistor) at that time in each mode are as follows.  
Fast mode:  $C_b=320\text{pF}$ ,  $R_b=1.1\text{k}\Omega$
2. It is guaranteed by the design and not tested in mass production.

(3) I<sup>2</sup>C fast mode plus

 ( $T_A = -40 \sim 105^\circ\text{C}$ ,  $2.0\text{V} \leq V_{DD} \leq 5.5\text{V}$ ,  $V_{SS} = 0\text{V}$ )

Parameter	Symbol	Conditions	Spec		Unit
			Min	Max	
SCLA0 clock frequency	F <sub>SCL</sub>	Fast mode plus: F <sub>CLK</sub> ≥ 10MHz	-	1000	KHz
Setup time of restart condition	T <sub>SU: STA</sub>	-	0.26	-	us
Hold time <sup>Note1</sup>	T <sub>HD: STA</sub>	-	0.26	-	us
Hold time when SCLA0 = "L"	T <sub>LOW</sub>	-	0.5	-	us
Hold time when SCLA0 = "H"	T <sub>HIGH</sub>	-	0.26	-	us
Data setup time (reception)	T <sub>SU: DAT</sub>	-	50	-	ns
Data hold time (transmission) <sup>Note2</sup>	T <sub>HD: DAT</sub>	-	0	0.45	us
Setup time of stop condition	T <sub>SU: STO</sub>	-	0.26	-	us
Bus-free time	T <sub>BUF</sub>	-	0.5	-	us

Note1: The first clock pulse is generated after this period when the start/restart condition is detected.

Note2: The maximum value (MAX.) of T<sub>HD: DAT</sub> is during normal transfer and a wait state is inserted in the ACK (acknowledge) timing.

Remark:

- The maximum value of C<sub>b</sub> (communication line capacitance) and the value of R<sub>b</sub> (communication line pull-up resistor) at that time in each mode are as follows.  
Fast mode plus: C<sub>b</sub>=120pF, R<sub>b</sub>=1.1kΩ
- It is guaranteed by the design and not tested in mass production.

## 6.8 Analog Characteristics

### 6.8.1 A/D Converter Characteristics

Classification of A/D converter characteristics

Input channel	Reference Voltage	Reference voltage(+)=AV <sub>REFP</sub> Reference voltage(-)=AV <sub>REFM</sub>	Reference voltage(+)=V <sub>DD</sub> Reference voltage(-)=V <sub>SS</sub>
	ANI0~ANI14		
Internal reference voltage		Refer to 6.8.1(1)。	Refer to 6.8.1 (2)。
Temperature sensor output voltage			

- (1) When reference voltage(+)=AV<sub>REFP</sub>/ANI0, reference voltage(-)=AV<sub>REFM</sub>/ANI1  
 (T<sub>A</sub>= -40~105°C, 2.0V≤AV<sub>REFP</sub>≤V<sub>DD</sub>≤5.5V, V<sub>SS</sub>=0V, reference voltage(+)=AV<sub>REFP</sub>, reference voltage(-)=AV<sub>REFM</sub>=0V)

Item	Symbol	Conditions		Min	Typ	Max	Unit
resolution	RES	-		-	12	-	bit
Combined error <sup>Note1</sup>	ET	12-bit resolution	1.8V ≤ AV <sub>REFP</sub> ≤ 5.5V	-	3	-	LSB
Zero scale error <sup>Note1</sup>	E <sub>ZS</sub>	12-bit resolution	1.8V ≤ AV <sub>REFP</sub> ≤ 5.5V	-	0	-	LSB
Full scale error <sup>Note1</sup>	E <sub>FS</sub>	12-bit resolution	1.8V ≤ AV <sub>REFP</sub> ≤ 5.5V	-	0	-	LSB
Integral linearity error <sup>Note1</sup>	EL	12-bit resolution	1.8V ≤ AV <sub>REFP</sub> ≤ 5.5V	-1	-	1	LSB
Differential Linearity Error <sup>Note1</sup>	ED	12-bit resolution	1.8V ≤ AV <sub>REFP</sub> ≤ 5.5V	-1.5	-	1.5	LSB
Conversion time <sup>Note3</sup>	T <sub>CONV</sub>	12-bit resolution Conversion object: ANI2~ANI36	1.8V ≤ V <sub>DD</sub> ≤ 5.5V	45	-	-	1/F <sub>ADC</sub>
		12-bit resolution Conversion object: internal reference voltage, temperature sensor output voltage, PGA output voltage	1.8V ≤ V <sub>DD</sub> ≤ 5.5V	72	-	-	1/F <sub>ADC</sub>
External input resistors	R <sub>AIN</sub>	R <sub>AIN</sub> < (Ts / (F <sub>ADC</sub> × C <sub>ADC</sub> × ln(2 <sup>12+2</sup> )) - R <sub>ADC</sub> )		-	7.5 <sup>Note4</sup>	-	kΩ
Sampling switch resistance	R <sub>ADC</sub>	-		-	-	1.5	kΩ
Sample-and-hold capacitance	C <sub>ADC</sub>	-		-	2	-	pF
Analog input voltage	V <sub>AIN</sub>	ANI2~ANI14		0	-	AV <sub>REFP</sub>	V
		Internal reference voltage(1.8V≤V <sub>DD</sub> ≤5.5V)		V <sub>BGR</sub> <sup>Note2</sup>			V
		The output voltage of the temperature sensor (1.8V≤V <sub>DD</sub> ≤5.5V)		V <sub>TMPS</sub> <sup>Note2</sup>			V

Note1: Quantization error (±1/2 LSB) is not included.

Note2: Please refer to "6.8.2 Characteristics of Temperature Sensor/ Internal Reference Voltage".

Note3: F<sub>ADC</sub> is the operating frequency of AD, and the maximum operating frequency is 64MHz.

Note4: Low temperature specification value shall be guaranteed by the design, and low temperature conditions shall not be measured in mass production. TYP are the default sampling period Ts=13.5 and the conversion speed is calculated at F<sub>ADC</sub>=64MHz.

(2) When reference voltage (+)=V<sub>DD</sub>, reference voltage (-)=V<sub>SS</sub>

 (T<sub>A</sub>= -40~ 105°C, 2.0V ≤ V<sub>DD</sub> ≤ 5.5V, V<sub>SS</sub> =0V, reference voltage (+)=V<sub>DD</sub>, reference voltage (-)=V<sub>SS</sub>)

Item	Symbol	Conditions		Min	Typ	Max	Unit
resolution	RES	-		-	12	-	bit
Combined error <sup>Note1</sup>	ET	12-bit resolution	1.8V ≤ AV <sub>REFP</sub> ≤ 5.5V	-	6	-	LSB
Zero scale error <sup>Note1</sup>	E <sub>ZS</sub>	12-bit resolution	1.8V ≤ AV <sub>REFP</sub> ≤ 5.5V	-	0	-	LSB
Full scale error <sup>Note1</sup>	E <sub>FS</sub>	12-bit resolution	1.8V ≤ AV <sub>REFP</sub> ≤ 5.5V	-	0	-	LSB
Integral linearity error <sup>Note1</sup>	EL	12-bit resolution	1.8V ≤ AV <sub>REFP</sub> ≤ 5.5V	-2	-	2	LSB
Differential Linearity Error <sup>Note1</sup>	ED	12-bit resolution	1.8V ≤ AV <sub>REFP</sub> ≤ 5.5V	-3	-	3	LSB
Conversion time <sup>Note3</sup>	T <sub>CONV</sub>	12-bit resolution Conversion object: ANI0~ANI36	1.8V ≤ V <sub>DD</sub> ≤ 5.5V	45	-	-	1/F <sub>ADC</sub>
		12-bit resolution Conversion object: internal reference voltage, temperature sensor output voltage, PGA output voltage PGA输出电压	1.8V ≤ V <sub>DD</sub> ≤ 5.5V	72	-	-	1/F <sub>ADC</sub>
External input resistors	R <sub>AIN</sub>	R <sub>AIN</sub> < (Ts / (F <sub>ADC</sub> × C <sub>ADC</sub> × ln(2 <sup>12+2</sup> )) - R <sub>ADC</sub> )		-	7.5 <sup>Note4</sup>		kΩ
Sampling switch resistance	R <sub>ADC</sub>	-		-	-	1.5	kΩ
Sample-and-hold capacitance	C <sub>ADC</sub>	-		-	2	-	pF
Analog input voltage	V <sub>AIN</sub>	ANI0~ANI36		0	-	V <sub>DD</sub>	V
		内部基准电压 (1.8V ≤ V <sub>DD</sub> ≤ 5.5V)		V <sub>BGR</sub> <sup>Note2</sup>			V
		温度传感器的输出电压 (1.8V ≤ V <sub>DD</sub> ≤ 5.5V)		V <sub>TMPS</sub> <sup>Note2</sup>			V

Note1: Quantization error (±1/2 LSB) is not included.

Note2: Please refer to "6.8.2 Characteristics of Temperature Sensor/ Internal Reference Voltage".

 Note3: F<sub>ADC</sub> is the operating frequency of AD, and the maximum operating frequency is 48MHz.

 Note4: Low temperature specification value shall be guaranteed by the design, and low temperature conditions shall not be measured in mass production. TYP are the default sampling period T<sub>s</sub>=13.5 and the conversion speed is calculated at F<sub>ADC</sub>=64MHz.

## 6.8.2 Temperature Sensor Characteristics/Internal Reference Voltage Characteristic

( $T_A = -40 \sim 105^\circ\text{C}$ ,  $2.0\text{V} \leq V_{DD} \leq 5.5\text{V}$ ,  $V_{SS} = 0\text{V}$ )

Parameter	Symbol	Conditions	Min	Typ	Max	Unit
Temperature sensor output voltage	$V_{TMS25}$	$T_A = 25^\circ\text{C}$	-	1.09	-	V
Internal reference voltage	$V_{BGR}$	$T_A = -40 \sim -20^\circ\text{C}$	1.2 <sup>Note1</sup>	1.45	1.8 <sup>Note1</sup>	V
		$T_A = -20 \sim 10^\circ\text{C}$	1.25	1.45	1.75	V
		$T_A = 10 \sim 105^\circ\text{C}$	1.35	1.45	1.65	V
Temperature coefficient	$F_{VTMS}$	Temperature dependent on temperature sensor voltage	-	-3.5	-	mV/°C
Operation stabilization wait time	$T_{AMP}$	-	5	-	-	us

Remark: Low temperature specifications are guaranteed by the design, and low temperature conditions are not measured in mass production.

## 6.8.3 Comparator

( $T_A = -40 \sim 105^\circ\text{C}$ ,  $2.0\text{V} \leq V_{DD} \leq 5.5\text{V}$ ,  $V_{SS} = 0\text{V}$ )

Parameter	Symbol	Conditions	Min	Typ	Max	Unit	
Input offset voltage	$V_{OFFSET}$	-	-	$\pm 10$	$\pm 40$	mV	
Input voltage range	$V_{IN}$	-	0	-	$V_{DD}$	V	
Internal reference voltage deviation	$\Delta V_{IREF}$	CmRVM register value: 7FH ~ 80H(m = 0, 1)	-	-	$\pm 2$	LSB	
		Other than above	-	-	$\pm 1$	LSB	
Response Time	$T_{CR}, T_{CF}$	Input amplitude $\pm 100\text{mV}$	-	70	150	ns	
Operation stabilization Time <sup>Note1</sup>	$T_{CMP}$	CMPn=0->1	$V_{DD} = 3.3 \sim 5.5\text{V}$	-	-	1	us
			$V_{DD} = 2.0 \sim 3.3\text{V}$	-	-	3	
Reference voltage stabilization wait time	$T_{VR}$	CVRE=0->1 <sup>Note2</sup>	-	-	20	us	
Operation current	$I_{CMPDD}$	Refer to 6.5.2 Supply Current Characteristics					

Note1: Time taken until the comparator satisfies the DC/AC characteristics after the comparator operation enable signal is switched (CMPnEN = 0 → 1).

Note2: Enable comparator output (CnOE bit = 1; n = 0 to 1) after enabling operation of the internal reference voltage generator (by setting the CVREm bit to 1; m = 0 to 1) and waiting for the operation stabilization time to elapse.

Remark: Low temperature specification value shall be guaranteed by the design, and low temperature conditions shall not be measured in mass production.



## 6.8.4 Programmable Gain Amplifier PGA

( $T_A = -40 \sim 105^\circ\text{C}$ ,  $2.0\text{V} \leq V_{DD} \leq 5.5\text{V}$ ,  $V_{SS} = 0\text{V}$ )

Parameter	Symbol	Conditions		Min	Typ	Max	Unit
Input offset voltage	$V_{IOPGA}$	-		-	-	$\pm 10$	mV
Input voltage range	$V_{IPGA}$	-		0	-	$0.9 \times V_{DD} / \text{Gain}$	V
Output voltage range	$V_{IOHPGA}$	-		$0.93 \times V_{DD}$	-	-	V
	$V_{IOLPGA}$	-		-	-	$0.07 \times V_{DD}$	V
Gain error	EG	x4	-	-	-	$\pm 1$	%
		x8	-	-	-	$\pm 1$	%
		x10	-	-	-	$\pm 1$	%
		x12	-	-	-	$\pm 2$	%
		x14	-	-	-	$\pm 2$	%
		x16	-	-	-	$\pm 2$	%
		x32	-	-	-	$\pm 3$	%
Slew rate	$SR_{RPGA}$	Rising $V_{in} = 0.1V_{DD}/\text{gain}$ to $0.9V_{DD}/\text{gain}$ . 10 to 90% of output voltage amplitude	$4.0\text{V} \leq V_{DD} \leq 5.5\text{V}$ (Other than x32)	3.5	-	-	V/us
			$4.0\text{V} \leq V_{DD} \leq 5.5\text{V}$ (x32)	3.0	-	-	
			$2.0\text{V} \leq V_{DD} \leq 4.0\text{V}$	0.5	-	-	
	$SR_{FPGA}$	Falling $V_{in} = 0.1V_{DD}/\text{gain}$ to $0.9V_{DD}/\text{gain}$ . 90 to 10% of output voltage amplitude	$4.0\text{V} \leq V_{DD} \leq 5.5\text{V}$ (Other than x32)	3.5	-	-	
			$4.0\text{V} \leq V_{DD} \leq 5.5\text{V}$ (x32)	3.0	-	-	
			$2.0\text{V} \leq V_{DD} \leq 4.0\text{V}$	0.5	-	-	
Reference voltage stabilization wait time <sup>Note1</sup>	$T_{PGA}$	x4	-	-	-	5	us
		x8	-	-	-	5	us
		x10	-	-	-	5	us
		x12	-	-	-	10	us
		x14	-	-	-	10	us
		x16	-	-	-	10	us
		x32	-	-	-	10	us
Operation current	$I_{PGADD}$	Refer to 6.5.2 Supply Current Characteristics					

Note1: Time required until a state is entered where the DC and AC specifications of the PGA are satisfied after the PGA operation has been enabled ( $PGAEN = 1$ ).

Remark: Low temperature specification value shall be guaranteed by the design, and low temperature conditions shall not be measured in mass production.

## 6.8.5 POR Circuit Characteristics

( $T_A = -40 \sim 105^\circ\text{C}$ ,  $V_{SS} = 0\text{V}$ )

Parameter	Symbol	Conditions	Min	Typ	Max	Unit
Power on/down reset threshold	$V_{POR}$	Voltage threshold on $V_{DD}$ rising	-	1.50	2.0	V
	$V_{PDR}$	Voltage threshold on $V_{DD}$ falling	1.37	1.45	-	V
Minimum pulse width <sup>Note1</sup>	$T_{PW}$	-	300	-	-	us

Note1: Minimum time required for a POR reset when  $V_{DD}$  exceeds below  $V_{PDR}$ . This is also the minimum time required for a POR reset from when  $V_{DD}$  exceeds below 0.7V to when  $V_{DD}$  exceeds  $V_{POR}$  while STOP mode is entered or the main system clock is stopped through setting bit 0 (HIOSTOP) and bit7 (MSTOP) in the clock operation status control register (CSC).

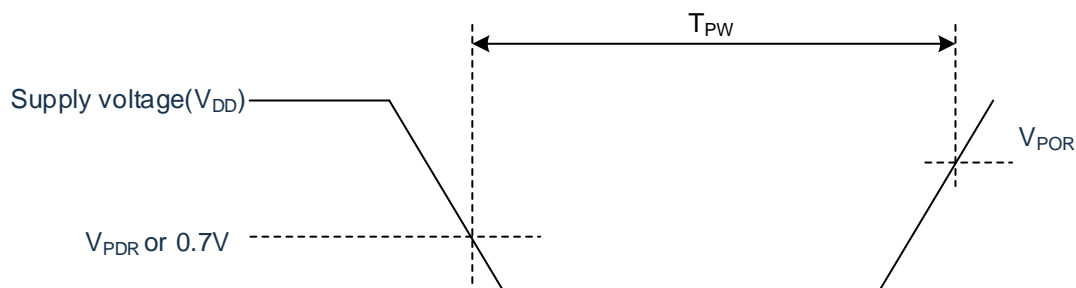

Remark: Low temperature specification value shall be guaranteed by the design, and low temperature conditions shall not be measured in mass production.

## 6.8.6 LVD Circuit Characteristics

(1) Reset Mode, Interrupt Mode

( $T_A = -40 \sim 105^\circ\text{C}$ ,  $V_{PDR} \leq V_{DD} \leq 5.5\text{V}$ ,  $V_{SS} = 0\text{V}$ )

Parameter	Symbol	Conditions	Min	Typ	Max	Unit
Voltage detection threshold	V <sub>LVD0</sub>	Rising edge	-	4.06	4.26	V
		Falling edge	3.78	3.98	-	V
	V <sub>LVD1</sub>	Rising edge	-	3.75	-	V
		Falling edge	-	3.67	-	V
	V <sub>LVD2</sub>	Rising edge	-	3.13	-	V
		Falling edge	-	3.06	-	V
	V <sub>LVD3</sub>	Rising edge	-	3.02	-	V
		Falling edge	-	2.96	-	V
	V <sub>LVD4</sub>	Rising edge	-	2.92	-	V
		Falling edge	-	2.86	-	V
	V <sub>LVD5</sub>	Rising edge	-	2.81	-	V
		Falling edge	-	2.75	-	V
	V <sub>LVD6</sub>	Rising edge	-	2.71	-	V
		Falling edge	-	2.65	-	V
	V <sub>LVD7</sub>	Rising edge	-	2.61	-	V
		Falling edge	-	2.55	-	V
	V <sub>LVD8</sub>	Rising edge	-	2.50	-	V
		Falling edge	-	2.45	-	V
	V <sub>LVD9</sub>	Rising edge	-	2.09	2.16	V
		Falling edge	1.97	2.04	-	V
Minimum pulse width	T <sub>LW</sub>	-	300	-	-	us
Detection delay time	-	-	-	-	300	us

Remark: Low temperature specification value shall be guaranteed by the design, and low temperature conditions shall not be measured in mass production.

## (2) Interrupt &amp; Reset Mode

 $(T_A = -40 \sim 105^\circ\text{C}, V_{PDR} \leq V_{DD} \leq 5.5\text{V}, V_{SS} = 0\text{V})$ 

Parameter	Symbol	Conditions	Min	Typ	Max	Unit	
Interrupt & Reset mode	VLVDB0	$V_{POC2}, V_{POC1}, V_{POC0} = 0, 0, 1$ , drop the reset voltage	1.78	1.84	-	V	
	VLVDB2	LVIS1, LVIS0=0, 1	Rise the reset release voltage	-	2.09	2.16	V
			Drop interrupt voltage	1.97	2.04	-	V
	VLVDB3	LVIS1, LVIS0=0, 0	Rise the reset release voltage	-	3.13	-	V
			Drop interrupt voltage	-	3.06	-	V
	VLVDC0	$V_{POC2}, V_{POC1}, V_{POC0} = 0, 1, 0$ , drop the reset voltage	-	2.45	-	V	
	VLVDC1	LVIS1, LVIS0=1, 0	Rise the reset release voltage	-	2.61	-	V
			Drop interrupt voltage	-	2.55	-	V
	VLVDC2	LVIS1, LVIS0=0, 1	Rise the reset release voltage	-	2.71	-	V
			Drop interrupt voltage	-	2.65	-	V
	VLVDC3	LVIS1, LVIS0=0, 0	Rise the reset release voltage	-	3.75	-	V
			Drop interrupt voltage	-	3.67	-	V
	VLVDD0	$V_{POC2}, V_{POC1}, V_{POC0} = 0, 1, 1$ , drop the reset voltage	-	2.75	-	V	
	VLVDD1	LVIS1, LVIS0=1, 0	Rise the reset release voltage	-	2.92	-	V
			Drop interrupt voltage	-	2.86	-	V
	VLVDD2	LVIS1, LVIS0=0, 1	Rise the reset release voltage	-	3.02	-	V
Drop interrupt voltage			-	2.96	-	V	
VLVDD3	LVIS1, LVIS0=0, 0	Rise the reset release voltage	-	4.06	4.26	V	
		Drop interrupt voltage	3.78	3.98	-	V	

Remark: Low temperature specification value shall be guaranteed by the design, and low temperature conditions shall not be measured in mass production.

## 6.8.7 Power Supply Voltage Rising Slope Characteristics

 $(T_A = -40 \sim 105^\circ\text{C}, V_{SS} = 0\text{V})$ 

Item	Symbol	Condition	Min	Typ	Max	Unit
Reset time	$T_{RESET}$	-	-	1	-	ms
The rising slope of the supply voltage	$SV_{DD}$	-	-	-	54	V/ms

Remark: Low temperature specification value shall be guaranteed by the design, and low temperature conditions shall not be measured in mass production.

## 6.9 Memory Characteristics

### 6.9.1 Flash Memory

( $T_A = -40 \sim 105^\circ\text{C}$ ,  $2.0\text{V} \leq V_{DD} \leq 5.5\text{V}$ ,  $V_{SS} = 0\text{V}$ )

Symbol	Parameter	Conditions	Min	Max	Unit
$T_{\text{PROG}}$	Word Program(32bit)	$T_A = -40 \sim 105^\circ\text{C}$	24	30	us
$T_{\text{ERASE}}$	Sector erase(512B)	$T_A = -40 \sim 105^\circ\text{C}$	4	5	ms
	Chip erase	$T_A = -40 \sim 105^\circ\text{C}$	20	40	ms
$N_{\text{END}}$	Endurance	$T_A = -40 \sim 105^\circ\text{C}$	100	-	kcycle
$T_{\text{RET}}$	Data retention	100 kcycle <sup>Note1</sup> at $T_A = 105^\circ\text{C}$	20	-	Years

Note1: Cycling performed over the whole temperature range.

Remark: Low temperature specification value shall be guaranteed by the design, and low temperature conditions shall not be measured in mass production.

### 6.9.2 RAM Memory

( $T_A = -40 \sim 105^\circ\text{C}$ ,  $2.0\text{V} \leq V_{DD} \leq 5.5\text{V}$ ,  $V_{SS} = 0\text{V}$ )

Symbol	Parameter	Conditions	Min	Max	Unit
$V_{\text{RAMHOLD}}$	RAM holds voltage	$T_A = -40 \sim 105^\circ\text{C}$	0.8	-	V

Remark: Low temperature specification value shall be guaranteed by the design, and low temperature conditions shall not be measured in mass production.

## 6.10 Electrical Sensitivity Characteristics

### 6.10.1 Electrostatic Discharge (ESD)

Symbol	Parameter	Conditions	Class
$V_{ESD(HBM)}$	Electrostatic discharge voltage (human body model)	$T_A = 25^{\circ}\text{C}$ JESD22-A114	3A

Remark: It is guaranteed by the design and not tested in mass production.

## 7 Package Drawings

### 7.1 TSSOP20(6.5x4.4mm, 0.65mm)

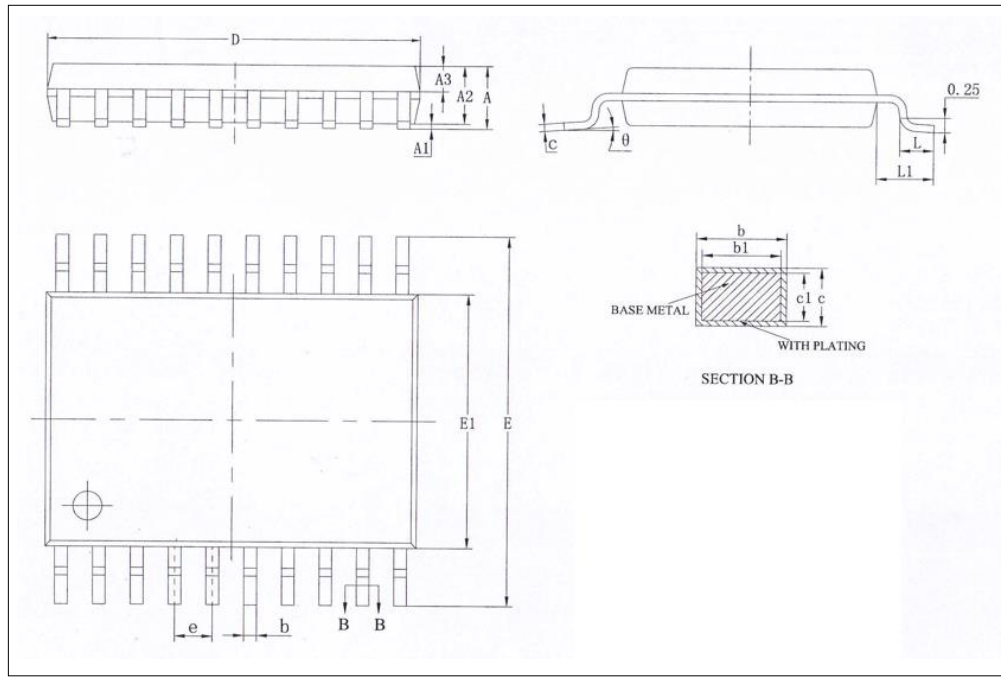

Symbol	Millimeter		
	Min	Nom	Max
A	-	-	1.20
A1	0.05	-	0.15
A2	0.80	1.00	1.05
A3	0.39	0.44	0.49
b	0.20	-	0.28
b1	0.19	0.22	0.25
c	0.13	-	0.17
c1	0.12	0.13	0.14
D	6.40	6.50	6.60
E1	4.30	4.40	4.50
E	6.20	6.40	6.60
e	0.65BSC		
L	0.45	0.60	0.75
L1	1.00REF		
$\theta$	0°	-	8°

## 7.2 QFN20(3x3mm, 0.4mm)

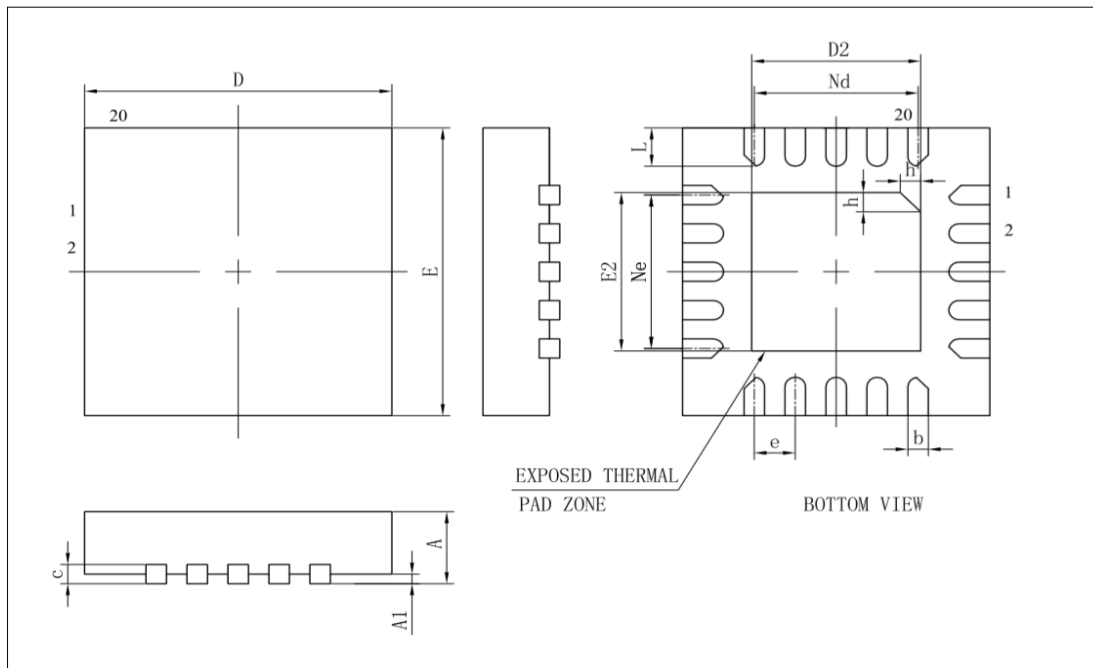

Symbol	Millimeter		
	Min	Nom	Max
A	0.70	0.75	0.80
A1	-	0.02	0.05
b	0.15	0.20	0.25
c	0.18	0.20	0.25
D	2.90	3.00	3.10
D2	1.55	1.65	1.75
e	0.40BSC		
Ne	1.60BSC		
Nd	1.60BSC		
E	2.90	3.00	3.10
E2	1.55	1.65	1.75
L	0.35	0.40	0.45
h	0.20	0.25	0.30



### 7.3 SSOP24(8.65x3.9mm, 0.635mm)

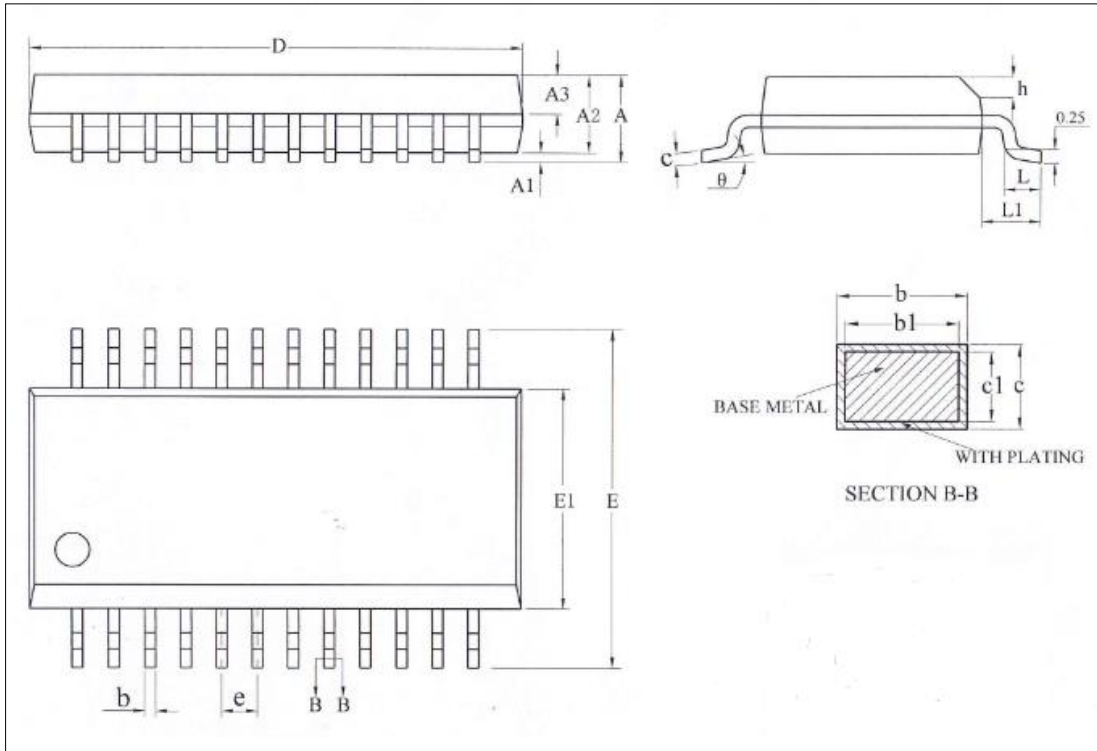

Symbol	Millimeter		
	Min	Nom	Max
A	-	-	1.75
A1	0.10	0.15	0.25
A2	1.30	1.40	1.50
A3	0.60	0.65	0.70
b	0.23	-	0.31
b1	0.22	0.25	0.28
c	0.20	-	0.24
c1	0.19	0.20	0.21
D	8.55	8.65	8.75
E	5.80	6.00	6.20
E1	3.80	3.90	4.00
e	0.635BSC		
h	0.30	-	0.50
L	0.50	-	0.80
L1	1.05REF		
θ	0°	-	8°

## 7.4 QFN24(4x4mm, 0.5mm)

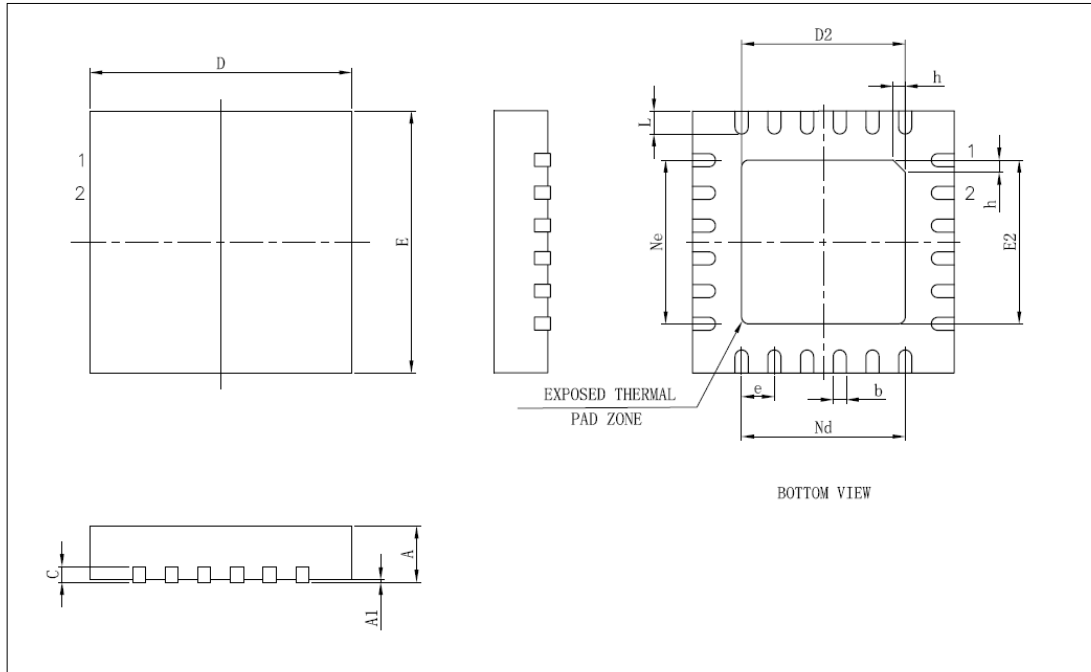

Symbol	Millimeter		
	Min	Nom	Max
A	0.70	0.75	0.80
A1	-	0.02	0.05
b	0.18	0.25	0.30
c	0.18	0.20	0.25
D	3.90	4.00	4.10
D2	2.40	2.50	2.60
e	0.50BSC		
Ne	2.50BSC		
Nd	2.50BSC		
E	3.90	4.00	4.10
E2	2.40	2.50	2.60
L	0.35	0.40	0.45
h	0.30	0.35	0.40

## 8 Revision History

Rev.	date	Description	
		Page/Chapter	Changes
1.0	2020.07.15	—	First Version Issue
1.5	2022.8.20	6.4.2, 6.5.2, 6.8.2	IDD1 operating mode MAX current modification (condition change) Add notes on low temperature conditions
		6.4.2, 6.8.2, 6.8.1	Update high and low temperature specifications Adjustment parameter name and specification value
1.5.1	2023.02.16	front cover	Modify cover content
		6.4.2	Modify 6.4.2 On-chip Oscillator Characteristics
		5.3, 5.4, 5.5.3	Content correction
1.5.2	2023.03.01	6.5.2	Modify deep sleep mode parameters