



BAT32G157 datasheet

ARM® Cortex®-M0+ based, ultra low power consumption 32-bit microcontroller

Built-in 256K byte Flash, rich simulation function, timer and various communication interfaces

Rev 1.8

Please be reminded about following CMS's policies on intellectual property

* Cmsemicon Limited(denoted as 'our company' for later use) has already applied for relative patents and entitled legal rights. Any patents related to CMS's MCU or other products is not authorized to use. Any individual, organization or company which infringes s our company's interlectual property rights will be forbidden and stopped by our company through any legal actions, and our company will claim the lost and required for compensation of any damage to the company.

* The name of Cmsemicon Limited and logo are both trademarks of our company.

* Our company preserve the rights to further elaborate on the improvements about products' function, reliability and design in this manual. However, our company is not responsible for any usage about this munal. The applications and their purposes in this manual are just for clarification, our company does not guarantee that these applications are feasible without further improvements and changes, and our company does not recommend any usage of the products in areas where people's safety is endangered during accident. Our company's products are not authorized to be used for life-saving or life support devices and systems.our company has the right to change or improve the product without any notification, for latest news, please visit our website: www.mcu.com.cn

Features :

- **Ultra-low power consumption operating environment:**
 - Power supply voltage range: 1.8V to 5.5V
 - Temperature range: -40°C to 105°C
 - Low power consumption mode: sleep mode, deep sleep mode
 - Operating power consumption: 120uA/MHz@64MHz
 - Power consumption in deep sleep mode: 0.7uA
 - Deep sleep mode+32.768K+RTC: 1.2uA
- **Core:**
 - ARM®32-bitCortex®-M0+ CPU
 - Working frequency: 32KHz~64MHz
- **Memory:**
 - 256KB Flash memory, with program and data storage shared
 - 2.5KB dedicated data Flash memory
 - 32KB SRAM memory with parity check
 - Support Remap function, you can choose to boot from Boot area, Code Flash area or RAM area
- **Power and reset management:**
 - Built-in power-on reset (POR) circuit
 - Built-in voltage detection (LVD) circuit (threshold voltage can be set)
- **Clock management:**
 - Built-in high-speed vibrator, accuracy ($\pm 1\%$). Can provide 1MHz~64MHz system clock and peripheral module operation clock
 - Built-in 15KHz low-speed oscillator
 - Built-in 2 PLL
 - Support 1MHz~20MHz external crystal oscillator
 - Support 32.768KHz external crystal oscillator
- **Multiplier/divider module:**
 - Multiplier: Support single cycle 32bit multiplication operation
 - Divider: Support 32bit signed integer division operation, only 8 CPU clock cycles to complete an operation
- **Enhanced DMA controller:**
 - Interrupt trigger start.
 - Transmission mode is selectable (normal transmission mode, repeated transmission mode, block transmission mode and chain transmission mode)
 - The transmission source/destination area is optional for the full address space range
- **Linkage controller:**
 - The event signals can be linked together to realize the linkage of peripheral functions.
 - 15 types of event input, 4 types of event trigger.
- **Abundant analog peripheral:**
 - 12-bit precision ADC converter, conversion rate 1.42MSPS, 35 external analog channels, internal optional PGA0 output as conversion channel, with temperature sensor, support single-channel conversion mode and multi-channel scan conversion mode Conversion range: 0 to positive reference voltage
 - Comparator (CMP), built-in two-channel comparator with hysteresis, optional input source, reference voltage can be external reference voltage or internal reference voltage
 - Programmable gain amplifier (PGA), built-in one channel PGA, can set 1/2/4/8/16/32/64/128 times gain, with external GND pin (can be used as differential mode), output with sample and hold Circuit to support offset voltage trimming
- **Input/output port:**
 - Number of I/O port: 44~58
 - Can switch between N-channel open drain and internal pull-up and pull-down
 - Built-in button interrupt detection function
 - Built-in clock output/buzzer output control circuit
- **Serial two-wire debugger (SWD)**
- **Abundant timer:**
 - 16-bit timer: 12 channels
 - 15-bit interval timer: 1
 - Real-time clock (RTC): 1 (with perpetual calendar, alarm clock function, and supports a wide range of clock correction)
 - Watchdog timer (WWDG) :1
 - SysTick timer
- **Abundant and flexible interface:**
 - 3-channel serial communication unit: each channel can be freely configured as a 1-channel standard UART, 2-channel SPI or 2-channel simple I2C
 - Standard SPI: 2 channel (support 8bit and16bit)
 - Standard I2C: 2 channel
 - SSIE: 1 channel

- **USB port:**
 - Compatible with USB 2.0 specification
 - Can be used as host controller or device controller
 - Support USB 2.0 full-speed and low-speed transmission
 - Support synchronous transmission, control transmission, batch transmission and interrupt transmission
 - Compatible with USB BC1.2
 - On-The-Go (OTG) feature
- **security function:**
 - Comply with relevant standards of IEC/UL 60730
- Abnormal storage space access error
- Support RAM parity check
- Support hardware CRC check
- Support important SFR protection to prevent misoperation
- 128-bit unique ID number
- Flash secondary protection in debug mode (level1: only the entire flash area can be erased, not read or write; level2: the emulator connection is invalid, and the flash operation is not possible)
- **Encapsulation:** Support multiple encapsulation of 48 Pin and 64 Pin

1 Overview

1.1 Introduction

Ultra-low power consumption BAT32G157 uses high-performance 32-bit RISC core of ARM®Cortex®-M0+, can work at a frequency of up to 64 MHz, and adopts high-speed embedded flash memory (SRAM max. 32KB, program/data flash memory max. 256KB). This product integrates multiple standard interfaces of I2C, SPI, UART, LIN, USB, and SSIE. Integrated 12bit A/D converter, temperature sensor, comparator, programmable gain amplifier. Among them, the 12bit A/D converter can collect external sensor signals, reducing system design costs. The temperature sensor integrated in the chip can realize real-time monitoring of the external ambient temperature. The internally integrated comparator of the chip can support both high-speed and low-speed operating modes. In the high-speed mode, it can support the control feedback of the high-speed motor, and in the low-speed mode, it can be used for battery monitoring. Integrated 12-channel 16bit timer module, and equipped with EPWM control circuit, combined with the timer can realize the control of one DC motor or two stepper motors.

BAT32G157 also has excellent low-power performance, supports two low-power modes of sleep and deep sleep, and is designed to be flexible. Its operating power consumption is 120uA/MHz@64MHz, and the power consumption is only 0.7uA in deep sleep mode, which is suitable for battery-powered low-power devices. At the same time, due to the integrated event linkage controller, direct connection between hardware modules can be realized without the intervention of the CPU, which is faster than using interrupt response, while reducing the frequency of CPU activity and prolonging the battery life.

These features make the BAT32G157 microcontroller series can be widely used in consumer civil products, such as household appliances, mobile devices, etc.

1.2 Product model list

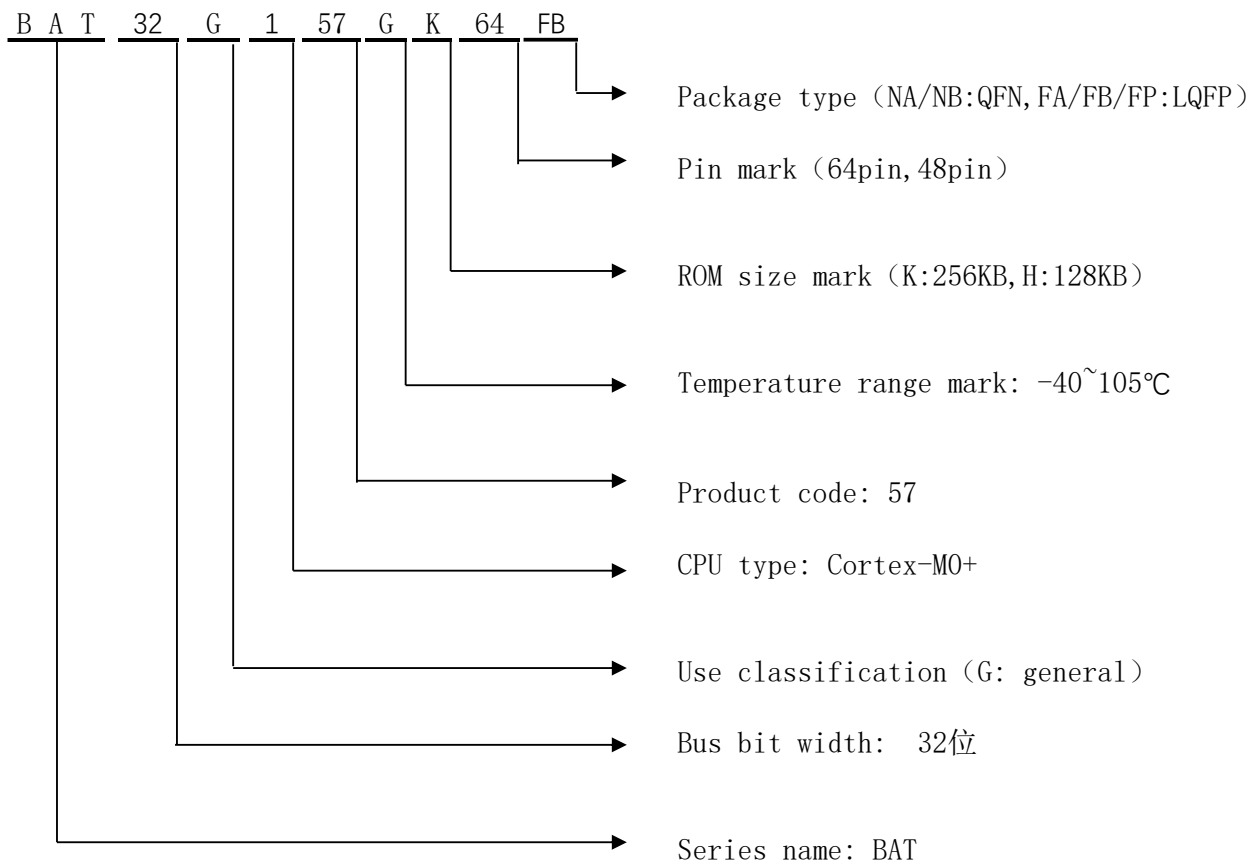

List of products of BAT32G157:

Number of Pin	Encapsulation	Product model
48 pin	48-pin plastic package LQFP (7×7mm, 0.5mm pitch)	BAT32G157GK48FA
64 pin	64-pin plastic package LQFP (7×7mm, 0.5mm pitch)	BAT32G157GK64FB

FLASH、SRAM capacity:

Flash memory	Special data Flash memory	SRAM	BAT32G157	
			48 pin	64 pin
256KB	2.5KB	32KB	BAT32G157GK48FA	BAT32G157GK64FB

1.3 Pin connection diagram (Top View)

1.3.1 48 pin product

- 48-pin plastic package LQFP (7×7mm, 0.5mm pitch)

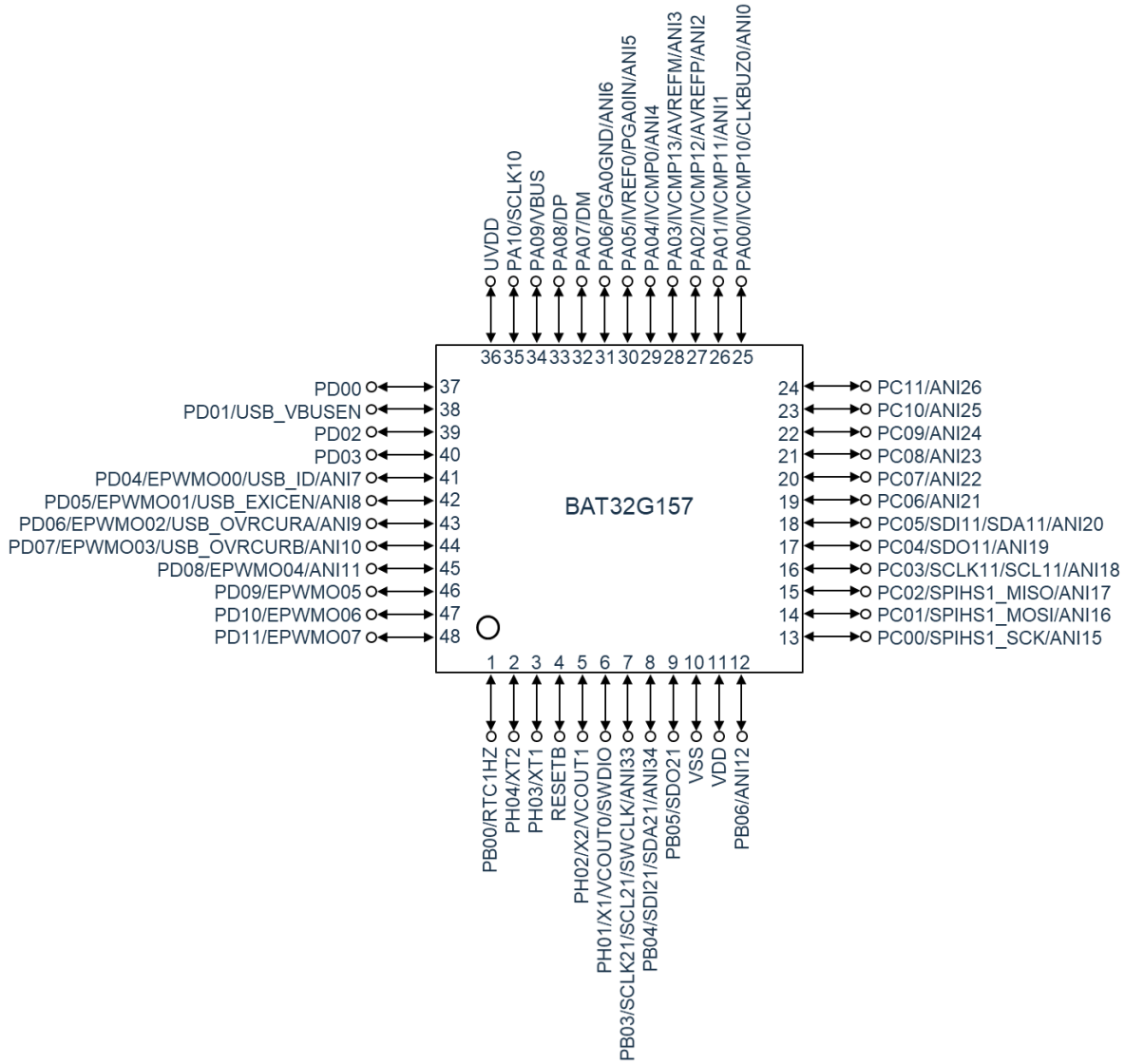

Note: The unmarked digital function support pins in the figure are configurable, see section 4.1 for details.

1.3.2 64 pin product

- 64-pin plastic package LQFP (7×7mm, 0.4mm pitch)

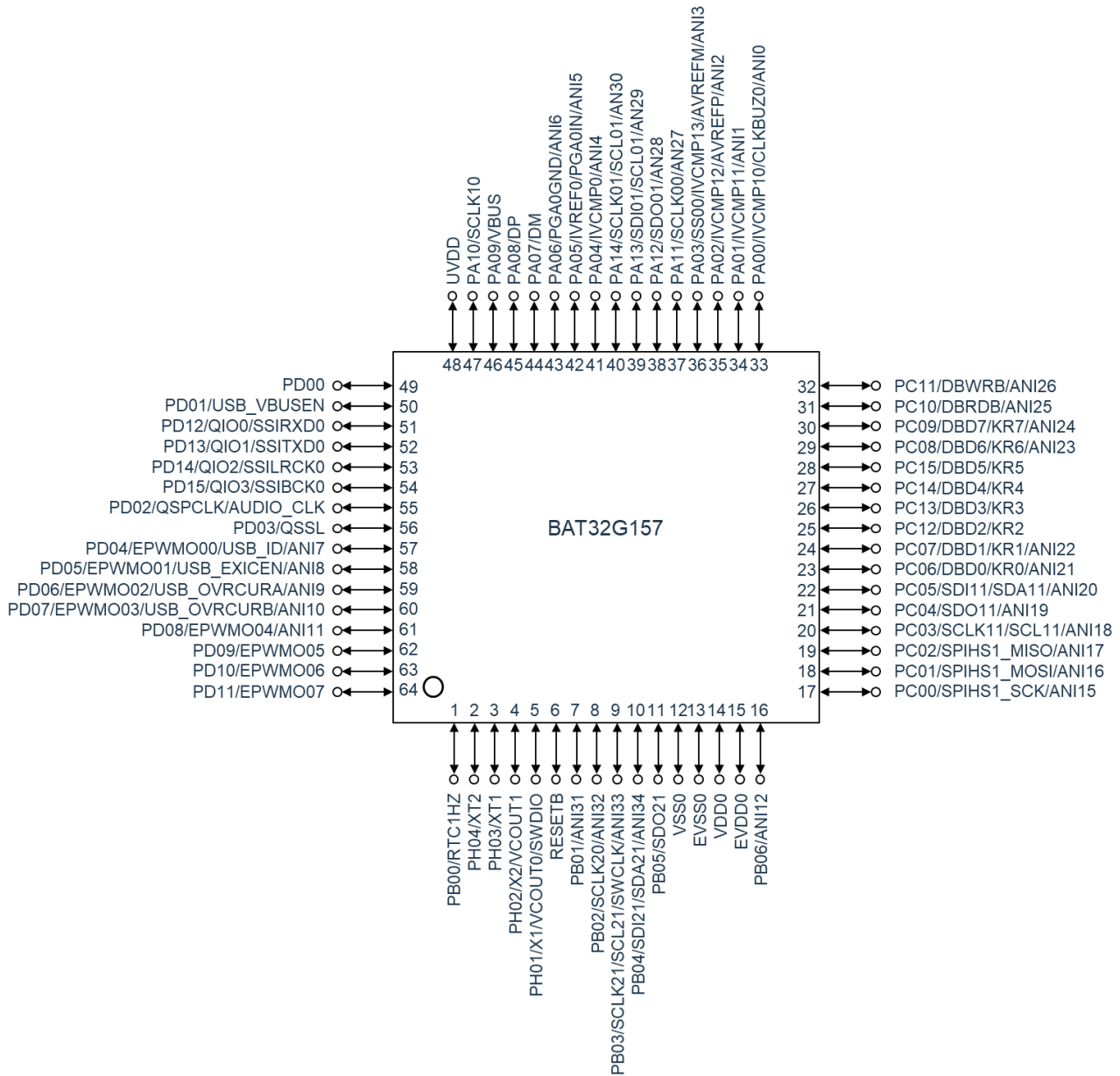

Note: The unmarked digital function support pins in the figure are configurable, see section 4.1 for details.

2 Product structure diagram

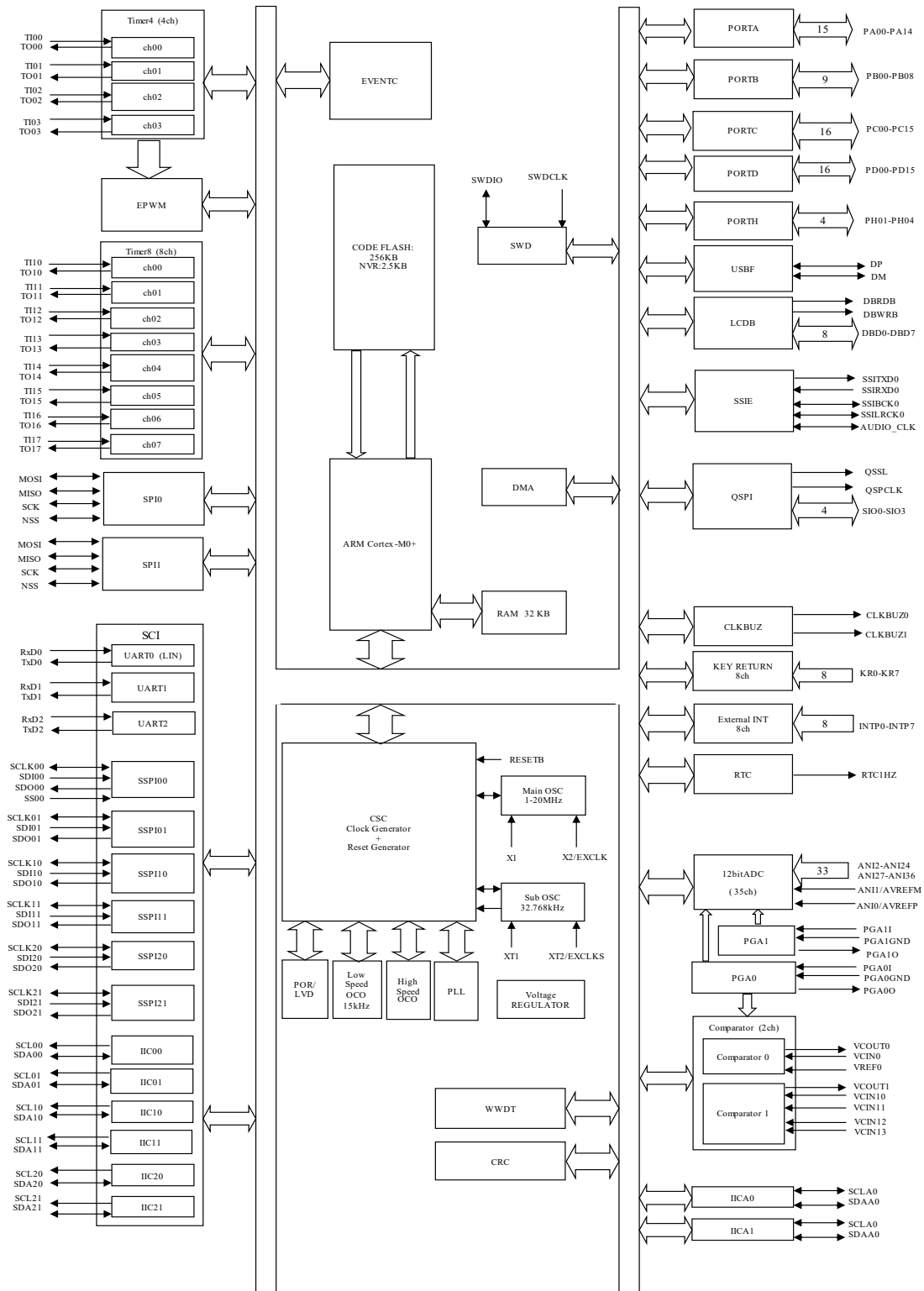

Note: The above is for 64 pin product. Some functions of products below 64 pin are not supported.

3 Memory mapping

#note:All green areas can be remapped to the mirrored area

FFFF_FFFFH	keep
E010_0000H	
E00F_FFFFH	M0+ dedicated peripheral area
E000_0000H	
	keep
4005_FFFFH	
4000_0000H	On-chip peripheral area
	keep
2000_7FFFH	RAM (32KB)
2000_0000H	
	keep
0850_0BFFFH	
	NVR
0850_0200H	
	keep
0803_FFFFH	Boot Area (4KB, 8KB, 16KB)
	User Flash (256KB)
0800_0000H	
	Mirror Area
0000_0000H	

4 Pin function

4.1 Port function

The functions of each port are shown in Table 4.1.1.

Table 4.1.1

Port name	Reuse function	Digital output function set register pxxcfg[3:0]	Digital input function set register xxxPCFG[5:0]	Whether the function is equipped	
				64LQFP	48LQFP
RESETB	RESETB	-	-	●	●
PA00	GPIO	00H	00H	●	●
	ANI0	00H	00H	●	●
	VCIN10	00H	00H	●	●
	CLKBUZ0	00H	00H	●	●
	Configurable digital functions	X (see table 4.1.3)	X (see table 4.1.3)	●	●
PA01	GPIO	00H	00H	●	●
	ANI1	00H	00H	●	●
	VCIN11	00H	00H	●	●
	Configurable digital functions	X (see table 4.1.3)	X (see table 4.1.3)	●	●
PA02	GPIO	00H	00H	●	●
	ANI2	00H	00H	●	●
	AVREFP	00H	00H	●	●
	VCIN12	00H	00H	●	●
	Configurable digital functions	X (see table 4.1.3)	X (see table 4.1.3)	●	●
PA03	GPIO	00H	00H	●	●
	ANI3	00H	00H	●	●
	AVREFM	00H	00H	●	●
	VCIN13	00H	00H	●	●
	SS00	00H	00H	●	●
	PGA_ADJOUT	00H	00H	●	●
	Configurable digital functions	X (see table 4.1.3)	X (see table 4.1.3)	●	●
PA04	GPIO	00H	00H	●	●
	ANI4	00H	00H	●	●
	VCIN0	00H	00H	●	●
	Configurable digital functions	X (see table 4.1.3)	X (see table 4.1.3)	●	●
PA05	GPIO	00H	00H	●	●
	ANI5	00H	00H	●	●
	VREF0	00H	00H	●	●
	PGA0IN	00H	00H	●	●
	Configurable digital functions	X (see table 4.1.3)	X (see table 4.1.3)	●	●
PA06	GPIO	00H	00H	●	●
	ANI6	00H	00H	●	●

	PGA0GND	00H	00H	●	●
	Configurable digital functions	X (see table 4.1.3)	X (see table 4.1.3)	●	●
PA07	GPIO	00H	00H	●	●
	USB_DM	00H	00H	●	●
	Configurable digital functions	X (see table 4.1.3)	X (see table 4.1.3)	●	●
PA08	GPIO	00H	00H	●	●
	USB_DP	00H	00H	●	●
	Configurable digital functions	X (see table 4.1.3)	X (see table 4.1.3)	●	●
PA09	GPIO	00H	00H	●	●
	USB_VBUS	00H	00H	●	●
	Configurable digital functions	X (see table 4.1.3)	X (see table 4.1.3)	●	●
PA10	GPIO	00H	00H	●	●
	SCLK10	00H	00H	●	●
	Configurable digital functions	X (see table 4.1.3)	X (see table 4.1.3)	●	●
PA11	GPIO	00H	00H	●	-
	ANI27	00H	00H	●	-
	SCLK00	00H	00H	●	-
	Configurable digital functions	X (see table 4.1.3)	X (see table 4.1.3)	●	-
PA12	GPIO	00H	00H	●	-
	ANI28	00H	00H	●	-
	SDO01	00H	00H	●	-
	Configurable digital functions	X (see table 4.1.3)	X (see table 4.1.3)	●	-
PA13	GPIO	00H	00H	●	-
	ANI29	00H	00H	●	-
	SDI01/SDA01	00H	00H	●	-
	Configurable digital functions	X (see table 4.1.3)	X (see table 4.1.3)	●	-
PA14	GPIO	00H	00H	●	-
	ANI30	00H	00H	●	-
	SCLK01/SCL01	00H	00H	●	-
	Configurable digital functions	X (see table 4.1.3)	X (see table 4.1.3)	●	-
PB00	GPIO	00H	00H	●	●
	RTC1HZ	00H	00H	●	●
	Configurable digital functions	X (see table 4.1.3)	X (see table 4.1.3)	●	●
PB01	GPIO	00H	00H	●	-
	ANI31	00H	00H	●	-
	Configurable digital functions	X (see table 4.1.3)	X (see table 4.1.3)	●	-
PB02	GPIO	00H	00H	●	-
	ANI32	00H	00H	●	-
	SCLK20	00H	00H	●	-
	Configurable digital functions	X (see table 4.1.3)	X (see table 4.1.3)	●	-

	functions				
PB03	GPIO	00H	00H	●	-
	ANI33	00H	00H	●	-
	SCLK21/SCL21	00H	00H	●	-
	SWCLK	00H	00H	●	-
	Configurable digital functions	X (see table 4.1.3)	X (see table 4.1.3)	●	-
PB04	GPIO	00H	00H	●	-
	ANI34	00H	00H	●	-
	SDI21/SDA21	00H	00H	●	-
	Configurable digital functions	X (see table 4.1.3)	X (see table 4.1.3)	●	-
PB06	GPIO	00H	00H	●	●
	ANI12	00H	00H	●	●
	Configurable digital functions	X (see table 4.1.3)	X (see table 4.1.3)	●	●
PC00	GPIO	00H	00H	●	●
	ANI15	00H	00H	●	●
	SPI1_SCK	00H	00H	●	●
	Configurable digital functions	X (see table 4.1.3)	X (see table 4.1.3)	●	●
PC01	GPIO	00H	00H	●	●
	ANI16	00H	00H	●	●
	SPI1_MOSI	00H	00H	●	●
	Configurable digital functions	X (see table 4.1.3)	X (see table 4.1.3)	●	●
PC02	GPIO	00H	00H	●	●
	ANI17	00H	00H	●	●
	SPI1_MISO	00H	00H	●	●
	Configurable digital functions	X (see table 4.1.3)	X (see table 4.1.3)	●	●
PC03	GPIO	00H	00H	●	●
	ANI18	00H	00H	●	●
	SPI0_SCK	00H	00H	●	●
	SCLK11/SCL11	00H	00H	●	●
	Configurable digital functions	X (see table 4.1.3)	X (see table 4.1.3)	●	●
PC04	GPIO	00H	00H	●	●
	ANI19	00H	00H	●	●
	SPI0_MOSI	00H	00H	●	●
	SDO11	00H	00H	●	●
	Configurable digital functions	X (see table 4.1.3)	X (see table 4.1.3)	●	●
PC05	GPIO	00H	00H	●	●
	ANI20	00H	00H	●	●
	SPI0_MISO	00H	00H	●	●
	SDI11/SDA11	00H	00H	●	●
	Configurable digital functions	X (see table 4.1.3)	X (see table 4.1.3)	●	●
PC06	GPIO	00H	00H	●	●

	ANI21	00H	00H	●	●
	KR0	00H	00H	●	●
	DBD0	00H	00H	●	-
	Configurable digital functions	X (see table 4.1.3)	X (see table 4.1.3)	●	-
PC07	GPIO	00H	00H	●	●
	ANI22	00H	00H	●	●
	KR1	00H	00H	●	●
	DBD1	00H	00H	●	-
	Configurable digital functions	X (see table 4.1.3)	X (see table 4.1.3)	●	●
PC08	GPIO	00H	00H	●	-
	ANI23	00H	00H	●	●
	KR6	00H	00H	●	●
	DBD6	00H	00H	●	-
	Configurable digital functions	X (see table 4.1.3)	X (see table 4.1.3)	●	●
PC09	GPIO	00H	00H	●	●
	ANI24	00H	00H	●	-
	KR7	00H	00H	●	●
	DBD7	00H	00H	●	-
	Configurable digital functions	X (see table 4.1.3)	X (see table 4.1.3)	●	●
PC10	GPIO	00H	00H	●	●
	ANI25	00H	00H	●	●
	DBRDB	00H	00H	●	-
	Configurable digital functions	X (see table 4.1.3)	X (see table 4.1.3)	●	●
PC11	GPIO	00H	00H	●	●
	ANI26	00H	00H	●	●
	Configurable digital functions	X (see table 4.1.3)	X (see table 4.1.3)	●	●
	KR4	00H	00H	●	-
	DBWRB	00H	00H	●	-
	Configurable digital functions	X (see table 4.1.3)	X (see table 4.1.3)	●	-
PC12	GPIO	00H	00H	●	-
	DBD2	00H	00H	●	-
	KR2	00H	00H	●	-
	Configurable digital functions	X (see table 4.1.3)	X (see table 4.1.3)	●	-
PC13	GPIO	00H	00H	●	-
	DBD3	00H	00H	●	-
	KR3	00H	00H	●	-
	Configurable digital functions	X (see table 4.1.3)	X (see table 4.1.3)	●	-
PC14	GPIO	00H	00H	●	-
	DBD4	00H	00H	●	-
	KR4	00H	00H	●	-
	Configurable digital functions	X (see table 4.1.3)	X (see table 4.1.3)	●	-

PC15	GPIO	00H	00H	●	-
	DBD5	00H	00H	●	-
	KR5	00H	00H	●	-
	Configurable digital functions	X (see table 4.1.3)	X (see table 4.1.3)	●	-
PD00	GPIO	00H	00H	●	●
	Configurable digital functions	X (see table 4.1.3)	X (see table 4.1.3)	●	●
PD01	GPIO	00H	00H	●	●
	USB_VBUSEN	00H	00H	●	●
	Configurable digital functions	X (see table 4.1.3)	X (see table 4.1.3)	●	●
PD02	GPIO	00H	00H	●	●
	QSPCLK	00H	00H	●	-
	SSIMCLK	00H	00H	●	-
	Configurable digital functions	X (see table 4.1.3)	X (see table 4.1.3)	●	●
PD03	GPIO	00H	00H	●	●
	QSSL	00H	00H	●	-
	Configurable digital functions	X (see table 4.1.3)	X (see table 4.1.3)	●	●
PD04	GPIO	00H	00H	●	●
	ANI7	00H	00H	●	●
	USB_ID	00H	00H	●	●
	EPWMO00	00H	00H	●	●
	Configurable digital functions	X (see table 4.1.3)	X (see table 4.1.3)	●	●
PD05	GPIO	00H	00H	●	●
	ANI8	00H	00H	●	●
	USB_EXICEN	00H	00H	●	●
	EPWMO01	00H	00H	●	●
	Configurable digital functions	X (see table 4.1.3)	X (see table 4.1.3)	●	●
PD06	GPIO	00H	00H	●	●
	ANI9	00H	00H	●	●
	USB_OVRCURA	00H	00H	●	●
	EPWMO02	00H	00H	●	●
	Configurable digital functions	X (see table 4.1.3)	X (see table 4.1.3)	●	●
PD07	GPIO	00H	00H	●	●
	ANI10	00H	00H	●	●
	USB_OVRCURB	00H	00H	●	●
	EPWMO03	00H	00H	●	●
	Configurable digital functions	X (see table 4.1.3)	X (see table 4.1.3)	●	●
PD08	GPIO	00H	00H	●	●
	ANI11	00H	00H	●	●
	EPWMO04	00H	00H	●	●
	Configurable digital functions	X (see table 4.1.3)	X (see table 4.1.3)	●	●
PD09	GPIO	00H	00H	●	●

	EPWMO05	00H	00H	●	●
	Configurable digital functions	X (see table 4.1.3)	X (see table 4.1.3)	●	●
PD10	GPIO	00H	00H	●	●
	EPWMO06	00H	00H	●	●
	Configurable digital functions	X (see table 4.1.3)	X (see table 4.1.3)	●	●
PD11	GPIO	00H	00H	●	●
	EPWMO07	00H	00H	●	●
	Configurable digital functions	X (see table 4.1.3)	X (see table 4.1.3)	●	●
PD12	GPIO	00H	00H	●	-
	QIO0	00H	00H	●	-
	SSIRXD0	00H	00H	●	-
	Configurable digital functions	X (see table 4.1.3)	X (see table 4.1.3)	●	-
PD13	GPIO	00H	00H	●	-
	QIO1	00H	00H	●	-
	SSITXD0	00H	00H	●	-
	Configurable digital functions	X (see table 4.1.3)	X (see table 4.1.3)	●	-
PD14	GPIO	00H	00H	●	-
	QIO2	00H	00H	●	-
	SSIRCK0/SSIFS	00H	00H	●	-
	Configurable digital functions	X (see table 4.1.3)	X (see table 4.1.3)	●	-
PD15	GPIO	00H	00H	●	-
	QIO3	00H	00H	●	-
	SSIBCK0	00H	00H	●	-
	Configurable digital functions	X (see table 4.1.3)	X (see table 4.1.3)	●	-
PH01	GPIO	00H	00H	●	●
	X1	00H	00H	●	●
	VCOUT0	00H	00H	●	●
	Configurable digital functions	X (see table 4.1.3)	X (see table 4.1.3)	●	●
PH02	GPIO	00H	00H	●	●
	X2	00H	00H	●	●
	EXCLK	00H	00H	●	●
	VCOUT1	00H	00H	●	●
	Configurable digital functions	X (see table 4.1.3)	X (see table 4.1.3)	●	●
PH03	GPIO	00H	00H	●	●
	XT1	00H	00H	●	●
	Configurable digital functions	X (see table 4.1.3)	X (see table 4.1.3)	●	●
PH04	GPIO	00H	00H	●	●
	XT2	00H	00H	●	●
	EXCLKS	00H	00H	●	●
	Configurable digital functions	X (see table 4.1.3)	X (see table 4.1.3)	●	●

VDD	Power supply	-	-	●	●
VSS	Ground	-	-	●	●
UVDD	Power supply	-	-	●	●
UVBUS	Power supply	-	-	●	●

The digital function configuration of this product is to divide the 60 ports into three groups, GRP0, GRP1, and GRP2, and redirect part of the functions within the group. Port grouping see table 4.1.2, digital function configuration see table 4.1.3.

In addition to the default multiplexing function of the 20 ports in GRP0, the multiplexing functions of channel 0~channel 3 of the universal timer TIMER4, serial interface UART0 and serial interface IICA0 can also be redirected arbitrarily.

In addition to the default multiplexing function of the 20 ports in GRP1, the multiplexing functions of channel 0~channel 3 of the universal timer TIMER8, serial interface UART1 and high-speed SPI serial port SPIHS0 can also be redirected arbitrarily.

In addition to the default multiplexing function of the 20 ports in GRP2, the multiplexing functions of channel 4~channel 7 of the universal timer TIMER8, serial interface UART2, serial interface IICA1 and buzzer output CLKBUZ1 can also be redirected arbitrarily.

Table 4.1.2 Port grouping

Serial number	GRP0	GRP1	GRP2
0	PB00	PC03	PB01
1	PH04	PC04	PB02
2	PH03	PC05	PB03
3	PH02	PC06	PB04
4	PH01	PC07	PB05
5	PC14	PC12	PB06
6	PC15	PC13	PB07
7	PC08	PA04	PB08
8	PC09	PA05	PC00
9	PC10	PA06	PC01
10	PC11	PA07	PC02
11	PA00	PA08	PA11
12	PA01	PA09	PA12
13	PA02	PA10	PA13
14	PA03	PD00	PA14
15	PD07	PD01	PD02
16	PD08	PD12	PD03
17	PD09	PD13	PD04
18	PD10	PD14	PD05
19	PD11	PD15	PD06

Table 4.1.3 List of digital function configuration (1/2 output function configuration)

Pin	Control register	Register configuration	Pin dual-purpose function
GRP0	PB00CFG/PH04CFG/PH03CFG/PH02CFG/ PH01CFG/PC14CFG/PC15CFG/PC08CFG/ PC09CFG/PC10CFG/PC11CFG/PA00CFG/ PA01CFG/PA02CFG/PC03CFG/PD07CFG/ PD08CFG/PD09CFG/PF10CFG/PD11CFG	4'h00	GPIO/default dual-purpose output
		4'h01	TO00
		4'h02	TO01
		4'h03	TO02
		4'h04	TO03
		4'h05	SDO00/TxD0
		Others	Prohibited to set
GRP1	PC03CFG/PC04CFG/PC05CFG/PC06CFG/ PC07CFG/PC12CFG/PC13CFG/PA04CFG/ PA05CFG/PA06CFG/PA07CFG/PA08CFG/ PA09CFG/PA10CFG/PD00CFG/PD01CFG/ PD12CFG/PD13CFG/PD14CFG/PD15CFG	4'h00	GPIO/default dual-purpose output
		4'h01	TO10
		4'h02	TO11
		4'h03	TO12
		4'h04	TO13
		4'h05	TxD1/IrTxD/SDO10
		4'h06	SPIHS0_SCKO
		4'h07	SPIHS0_MO
		4'h08	SPIHS0_SO
Others	Prohibited to set		
GRP2	PB01CFG/PB02CFG/PB03CFG/PB04CFG/ PB05CFG/PB06CFG/PB07CFG/PB08CFG/ PC00CFG/PC01CFG/PC02CFG/PA11CFG/ PA12CFG/PA13CFG/PA14CFG/PD02CFG/ PD03CFG/PD04CFG/PD05CFG/PD06CFG	4'h00	GPIO/default dual-purpose output
		4'h01	TO14
		4'h02	TO15
		4'h03	TO16
		4'h04	TO17
		4'h05	TxD2/SDO20
		4'h06	CLKBUZ1
Others	Prohibited to set		

Table 4.1.3 Digital function configuration list (2/2 input function configuration)

Grouping	Control register	Register configuration	Pin dual-purpose function
GRP0	TI00PCFG TI01PCFG TI02PCFG TI33PCFG RXD0PCFG(UART) SCLA0PCFG(IICA0) SDAA0PCFG(IICA1)	6'h00	Default dual-purpose input
		6'h01	PB00 as a dual input
		6'h02	PH04 as a dual input
		6'h03	PH03 as a dual input
		6'h04	PH02 as a dual input
		6'h05	PH01 as a dual input
		6'h06	PC14 as a dual input
		6'h07	PC15 as a dual input
		6'h08	PC08 as a dual input
		6'h09	PC09 as a dual input
		6'h0a	PC10 as a dual input
		6'h0b	PC11 as a dual input
		6'h0c	PA00 as a dual input
		6'h0d	PA01 as a dual input
		6'h0e	PA02 as a dual input
		6'h0f	PA03 as a dual input
		6'h10	PD07 as a dual input
		6'h11	PD08 as a dual input
		6'h12	PD09 as a dual input
6'h13	PD10 as a dual input		
6'h14	PD11 as a dual input		
	Others	Prohibited to set	
GRP1	TI10PCFG TI11PCFG TI12PCFG TI13PCFG RXD1PCFG(UART) SPIHS0_SCKPCFG(SPI) SPIHS0_SIPCFG(SPI) SPIHS0_MIPCFG(SPI)	6'h00	Default dual-purpose input
		6'h01	PC03 as a dual input
		6'h02	PC04 as a dual input
		6'h03	PC05 as a dual input
		6'h04	PC06 as a dual input
		6'h05	PC07 as a dual input
		6'h06	PC12 as a dual input
		6'h07	PC13 as a dual input
		6'h08	PA04 as a dual input
		6'h09	PA05 as a dual input
		6'h0a	PA06 as a dual input
		6'h0b	PA07 as a dual input
		6'h0c	PA08 as a dual input
		6'h0d	PA09 as a dual input
6'h0e	PA10 as a dual input		

		6'h0f	PD00 as a dual input
		6'h10	PD01 as a dual input
		6'h11	PD12 as a dual input
		6'h12	PD13 as a dual input
		6'h13	PD14 as a dual input
		6'h14	PD15 as a dual input
		Others	Prohibited to set
GRP2	TI14PCFG TI15PCFG TI16PCFG TI17PCFG RXD2PCFG(UART) SPIHS1_NSSPCFG(SPI) SCLA1PCFG(IICA1) SDA1PCFG(IICA1)	6'h00	Default dual-purpose input
		6'h01	PB01 as a dual input
		6'h02	PB02 as a dual input
		6'h03	PB03 as a dual input
		6'h04	PB04 as a dual input
		6'h05	PB05 as a dual input
		6'h06	PB06 as a dual input
		6'h07	PB07 as a dual input
		6'h08	PB08 as a dual input
		6'h09	PC00 as a dual input
		6'h0a	PC01 as a dual input
		6'h0b	PC02 as a dual input
		6'h0c	PA11 as a dual input
		6'h0d	PA12 as a dual input
		6'h0e	PA13 as a dual input
		6'h0f	PA14 as a dual input
		6'h10	PD02 as a dual input
		6'h11	PD03 as a dual input
		6'h12	PD04 as a dual input
		6'h13	PD05 as a dual input
6'h14	PD06 as a dual input		
Others	Prohibited to set		

Table 4.1.3 List of External Interrupt Pin Function Configuration

Pin	Control register	Register configuration	External interrupt port selection
INTP0	INTP0PCFG	3'h00	PC00
		3'h01	PC01
		3'h02	PC02
		3'h03	PC03
		3'h04	PC04
		3'h05	PC05
		3'h06	PC06
		3'h07	PC07
INTP1	INTP1PCFG	3'h00	PC12
		3'h01	PC13
		3'h02	PC14
		3'h03	PC15
		3'h04	PC08
		3'h05	PC09
		3'h06	PC10
		3'h07	PC11
INTP2	INTP2PCFG	3'h00	PA00
		3'h01	PA01
		3'h02	PA02
		3'h03	PA03
		3'h04	PA11
		3'h05	PA12
		3'h06	PA13
		3'h07	PA14
INTP3	INTP3PCFG	3'h00	PA04
		3'h01	PA05
		3'h02	PA06
		3'h03	PA07
		3'h04	PA08
		3'h05	PA09
		3'h06	PA10
		Others	Prohibited to set
INTP4	INTP4PCFG	3'h00	PD00
		3'h01	PD01
		3'h02	PD12
		3'h03	PD13
		3'h04	PD14
		3'h05	PD15
		3'h06	PD02
		3'h07	PD03
INTP5	INTP5PCFG	3'h00	PD04

		3'h01	PD05
		3'h02	PD06
		3'h03	PD07
		3'h04	PD08
		3'h05	PD09
		3'h06	PD10
		3'h07	PD11
INTP6	INTP6PCFG	3'h00	PB00
		3'h01	PH04
		3'h02	PH03
		3'h03	PH02
		3'h04	PH01
		3'h05	PB01
		3'h06	PB02
		Others	Prohibited to set
INTP7	INTP7PCFG	3'h00	PB03
		3'h01	PB04
		3'h02	PB05
		3'h03	PB06
		3'h04	PB07
		3'h05	PB08
		Others	Prohibited to set

4.2 Port multiplexing function

(1/2)

Function name	input/output	Function
ANI0~ANI34	input	Analog input of A/D converter
INTP0~INTP7	input	External interrupt request input. Designation of valid edges: rising edge, falling edge, rising and falling double edges
VCIN0	input	Analog voltage input of comparator 0
VCIN10, VCIN11, VCIN12, VCIN13	input	Comparator1's analog voltage/reference voltage input
VREF0	input	Reference voltage input of comparator0
VCOUT0, VCOUT1	output	Comparator output
PGA0IN	input	PGA input
PGA0_ADJOUT	output	PGA output
PGA0GND	input	PGA reference input
KR0~KR7	input	Key interrupt input
CLKBUZ0, CLKBUZ1	output	Clock output / buzzer output
RTC1HZ	output	Real-time clock correction clock (1Hz) output
RESETB	input	Low-level active system reset input. When external reset is not used, it must be connected to VDD directly or through a resistor.
RxD0~RxD2	input	Serial data input of serial interface UART0, UART1, UART2
TxD0~TxD2	output	Serial data output of serial interface UART0, UART1, UART2
SCL00, SCL01, SCL10, SCL11, SCL20, SCL21	output	Serial clock output of serial interface IIC00, IIC01, IIC10, IIC11, IIC20, IIC21
SDA00, SDA01, SDA10, SDA11, SDA20, SDA21	input/output	Serial data input/output of serial interface IIC00, IIC01, IIC10, IIC11, IIC20, IIC21
SCLK00, SCLK01, SCLK10, SCLK11, SCLK20, SCLK21	input/output	Serial clock input/output of serial interface SSPI00, SSPI01, SSPI10, SSPI11, SSPI20, SSPI21
SDI00, SDI01, SDI10, SDI11, SDI20, SDI21	input	Serial data input of serial interface SSPI00, SSPI01, SSPI10, SSPI11, SSPI20, SSPI21
SS00	input	Chip selection input of serial interface SSPI00
SDO00, SDO01, SDO10, SDO11, SDO20, SDO21	output	Serial data output of SSPI00, SSPI01, SSPI10, SSPI11, SSPI20, SSPI21
DBD0~DBD7	input/ output	LCD bus data input/output
DBRDB	output	LCD bus read enable output
DBWRB	output	LCD bus write enable output
QIO0~QIO3	input/ output	QSPI data input/output
QSPCLK	output	QSPI clock output
QSSL	output	QSPI slave select
SPIHS0_NSS	input	Chip select input of serial interface SPIHS0
SPIHS0_SCK	input/output	Serial clock input/output of serial interface SPIHS0
SPIHS0_MISO	input/output	Serial data input/output of serial interface SPIHS0

(2/2)

Function name	input/ output	Function
SPIHS0_MOSI	input/output	Serial data input/output of serial interface SPIHS0
SPIHS1_NSS	input	Chip select input of serial interface SPIHS1
SPIHS1_SCK	input/output	Serial clock input/output of serial interface SPIHS1
SPIHS1_MISO	input/output	Serial data input/output of serial interface SPIHS1
SPIHS1_MOSI	input/output	Serial data input/output of serial interface SPIHS1
SCLA0	input/output	Clock input/output of serial interface IICA0
SDAA0	input/output	Serial data input/output of serial interface IICA0
SCLA1	input/output	Clock input/output of serial interface IICA1
SDAA1	input/output	Serial data input/output of serial interface IICA1
TI00~TI03	input	16-bit timer Timer4 external count clock/capture trigger input
TO00~TO03	output	Timer output of 16-bit timer Timer4
TI10~TI17	input	16-bit timer Timer8 external count clock/capture trigger input
TO10~TO17	output	Timer output of 16-bit timer Timer8
USB_VBUSEN	output	VBUS enable signal from USB output to external power IC
USB_ID	input	ID input signal connected to MicroAB connector in OTG mode
USB_EXICEN	output	Output low power control signal to OTG power IC
USB_OVRCUA、USB_OVRCUB	input	Overcurrent port
USB_DP	input/output	D+ line De of USB transceiver
USB_DM	input/output	D-line of USB transceiver
USB_VBUS	input	USB connection detection port
UVDD	input/output	input: the power supply of the USB transceiver, output: the output port of the USB LDO.
SSIRXD0	input	Send data of serial audio interface SSI
SSITXD0	output	Receive data of serial audio interface SSI
SSILRCK0/SSIFS	input/output	Frame clock/frame synchronization of serial audio interface SSI
SSIBCK0	input/output	Serial audio interface SSI bit clock
SSIMCLK	input	The main clock of the serial audio interface SSI
X1、X2	—	Connect the resonator for the main system clock.
EXCLK	input	External clock input of main system clock
XT1、XT2	—	Connect the resonator for the subsystem clock.
EXCLKS	input	External clock input for subsystem clock
VDD	—	Power supply
AVREFP	input	Positive (+) reference voltage input of A/D converter
AVREFM	input	Negative (–) reference voltage input of A/D converter
VSS	—	Ground
SWDIO	input/output	SWD data interface
SWCLK	input	SWD clock interface

Remark: As a countermeasure for noise and locking, the bypass capacitor (about 0.1uF) must be connected with the shortest distance between VDD and VSS and thicker wiring.

5 Function summary

5.1 ARM® Cortex®-M0+ core

ARM's Cortex-M0(+) processor is a new generation of ARM processors for embedded systems. It provides a low-cost platform designed to meet the needs of a small pin count and low-power microcontroller, while providing excellent computing performance and advanced system response to interrupts.

The 32-bit RISC processor of the Cortex-M0(+) processor provides excellent code efficiency and the expected high performance of the ARM core, which is different from 8-bit and 16-bit devices of the same memory size. The Cortex-M0(+) processor has 32 address lines and a storage space of up to 4G.

BAT32G157 uses an embedded ARM core, so it is compatible with all ARM tools and software.

5.2 Memory

5.2.1 Flash

BAT32G157 has a built-in flash memory that can be programmed, erased and rewritten. Has the following functions:

- Programs and data share 256K storage space.
- 2.5KB dedicated data Flash memory
- Support page erasing, each page size is 512byte, erasing time 4ms
- Support byte/half-word/word (32bit) programming, programming time 24us

5.2.2 SRAM

BAT32G157 has built-in 32K bytes of embedded SRAM.

5.3 Enhanced DMA controller

Built-in enhanced DMA (Direct Memory Access) controller can realize the function of data transfer between memories without using CPU.

- It supports the start of DMA through peripheral function interrupts, and can realize real-time control through communication, timer and A/D.
- The transmission source/destination area is optional for the entire address space range (when the flash area is used as the destination address, the flash needs to be preset to the programming mode).
- Supports 4 transfer modes (normal transfer mode, repetitive transfer mode, block transfer mode and chain transfer mode).

5.4 Linkage controller

The linkage controller links each peripheral function output event with the peripheral function trigger source. So as to realize the coordinated operation between peripheral functions without using the CPU.

The linkage controller has the following functions:

- The event signals can be linked together to realize the linkage of peripheral functions.
- 15 types of event input, 4 types of event trigger.

5.5 Clock generation and start

The clock generation circuit is a circuit that generates a clock for the CPU and peripheral hardware. There are the following 4 types of system clocks and clock oscillation circuits.

5.5.1 Main system clock

- X1 oscillator circuit: It can generate 1-20MHz clock oscillation by connecting a resonator to the pins (X1 and X2), and can stop the oscillation by executing a deep sleep command or setting MSTOP.
- High-speed internal oscillator (high-speed OCO): The frequency can be selected for oscillation by the option byte. After the reset is released, the CPU defaults to start running with this high-speed internal oscillator clock. Oscillation can be stopped by executing a deep sleep instruction or setting the HIOSTOP bit. The frequency set by the option byte can be changed through the frequency selection register of the high-speed internal oscillator. The highest frequency is 64Mhz, and the accuracy is $\pm 1.0\%$.
- Input the external clock from the pin (X2): (1~20MHz), and the input of the external main system clock can be disabled by executing the deep sleep instruction or setting the MSTOP bit.

5.5.2 Subsystem clock

- XT1 oscillator circuit: It can generate 32.768kHz clock oscillation by connecting a 32.768kHz resonator to the pins (XT1 and XT2), and the oscillation can be stopped by setting the XTSTOP bit.
- Input the external clock from the pin (XT2): 32.768kHz, and the input of the external clock can be disabled by setting the XTSTOP bit.

5.5.3 Low-speed internal oscillator clock

- Low-speed internal oscillator (low-speed OCO): generates 15kHz (TYP.) clock oscillation. The low-speed internal oscillator clock can be used as the CPU clock. The following peripheral hardware can be run by the low-speed internal oscillator clock:
 - Watchdog timer (WWDT)
 - Real Time Clock (RTC)
 - 15-bit interval timer

5.5.4 PLL

- Built-in two PLLs: one is for system clock and the other is for USB. The source clock of the PLL can be either an external clock or a high-speed internal oscillator clock.

5.6 Power management

5.6.1 Power supply mode

VDD: external power supply, voltage range 1.8 to 5.5V

5.6.2 Power-on reset

The power-on reset circuit (POR) has the following functions:

- An internal reset signal is generated when the power is turned on. If the power supply voltage (VDD) is greater than the detection voltage (VPOR), the reset is released. However, before reaching the operating voltage range, the reset state must be maintained through a voltage detection circuit or an external reset.
- The power supply voltage (VDD) and the detection voltage (VPDR) are compared. When $VDD < VPDR$, an internal reset signal is generated. However, when the power supply drops, it must be shifted to the deep sleep mode before it falls below the operating voltage range, or set to the reset state through a voltage detection circuit or an external reset. If you want to restart operation, you must confirm that the power supply voltage has returned to the operating voltage range.

5.6.3 Voltage detection

The voltage detection circuit sets the operation mode and detection voltage (VLVDH, VLVDL, VLVD) through the option byte. The voltage detection (LVD) circuit has the following functions:

- Compare the power supply voltage (VDD) with the detection voltage (VLVDH, VLVDL, VLVD) and generate an internal reset or interrupt request signal.
- The detection voltage of the power supply voltage (VLVDH, VLVDL, VLVD) can select the detection level by the option byte.
- Can run in deep sleep mode.
- When the power supply rises, before reaching the operating voltage range, the reset state must be maintained through a voltage detection circuit or an external reset. When the power supply drops, it must be transferred to the deep sleep mode before being lower than the operating voltage range, or set to the reset state through a voltage detection circuit or an external reset.
- The operating voltage range varies according to the setting of the user option byte.

5.7 Low power consumption mode

BAT32G157 supports two low-power modes to achieve the best compromise between low power consumption, short startup time, and available wake-up sources:

- Sleep mode: Enter the sleep mode by executing the sleep command. The sleep mode is a mode in which the CPU operating clock is stopped. Before setting the sleep mode, if the high-speed system clock oscillator circuit, high-speed internal oscillator, or subsystem clock oscillator circuit is oscillating, each clock continues to oscillate. Although this mode cannot reduce the operating current to the level of the

deep sleep mode, it is an effective mode when you want to restart processing immediately through an interrupt request or when you want to perform intermittent operation frequently.

- Deep sleep mode: Enter the deep sleep mode by executing the deep sleep command. The deep sleep mode is a mode to stop the oscillation of the high-speed system clock oscillation circuit and the high-speed internal oscillator and stop the entire system. Can greatly reduce the operating current of the chip. Because the deep sleep mode can be cancelled by an interrupt request, intermittent operation is also possible. However, in the case of the X1 clock, because it is necessary to ensure the wait time for stable oscillation when releasing the deep sleep mode, if you must start processing immediately with an interrupt request, you must select the sleep mode.

In either mode, the registers, flags, and data memory all retain the contents before the standby mode, and also maintain the status of the output latch and output buffer of the input/output port.

5.8 Reset function

The following 7 methods to generate a reset signal:

- 1) Input external reset through RESETB pin.
- 2) Generate an internal reset through the program runaway detection of the watchdog timer.
- 3) The internal reset is generated by comparing the power supply voltage of the power-on reset (POR) circuit and the detection voltage.
- 4) The internal reset is generated by comparing the power supply voltage of the voltage detection circuit (LVD) and the detection voltage.
- 5) Internal reset due to RAM parity error.
- 6) Internal reset due to access to illegal memory.
- 7) Software reset

The internal reset is the same as the external reset. After the reset signal is generated, the program is executed from the addresses written in addresses 0000H and 0001H.

5.9 Interrupt function

The Cortex-M0+ processor has a built-in nested vectored interrupt controller (NVIC), which supports up to 32 interrupt request (IRQ) inputs and 1 non-maskable interrupt (NMI) input. In addition, the processor also supports multiple internal exceptions.

This product has processed 32 maskable interrupt requests (IRQ) and 1 non-maskable interrupt (NMI). For details, please refer to the corresponding chapters of the user manual. The actual number of interrupt sources varies by product.

5.10 Real time clock (RTC)

The real-time clock (RTC) has the following functions.

- Counter with year, month, week, day, hour, minute and second.
- Fixed period interrupt function (period: 0.5 second, 1 second, 1 minute, 1 hour, 1 day, 1 month)
- Alarm interrupt function (alarm clock: week, hour, minute)
- 1Hz pin output function
- Support the division of the subsystem clock or the main system clock as the running clock of the RTC
- The real-time clock interrupt signal (INTRTC) can be used as a wake-up from deep sleep mode
- Support a wide range of clock correction functions

Only when the sub-system clock (32.768kHz) or the divided frequency of the main system clock is selected as the running clock of the RTC, the year, month, week, day, hour, minute and second can be counted. When the low-speed internal oscillator clock (15kHz) is selected, only the fixed cycle interrupt function can be used.

5.11 Watchdog timer

1 channel WWDT, 17bit watchdog timer is set to count operation by option byte. The watchdog timer runs on the low-speed internal oscillator clock (15kHz). The watchdog timer is used to detect program runaway. When a program out of control is detected, an internal reset signal is generated.

The following conditions are judged to be out of control of the program:

- When the watchdog timer counter overflows
- When a 1-bit operation instruction is executed on the enable register (WDTE) of the watchdog timer
- When writing data other than "ACH" to the WDTE register
- When writing data to the WDTE register while the window is closed

5.12 SysTick timer

This timer is dedicated to the real-time operating system, but it can also be used as a standard down counter.

Its characteristics are: when the 24-bit down counter self-filling capacity counter reaches 0, a maskable system interrupt is generated.

5.13 Timer timer4/timer8

This product has a built-in timer unit timer4 with 4-channel 16-bit timer and a timer unit timer8 with 8-channel 16-bit customized timer. Each 16-bit timer is called a "channel", which can be used as an independent timer or combined with multiple channels for advanced timer functions.

For details of each function, please refer to the table below:

Independent channel operation function	Multi-channel linkage operation function
<ul style="list-style-type: none"> ● Interval timer ● Square wave output ● External event counter ● Frequency divider ● Measurement of input pulse interval ● Measurement of the high/low level width of the input signal ● Delay counter 	<ul style="list-style-type: none"> ● One-shot pulse output ● PWM output ● Multiple PWM output

5.13.1 Independent channel operation function

The independent channel operation function is a function that can independently use any channel without being affected by the operation mode of other channels. The independent channel operation function can be used in the following modes:

- 1) Interval timer: Can be used as a reference timer that generates interrupts (INTTM) at regular intervals.
- 2) Square wave output: Whenever an INTTM interrupt is generated, a flip is triggered, and a square wave with a 50% duty cycle is output from the timer output pin (TO).
- 3) External event counter: Count the valid edge of the input signal of the timer input pin (TI), and if it reaches the specified number of times, it can be used as an event counter to generate an interrupt.
- 4) Frequency divider function (only limited to channel 0 of unit 0): divide the input clock of the timer input pin (TI00), and then output from the output pin (TO00).
- 5) Input pulse interval measurement: start counting at the valid edge of the input pulse signal of the timer input pin (TI) and capture the count value at the valid edge of the next pulse to measure the interval of the input pulse.
- 6) Measurement of the high/low level width of the input signal: start counting on one edge of the input signal of the timer input pin (TI) and capture the count value on the other edge to measure the high or low level of the input signal Width.
- 7) Delay counter: start counting at the valid edge of the input signal of the timer input pin (TI) and generate an interrupt after any delay period has elapsed.

5.13.2 Multi-channel linkage operation function

Multi-channel linkage operation function can be realized by combining the master channel (the basic timer of the main control cycle) and the slave channel (the timer that follows the master control channel). Multi-channel linkage operation function can be used in the following modes:

- 1) One-shot pulse output: Use two channels in pairs to generate one-shot pulses that can set the output timing and pulse width arbitrarily.
- 2) PWM (Pulse Width Modulation) output: Use 2 channels in pairs to generate pulses with a period and duty cycle that can be set arbitrarily.
- 3) Multiple PWM (Pulse Width Modulation) output: It can generate up to 7 kinds of PWM signals with any duty cycle in a fixed cycle by expanding the PWM function and using 1 master channel and multiple slave channels.

5.13.3 8-bit timer operation function

The 8-bit timer operation function can use the 16-bit timer channel as a function of two 8-bit timer channels. (Only channel 1 and channel 3 can be used)

5.13.4 LIN-bus support function

The timer4 unit can be used to check whether the received signal in LIN-bus communication is suitable for the LIN-bus communication format.

- 1) Wake-up signal detection: Start counting on the falling edge of the input signal of the UART serial data input pin (RxD) and capture the count value on the rising edge to measure the low-level width. If the low-level width is greater than or equal to a certain fixed value, it is considered as a wake-up signal.
- 2) Interval field detection: After detecting the wake-up signal, start counting from the falling edge of the input signal of the UART serial data input pin (RxD) and capture the count value on the rising edge to measure the low-level width. If the width of the low level is greater than or equal to a certain fixed value, it is regarded as an interval field.
- 3) Synchronous field pulse width measurement: After detecting the interval field, measure the low-level width and high-level width of the input signal of the UART serial data input pin (RxD). Calculate the baud rate based on the bit interval of the sync field measured in this way.

5.14 EPWM output control circuit

Use Timer4's PWM output function to control one DC motor or two stepping motors. By truncating the source CMP0 output, INTPO input and EVENTC events, the output can be truncated. Through the setting of the software, you can choose from four types of output that are Hi-Z output, low-level output, high-level output, and forbidden cut-off output.

5.15 15-bit interval timer

This product has a built-in 15-bit interval timer, which can generate interrupts (INTIT) at any time interval set in advance, and can be used to wake up from deep sleep mode.

5.16 Clock output/buzzer output control circuit

The clock output controller is used to provide the clock to the peripheral IC, and the buzzer output controller is used to output the square wave of the buzzer frequency. Clock output or buzzer output is realized by dedicated pins.

5.17 Universal serial communication unit (SCI)

This product has two built-in universal serial communication units, and each unit has up to 4 serial communication channels. It can realize the communication functions of standard SPI, simple SPI, UART and simple I2C. Take the 64pin product as an example, the function allocation of each channel is as follows:

5.17.1 3-wire serial interface (simple SPI)

Synchronize data transmission and reception with the serial clock (SCK) output from the master control device.

This is a clock synchronous communication interface that uses 1 serial clock (SCK), 1 sending serial data (SO), and 1 receiving serial data (SI) to communicate with a total of 3 communication lines.

[data transmission and reception]

- 7-bit or 8-bit data length
- Phase control of sending and receiving data
- MSB/LSB priority choice

[clock control]

- Choice of master control or slave
- Phase control of input/output clock
- The transmission cycle generated by the prescaler and the internal counter of the channel
- Maximum transfer rate

Master communication: $\text{Max.fCLK}/2$

Slave communication: $\text{Max.fMCK}/6$

[Interrupt function]

- Transmission end interrupt, buffer empty interrupt

[Error detection flag]

- Overflow error

5.17.2 Simple SPI with slave chip select function

SPI serial communication interface supporting slave chip select input function. This is a clock synchronization that uses a slave chip select input (SS1), a serial clock (SCK), a sending serial data (SO), and a receiving serial data (SI) 4 communication lines for communication. Communication Interface.

[Data sending and receiving]

- 7-bit or 8-bit data length
- Phase control of sending and receiving data
- MSB/LSB priority choice
- Level setting of sending and receiving data

[clock control]

- Phase control of input/output clock
- The transmission cycle generated by the prescaler and the internal counter of the channel
- Maximum transfer rate

Slave communication: Max.fMCK/6

[Interrupt function]

- Transmission end interrupt, buffer empty interrupt

[Error detection flag]

- Overflow error

5.17.3 UART

The function of asynchronous communication through two lines of serial data transmission (TxD) and serial data reception (RxD). Use these two communication lines to send and receive data asynchronously (using the internal baud rate) with other communication parties according to the data frame (consisting of start bit, data, parity bit and stop bit). Full-duplex UART communication can be realized by using two channels dedicated for transmission (even-numbered channels) and dedicated for reception (odd-numbered channels), and LIN-bus can be supported by combining timer4 units and external interrupts (INTP0).

[Data sending and receiving]

- 7-bit, 8-bit or 9-bit data length
- MSB/LSB priority choice
- Selection of level setting and reverse phase of sending and receiving data
- Additional parity check bit, parity check function
- Additional stop bit, stop bit detection

[Interrupt function]

- Transmission end interrupt, buffer empty interrupt
- Error interrupt caused by framing error, parity error or overflow error

[Error detection flag]

- Frame error, parity error, overflow error

[LIN-bus function]

- Wake-up signal detection
- BF detection
- Measurement of synchronization field, calculation of baud rate

5.17.4 Simple I2C

The function of clock synchronization communication with multiple devices through two lines of serial clock (SCL) and serial data (SDA). Because this simple I2C is designed for single communication with flash memory, A/D converters and other devices, it can only be used as a master device. The start condition and stop condition are the same as the operation control register, and must comply with the AC characteristics and be processed by software.

[Data sending and receiving]

- Main control sending, main control receiving (only limited to the main control function of single main control)
- ACK output function, ACK detection function
- 8-bit data length (when sending the address, use the upper 7 bits to specify the address, and use the lowest bit for R/W control)
- Generate start and stop conditions through software

[interrupt function]

- End of transmission interrupt

[Error detection flag]

- ACK error, overflow error

[Functions not supported by simple I2C]

- Slave sending, slave receiving
- Multi-master control function (arbitration failure detection function)
- Waiting for detection function

5.18 Standard serial peripheral interface (SPI)

The serial interface SPI has the following 2 modes:

- Operation stop mode: This is a mode used when serial transmission is not performed, which can reduce power consumption
- 3-wire serial I/O mode: This mode uses 3 lines of serial clock (SCK) and serial data bus (MISO and MOSI) to transmit 8-bit or 16-bit data with multiple devices.

5.19 Standard serial interface (IICA)

The serial interface IICA has the following 3 modes:

- Operation stop mode: This is a mode used when serial transmission is not performed, which can reduce power consumption.
- I2C bus mode (supports multiple masters): This mode uses 2 lines of serial clock (SCLA) and serial data bus (SDAA) to transmit 8-bit data with multiple devices. In line with the I2C bus format, the master device can generate "start condition", "address", "indication of the transfer direction", "data" and "stop condition" for the slave device on the serial data bus. The slave device automatically detects the received status and data through hardware. This function can simplify the I2C bus control part of the application. Because the SCLA pin and SDAA pin of the serial interface IICA are used as open-drain output, the serial clock line and the serial data bus require a pull-up resistor.
- Wake-up mode: In the deep sleep mode, when the extension code or the local station address from the autonomous control device is received, the deep sleep mode can be released by generating an interrupt request signal (INTIICA). Set through the IICA control register.

5.20 LCD BUS interface

The LCD bus interface has the following functions:

- Support two different bus standards: 8080 mode, 6800 mode
- Support 8-bit/16-bit read and write operations
- Controllable transmission speed (up to 10MHz)
- When internal data transmission is enabled or external bus access is completed, DMA transmission can be triggered
- Support DMA read and write

5.21 Enhanced serial audio interface (SSIE)

1-channel serial audio interface, which can send and receive audio devices to multiple devices that support different audio data formats:

- Communication mode: master or slave, send and receive (full duplex communication)
- Communication format: I2S format, mono format
- FIFO: 4 bytes * 8 segments transmit or receive FIFO

5.22 Quad Serial Peripheral Interface (QSPI)

1-channel Quad Serial Peripheral Interface module (QSPI) is a memory controller for connecting a serial ROM (nonvolatile-memory such as a serial flash memory, serial EEPROM, or serial FeRAM) that has an SPI-compatible interface.

- Support extended SPI, Dual SPI, Quad SPI protocols
- Configurable to SPI mode 0 and SPI mode 3
- Address width selectable from 8, 16, 24, or 32 bits
- Timing adjustment function to support a wide range of serial flash configurations
- Flash read function for the read, fast read, fast read dual output, fast read dual I/O, fast read quad output, and fast read quad I/O instructions
- Serial flash instructions and functions through software control, including erase, write, ID read, and power-down control

5.23 Universal Serial Bus (USB)

1-channel USB module, compatible with USB 2.0 specification, supports host controller mode, device controller mode and OTG function. The host controller supports full-speed and low-speed transmission, and the device controller supports full-speed transmission. The built-in USB transceiver supports control transmission, synchronous transmission, batch transmission and interrupt transmission.

It supports a data transmission FIFO with a maximum of 10 pipes, and pipe 0 is the default DCP pipe. According to peripheral equipment and communication requirements, any endpoint number can be configured to pipes 1~9.

Compatible with USB BC1.2 specification.

5.24 Analog-to-digital converter (ADC)

This product has a built-in 12-bit resolution analog-to-digital converter SARADC, which can convert analog input to digital value and supports up to 35 channels of ADC analog input (ANI0~ANI34). The ADC contains the following functions:

- 12-bit resolution, conversion rate 1.42MSPS.
- Trigger mode: support software trigger, hardware trigger and hardware trigger in standby state
- Channel selection: support two modes of single-channel selection and multi-channel scanning
- Conversion mode: support single conversion and continuous conversion
- Working voltage: Support the working voltage range of $1.8V \leq VDD \leq 5.5V$
- It can detect the built-in reference voltage (1.45V) and temperature sensor.

ADC can set various A/D conversion modes through the following mode combinations.

Trigger mode	Software trigger	Start the conversion by software operation.
	Hardware trigger no wait mode	Start the conversion by detecting the hardware trigger.
	Hardware trigger wait mode	In the conversion standby state with the power off, the power is turned on by detecting the hardware trigger, and the conversion starts automatically after the A/D power stabilization wait time.
Channel selection mode	Select mode	Select 1 channel of analog input for A/D conversion.
	Scan mode	Perform A/D conversion on 4 channels of analog input in sequence. It is possible to select 4 consecutive channels from ANI0 to ANI15 as analog input.
Conversion mode	Single conversion mode	Perform 1 A/D conversion on the selected channel.
	Continuous conversion mode	Perform continuous A/D conversion on the selected channel until it is stopped by software.
Sampling time/conversion time	Number of sampling clocks/number of conversion clocks	The sampling time can be set by the register. The default value of the sampling clock is 13.5 clk, and the Min value of the conversion clock is 31.5 clk.

5.25 Programmable gain amplifier (PGA)

This product has a built-in programmable gain amplifier (PGA0), which has the following functions:

- Multi-stage gain optional (1/2/4/8/16/32/64/128)
- PGA0 output with sample and hold circuit
- Support offset voltage trimming
- Support single-ended/pseudo-differential input
- Support PGA output test.
- PGA output can be connected to internal analog comparator input for shaping.
- The output of PGA0 can be selected as analog input for A/D converter or analog input for positive terminal of comparator0 (CMP0).
- Support offset voltage software trimming.

5.26 Comparator (CMP)

This product has built-in two channels with hysteresis comparator CMP0 and CMP1, with the following functions:

- Can choose comparator high-speed mode, comparator low-speed mode or comparator window mode.
- Can select external reference voltage input and internal reference voltage for reference voltage.
- The elimination width of the noise elimination digital filter can be selected.
- Can detect the valid edge of the comparator output and generate an interrupt signal.
- It can detect the valid edge of the comparator output and output the event signal to the linkage controller.

5.27 Two-wire serial debug port (SW-DP)

ARM's SW-DP interface allows to connect to the microcontroller through a serial wire debugging tool.

5.28 Security function

5.28.1 Flash CRC calculation function (high-speed CRC, general-purpose CRC)

Detect the data error of flash memory through CRC operation.

According to different purposes and conditions of use, the following 2 CRCs can be used respectively.

- High-speed CRC: In the initialization program, it can stop the operation of the CPU and check the entire code flash area at high speed.
- General CRC: In CPU operation, it is not limited to the code flash area but can be used for multi-purpose checking.

5.28.2 RAM Parity error detection function

When reading RAM data, detect parity errors.

5.28.3 SFR protection function

Prevent the important SFR (Special Function Register) from being rewritten due to CPU runaway.

5.28.4 Illegal memory access detection function

Detect illegal access to illegal memory area (area without memory or area with restricted access).

5.28.5 Frequency detection function

Can use timer4 unit to self-check CPU or peripheral hardware clock frequency.

5.28.6 A/D test function

Perform A/D conversion on the A/D converter's positive (+) reference voltage, negative (–) reference voltage, analog input channel (ANI), temperature sensor output voltage, and internal reference voltage Self-test.

5.28.7 Digital output signal level detection function of input/output port

When the input/output port is in output mode, the output level of the pin can be read.

5.29 Key function

The input pin (KR0~KR7) can be interrupted by the key to generate a key interrupt (INTKR).

6 Electrical characteristics

6.1 Typical application peripheral circuit

The device connection reference of the typical MCU application peripheral circuit is as follows:

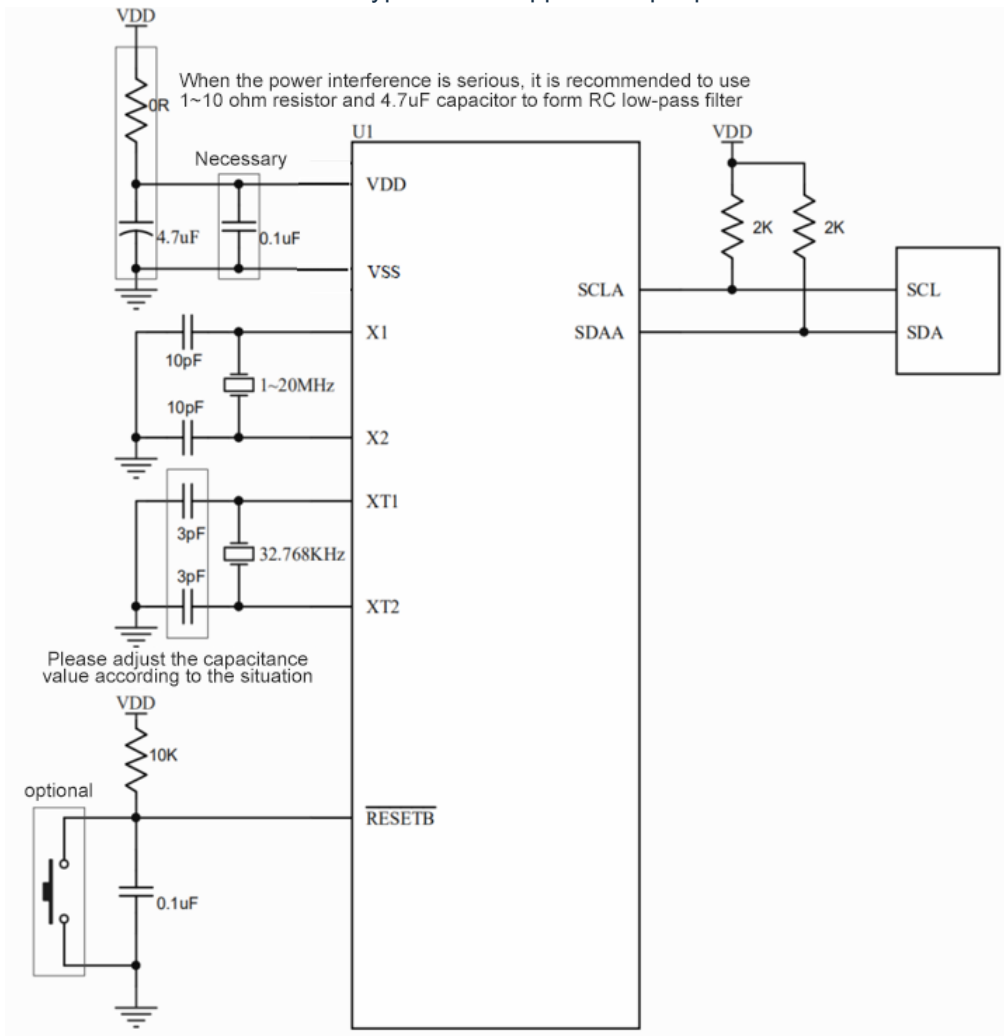

6.2 Absolute maximum voltage rating

($T_A = -40 \sim +105^\circ\text{C}$)

Item	Symbol	Condition	Rating	Unit
Source voltage	VDD		- 0.5~+6.5	V
Input voltage	VI	PA00~PA14、PB00~PB06、PC00~PC15、 PD00~PD15、PH00~PH04、EXCLK、EXCLKS、 RESETB	- 0.3~VDD+0.3 ^{note1}	V
Output voltage	VO	PA00~PA14、PB00~PB06、PC00~PC15、 PD00~PD15、PH01~PH04	- 0.3~VDD+0.3 ^{note1}	V
Analog input voltage	VAI	ANI0~ANI24、ANI27~ANI36	- 0.3~VDD+0.3 and - 0.3~AVREF(+)+0.3 ^{note1, 2}	V

Note: 1. Do not exceed 6.5V.

2. The pin of the A/D conversion target cannot exceed AVREF(+)+0.3.

Note: Even if one of the items exceeds the absolute maximum rating for an instant, the quality of the product may be degraded. The absolute maximum rating is a rating that may cause physical damage to the product, and the product must be used under the condition that the rating is not exceeded.

Remarks:

1. Unless otherwise specified, the characteristics of multiplexed pins are the same as those of port pins.
2. AVREF(+): The positive (+) reference voltage of the A/D converter
3. Use VSS as the reference voltage.

6.3 Absolute maximum current rating

(TA=-40~+105°C)

Item	Symbol	Condition		Rating	Unit
High level output current	IOH1	Each pin	PA00~PA14、PB00~PB06、PC00~PC15、PD00~PD15、PH01~PH04	- 40	mA
		Total pins-170mA	PB00~PB06、PD00~PD15	- 70	mA
			PA00~PA14、PC00~PC15	- 100	mA
	IOH2	Each pin	PH01~PH04	- 3	mA
		Total pins		- 15	mA
	Low-level output current	IOL1	Each pin	PA00~PA14、PB00~PB06、PC00~PC15、PD00~PD15、PH01~PH04	40
Total pins 170mA			PB00~PB06、PD00~PD15	100	mA
			PA00~PA14、PC00~PC15	120	mA
IOL2		Each pin	PH01~PH04	15	mA
		Total pins		45	mA
Working temperature		TA	Normally run		- 40~+105
	When flash programming				
Storage temperature	Tstg			- 65~+150	°C

Note: Even if one of the items exceeds the absolute maximum rating for an instant, the quality of the product may be degraded. The absolute maximum rating is a rating that may cause physical damage to the product, and the product must be used under the condition that the rating is not exceeded.

Remark: Unless otherwise specified, the characteristics of multiplexed pins are the same as those of port pins.

6.4 Oscillation circuit characteristics

6.4.1 X1, XT1 characteristics

($T_A = -40 \sim +105^\circ\text{C}$, $1.8\text{V} \leq \text{VDD} \leq 5.5\text{V}$, $\text{VSS} = 0\text{V}$)

item	Resonator	condition	MIN	TYP	MAX	unit
X1 clock oscillation frequency (fx)	Ceramic resonator/crystal resonator	$1.8\text{V} \leq \text{VDD} \leq 5.5\text{V}$	1.0	-	20.0	MHz
XT1 clock oscillation frequency (fxt)	Crystal resonator	$1.8\text{V} \leq \text{VDD} \leq 5.5\text{V}$	32	32.768	35	kHz

Note:

- It only indicates the allowable frequency range of the oscillation circuit. Please refer to the AC characteristics for the command execution time.
- Please entrust the resonator manufacturer to evaluate after installing the circuit, and use it after confirming the oscillation characteristics.

6.4.2 Internal oscillator characteristics

($T_A = -40 \sim +105^\circ\text{C}$, $1.8\text{V} \leq \text{VDD} \leq 5.5\text{V}$, $\text{VSS} = 0\text{V}$)

resonator	condition	MIN	TYP	MAX	unit
High-speed internal oscillator clock frequency (fIH) ^{note1,2}		1.0		64.0	MHz
Clock frequency accuracy of high-speed internal oscillator	$T_A = -20 \sim +105^\circ\text{C}$	-1.0		+1.0	%
	$T_A = -40 \sim -20^\circ\text{C}$	-1.5 ^{note3}		+1.5 ^{note3}	%
Clock frequency of low-speed internal oscillator (fIL)		10	15	20	kHz

Note:

- Select the frequency of the high-speed internal oscillator by the option byte.
- It only shows the characteristics of the oscillation circuit, please refer to the AC characteristics for the command execution time.
- Low temperature specification value is guaranteed by design, mass production does not measure low temperature condition.

6.4.3 PLL oscillator characteristics

($T_A = -40 \sim +105^\circ\text{C}$, $1.8\text{V} \leq \text{VDD} \leq 5.5\text{V}$, $\text{VSS} = 0\text{V}$)

resonator	condition	MIN	TYP	MAX	unit
PLL input frequency note ¹		4.0		8.0	MHz
PLL lock time		40			μs
UPLL input frequency		4.0		8.0	MHz
UPLL lock time		40			μs

Note: 1. It only shows the characteristics of the oscillation circuit, please refer to the AC characteristics for the command execution time

6.5 DC characteristics

6.5.1 Pin characteristics

($T_A = -40 \sim +105^\circ\text{C}$, $1.8\text{V} \leq \text{VDD} \leq 5.5\text{V}$, $\text{VSS} = 0\text{V}$)

item	symbol	condition	MIN	TYP	MAX	unit	
high level output Current ^{note1}	IOH1	PA00~PA14、PB00~PB06、PC00~PC15、PD00~PD15 1 pin alone	$1.8\text{V} \leq \text{VDD} \leq 5.5\text{V}$ $-40 \sim +85^\circ\text{C}$			-12.0 ^{note2}	mA
			$1.8\text{V} \leq \text{VDD} \leq 5.5\text{V}$ $85 \sim +105^\circ\text{C}$			-6.0 ^{note2}	
	IOH1	PB00~PB06、PD00~PD15 Total pins (when duty cycle $\leq 70\%$ ^{note3})	$4.0\text{V} \leq \text{VDD} \leq 5.5\text{V}$ $-40 \sim +85^\circ\text{C}$			-60.0	mA
			$4.0\text{V} \leq \text{VDD} \leq 5.5\text{V}$ $85 \sim +105^\circ\text{C}$			-30.0	
			$2.4\text{V} \leq \text{VDD} < 4.0\text{V}$			-12.0	mA
			$1.8\text{V} \leq \text{VDD} < 2.4\text{V}$			-6.0	mA
	IOH1	PA00~PA14、PC00~PC15 Total pins (when duty cycle $\leq 70\%$ ^{note3})	$4.0\text{V} \leq \text{VDD} \leq 5.5\text{V}$ $-40 \sim +85^\circ\text{C}$			-80.0	mA
			$4.0\text{V} \leq \text{VDD} \leq 5.5\text{V}$ $85 \sim +105^\circ\text{C}$			-30.0	
			$2.4\text{V} \leq \text{VDD} < 4.0\text{V}$			-20.0	mA
			$1.8\text{V} \leq \text{VDD} < 2.4\text{V}$			-10.0	mA
	IOH1	Total pins (when duty cycle $\leq 70\%$ ^{note3})	$1.8\text{V} \leq \text{VDD} \leq 5.5\text{V}$ $-40 \sim +85^\circ\text{C}$			-140.0	mA
			$1.8\text{V} \leq \text{VDD} \leq 5.5\text{V}$ $85 \sim +105^\circ\text{C}$			-60.0	
	IOH2	PH01~PH04 1 pin alone	$1.8\text{V} \leq \text{VDD} \leq 5.5\text{V}$			-2.5 ^{note2}	mA
Total pins (when duty cycle $\leq 70\%$ ^{note3})			$1.8\text{V} \leq \text{VDD} \leq 5.5\text{V}$			-10	mA

Note:

1. This is the current value that guarantees the operation of the device even if current flows from the VDD pin to the output pin.
2. Can not exceed the total current value.
3. This is the output current value of "duty cycle $\leq 70\%$ condition".

To change the output current value with a duty cycle $> 70\%$ can be calculated with the following calculation formula (when the duty cycle is changed to $n\%$).

• The total output current of the pins = $(\text{IOH} \times 0.7) / (n \times 0.01)$

<example> $\text{IOH} = -10.0\text{mA}$, $n = 80\%$

The total output current of the pins = $(-10.0 \times 0.7) / (80 \times 0.01) \approx -8.7\text{mA}$

The current of each pin does not change due to the duty cycle, and no current above the absolute maximum rating will flow.

Remark: Unless otherwise specified, the characteristics of multiplexed pins are the same as those of port pins.

(T_A=-40~+105°C、1.8V≤VDD≤5.5V、VSS=0V)

item	symbol	condition	MIN	TYP	MAX	unit
Low-level output current ^{note 1}	IOL1	PA00~PA14、PB00~PB06、PC00~PC15、PD00~PD15 1 pin alone	1.8V≤VDD≤5.5V -40~+85°C		35 ^{note 2}	mA
			1.8V≤VDD≤5.5V 85~+105°C		20 ^{note 2}	
		PB00~PB06、PD00~PD15 Total pins (when duty cycle ≤70% ^{note3})	4.0V≤VDD≤5.5V -40~+85°C		100	mA
			4.0V≤VDD≤5.5V 85~+105°C		70	
			2.4V≤VDD<4.0V		30	mA
			1.8V≤VDD<2.4V		15	mA
		PA00~PA14、PC00~PC15 Total pins (when duty cycle ≤70% ^{note3})	4.0V≤VDD≤5.5V -40~+85°C		120	mA
			4.0V≤VDD≤5.5V 85~+105°C		80	
			2.4V≤VDD<4.0V		40	mA
			1.8V≤VDD<2.4V		20	mA
	Total pins (when duty cycle ≤70% ^{note3})	1.8V≤VDD≤5.5V -40~+85°C		150	mA	
		1.8V≤VDD≤5.5V 85~+105°C		100		
	IOL2	PH01~PH04 1 pin alone Total pins (when duty cycle ≤70% ^{note3})	1.8V≤VDD≤5.5V		10 ^{note 2}	mA
			1.8V≤VDD≤5.5V		40	

Note:

1. This is the current value that guarantees the operation of the device even if the current flows from the output pin to the VSS pin.
2. Can not exceed the total current value.
3. This is the output current value of "duty cycle≤70% condition".

The output current value with a duty cycle> 70% can be calculated with the following calculation formula (when the duty cycle is changed to n%)

$$\bullet \text{ The total output current of the pins} = (IOL \times 0.7) / (n \times 0.01)$$

<example> IOL= 10.0mA、n = 80%

$$\text{The total output current of the pins} = (10.0 \times 0.7) / (80 \times 0.01) \approx 8.7\text{mA}$$

The current of each pin does not change due to the duty cycle, and no current above the absolute maximum rating will flow.

Remark: Unless otherwise specified, the characteristics of multiplexed pins are the same as those of port pins.

$(T_A = -40 \sim +105^\circ\text{C}, 1.8\text{V} \leq \text{VDD} \leq 5.5\text{V}, \text{VSS} = 0\text{V})$

item	symbol	condition		MIN	TYP	MAX	unit
High level input voltage	VIH1	PA00~PA14, PB00~PB06, PC00~PC15, PD00~PD15, PH00~PH04, EXCLK, EXCLKS, RESETB	Schmitt input	0.8VDD		VDD	V
Low-level input voltage	VIL1	PA00~PA14, PB00~PB06, PC00~PC15, PD00~PD15, PH00~PH04, EXCLK, EXCLKS, RESETB	Schmitt input	0		0.2VDD	V

Note: Unless otherwise specified, the characteristics of multiplexed pins are the same as those of port pins.

 $(T_A = -40 \sim +105^\circ\text{C}, 1.8\text{V} \leq \text{VDD} \leq 5.5\text{V}, \text{VSS} = 0\text{V})$

item	symbol	condition		MIN	TYP	MAX	unit
High level output voltage	VOH1	PA00~PA14, PB00~PB06, PC00~PC15, PD00~PD15	4.0V ≤ VDD ≤ 5.5V, IOH1 = - 12.0mA	VDD - 1.5			V
			4.0V ≤ VDD ≤ 5.5V, IOH1 = - 6.0mA	VDD - 0.7			V
			2.4V ≤ VDD ≤ 5.5V, IOH1 = - 3.0mA	VDD - 0.6			V
			1.8V ≤ VDD ≤ 5.5V, IOH1 = - 2mA	VDD - 0.5			V
	VOH2	PH01~04	4.0V ≤ VDD ≤ 5.5V, IOH2 = - 2.5mA	VDD - 1.5			V
			4.0V ≤ VDD ≤ 5.5V, IOH2 = - 1.5mA	VDD - 0.7			V
			2.4V ≤ VDD ≤ 5.5V, IOH2 = - 0.5mA	VDD - 0.6			V
			1.8V ≤ VDD ≤ 5.5V, IOH2 = - 0.4mA	VDD - 0.5			V
Low-level output voltage	VOL1	PA00~PA14, PB00~PB06, PC00~PC15, PD00~PD15	4.0V ≤ VDD ≤ 5.5V, IOL1 = 35.0mA			1.2	V
			4.0V ≤ VDD ≤ 5.5V, IOL1 = 20.0mA			0.7	V
			2.4V ≤ VDD ≤ 5.5V, IOL1 = 9.0mA			0.4	V
			1.8V ≤ VDD ≤ 5.5V, IOL1 = 6.0mA			0.4	V
	VOL2	PH01~04	4.0V ≤ VDD ≤ 5.5V, IOL2 = 10.0mA			1.2	V
			4.0V ≤ VDD ≤ 5.5V, IOL2 = 6.0mA			0.7	V
			2.4V ≤ VDD ≤ 5.5V, IOL2 = 2.5mA			0.4	V
			1.8V ≤ VDD ≤ 5.5V, IOL2 = 1.5mA			0.4	V

Note: Unless otherwise specified, the characteristics of multiplexed pins are the same as those of port pins

($T_A = -40 \sim +105^\circ\text{C}$, $1.8\text{V} \leq V_{DD} \leq 5.5\text{V}$, $V_{SS} = 0\text{V}$)

item	symbol	condition	MIN	TYP	MAX	unit	
High-level input leakage current	ILIH1	PA00~PA14, PB00~PB06, PC00~PC15, PD00~PD15, PH00	VI=VDD			1	μA
	ILIH2	RESETB	VI=VDD			1	μA
	ILIH3	PH01~04 (X1, X2, EXCLK, XT1, XT2, EXCLKS)	VI=VDD, when input port and external clock input			1	μA
VI=VDD, when the resonator is connected					10	μA	
Low-level input leakage current	ILIL1	PA00~PA14, PB00~PB06, PC00~PC15, PD00~PD15, PH00	VI=VSS			-1	μA
	ILIL2	RESETB	VI=VSS			-1	μA
	ILIL3	PH01~04 (X1, X2, EXCLK, XT1, XT2, EXCLKS)	VI=VSS, when input port and external clock input			-1	μA
VI=VSS, when the resonator is connected					-10	μA	
Internal pull-up resistor	RU	PA00~PA06, PA10~PA14, PB00~PB06, PC00~PC15, PD00~PD15, PH00~PH02	VI=VSS, when input port	10	30	100	$\text{K}\Omega$
Internal pull-down resistor	RD	PA00~PA06, PA09~PA14, PB00~PB06, PC00~PC15, PD00~PD15	VI=VDD, when input port	10	30	100	$\text{K}\Omega$

Note: Unless otherwise specified, the characteristics of multiplexed pins are the same as those of port pins.

6.5.2 Power supply current characteristics

($T_A = -40 \sim +105^\circ\text{C}$, $1.8\text{V} \leq V_{DD} \leq 5.5\text{V}$, $V_{SS} = 0\text{V}$)

item	symbol	condition		MIN.	TYP.	MAX.	unit		
current ^{note1}	I _{DD1}	Operating mode	High-speed internal oscillator	f _{HOCO} =64MHz, f _{IH} =64MHz ^{note3}		7.6	12.5	mA	
				f _{HOCO} =32MHz, f _{IH} =32MHz ^{note3}		5.8	7.8		
			High-speed main system clock	f _{MX} =20MHz ^{note2}	Input square wave		4.0	5.2	mA
					Connect the crystal		4.0	5.2	
			Subsystem clock operation	f _{SUB} =32.768kHz ^{note4}	Input square wave		70	85	uA
					Connect the crystal		70	85	
	Low-speed internal oscillator	f _{IL} =15kHz ^{note8}		70	85	uA			
	I _{DD2}	Sleep mode	High-speed internal oscillator	f _{HOCO} =64MHz, f _{IH} =64MHz ^{note3}		1.8	7.0	mA	
				f _{HOCO} =32MHz, f _{IH} =32MHz ^{note3}		1.2	3.8		
			High-speed main system clock	f _{MX} =20MHz ^{note2}	Input square wave		0.7	2.5	mA
					Connecting crystal		0.7	2.5	
			Subsystem clock operation	f _{SUB} =32.768kHz ^{c5}	Input square wave		1.2	14.5	uA
					Connecting crystal		1.2	14.5	
	Low-speed internal oscillator	f _{IL} =15kHz ^{note8}		1.4	15	uA			
I _{DD3} ^{note6}	Deep sleep mode ^{note7}	T _A =-40°C~+70°C VDD=3.0V			0.7	4.0	uA		
		T _A =-40°C~+85°C VDD=3.0V			0.7	7.0			
		T _A =-40°C~+105°C VDD=3.0V			0.7	14.5			

Note:

- 1) This is the current flowing through VDD, including the input leakage current when the input pin is fixed to VDD or VSS. TYP. Value: CPU is in the execution of multiplication instruction (IDD1),
- 2) And does not include peripheral operating current. MAX. Value: CPU is in full instruction execution action (IDD1), and includes peripheral operating current, but does not include the flow to the A/D converter,
- 3) The current of the LVD circuit, I/O port, and internal pull-up or pull-down resistors does not include the current when rewriting data flash memory.
- 4) This is the case when the high-speed internal oscillator and the subsystem clock stop oscillating.
- 5) This is the case where the high-speed main system clock and subsystem clock stop oscillating.
- 6) This is the case when the high-speed internal oscillator and the high-speed main system clock stop oscillating.
- 7) This is the case when the high-speed internal oscillator and the high-speed main system clock stop oscillating. Contains

the current flowing to the RTC, but does not include the 15-bit interval timer and watchdog

- 8) Timer current.
- 9) Does not include current to RTC, 15-bit interval timer and watchdog timer.
- 10) For the current value when the subsystem clock is running in the deep sleep mode, please refer to the current value when the subsystem clock is running in the sleep mode.
- 11) This is the case where the high-speed internal oscillator, the high-speed main system clock and the subsystem clock stop oscillating.

Note:

- 1) f_{HOCO} : The clock frequency of the high-speed internal oscillator, f_{IH} : the system clock frequency provided by the high-speed internal oscillator.
- 2) f_{SUB} : External subsystem clock frequency (XT1/XT2 clock oscillation frequency).
- 3) f_{MX} : External main system clock frequency (X1/X2 clock oscillation frequency).
- 4) f_{IL} : Clock frequency of low-speed internal oscillator.
- 5) TYP. The temperature condition of the value is $T_A=25^{\circ}\text{C}$.

(TA=-40~+105°C、1.8V≤VDD≤5.5V、VSS=0V)

parameter	symbol	condition	MIN.	TYP.	MAX.	Unit	
Low-speed internal oscillator operating current	IFIL ^{note1}			0.2		uA	
RTC operating current	IRTC ^{note1,2,3}			0.04		uA	
15-bit interval timer operating current	IIT ^{note1,2,4}			0.02		uA	
Watchdog timer operating current	IWDT ^{note1,2,5}	fIL=15kHz		0.22		uA	
A/D converter operating current	IADC ^{note1,6}	ADC HS mode@64MHz		2.2		mA	
		ADC HS mode@4MHz		1.3		mA	
		ADC LC mode@24MHz		1.1		mA	
		ADC LC mode@4MHz		0.8		mA	
PGA operating current	IPGA ^{note1,7}	Each channel		480	700	uA	
comparator operating current	ICMP ^{note1,8}	Each channel	Does not use internal reference voltage		60	100	uA
			Use internal reference voltage		80	140	uA
LVD operating current	ILVD ^{note1,9}			0.08		uA	

note:

- 1) This is the current flowing through VDD.
- 2) This is the case when the high-speed internal oscillator and the high-speed system clock stop oscillating.
- 3) This is the current that only flows to the real-time clock (RTC) (not including the operating current of the low-speed internal oscillator and XT1 oscillator circuit). When the real-time clock is running in running mode or sleep mode, the current value of the microcontroller is IDD1 or IDD2 plus the value of IRTC. In addition, when low-speed internal oscillator is selected, IFIL must be added. IDD2 when the subsystem clock is running contains the operating current of the real-time clock.
- 4) This is the current that only flows to the 15-bit interval timer (not including the operating current of the low-speed internal oscillator and XT1 oscillator circuit). When the 15-bit interval timer is running in run mode or sleep mode, the current value of the microcontroller is the value of IDD1 or IDD2 plus IIT. In addition, when low-speed internal oscillator is selected, IFIL must be added.
- 5) This is the current that only flows to the watchdog timer (including the operating current of the low-speed internal oscillator). When the watchdog timer is running, the current value of the microcontroller is IDD1 or IDD2 or IDD3 plus the value of IWDT.
- 6) This is the current that only flows to the A/D converter. When the A/D converter is running in running mode or sleep mode, the current value of the microcontroller is IDD1 or IDD2 plus the value of IADC.
- 7) This is the current that only flows to the PGA circuit. When the programmable gain amplifier circuit is running, the current value of the microcontroller is the value of IDD1 or IDD2 or IDD3 plus IPGA.
- 8) This is the current that only flows to the comparator circuit. When the comparator circuit is running, the current value of the microcontroller is the value of IDD1 or IDD2 or IDD3 plus ICMP.
- 9) This is the current that only flows to the LVD circuit. In the case of LVD circuit operation, the current value of the microcontroller is the value of IDD1 or IDD2 or IDD3 plus ILVD.

Note:

- 1) fIL : Clock frequency of low-speed internal oscillator.
- 2) TYP. The temperature condition of the value is TA=25°C.

6.6 AC characteristic

($T_A = -40 \sim +105^\circ\text{C}$, $1.8\text{V} \leq \text{VDD} \leq 5.5\text{V}$, $\text{VSS} = 0\text{V}$)

item	symbol	condition		MIN	TYP	MAX	unit
Instruction cycle (Minimum instruction execution time)	TCY	The main system clock (fMAIN) runs	$1.8\text{V} \leq \text{VDD} \leq 5.5\text{V}$	0.015625		1	μs
		Subsystem clock (fSUB) operation	$1.8\text{V} \leq \text{VDD} \leq 5.5\text{V}$	28.5	30.5	31.3	μs
External system clock frequency	fEX	$1.8\text{V} \leq \text{VDD} \leq 5.5\text{V}$		1.0		20.0	MHz
	fEXS	$1.8\text{V} \leq \text{VDD} \leq 5.5\text{V}$		32.0		35.0	kHz
High and low level width of external system clock input	tEXH, tEXL	$1.8\text{V} \leq \text{VDD} \leq 5.5\text{V}$		24			ns
	tEXHS, tEXLS	$1.8\text{V} \leq \text{VDD} \leq 5.5\text{V}$		13.7			μs
TI00 ~ TI03, TI10 ~ TI13, input high and low level width	tTIH, tTIL	$1.8\text{V} \leq \text{VDD} \leq 5.5\text{V}$		$1/\text{fMCK} + 10$			ns
TO00 ~ TO03, TO10 ~ TO13, output frequency	fTO	$4.0\text{V} \leq \text{VDD} \leq 5.5\text{V}$				16	MHz
		$2.4\text{V} \leq \text{VDD} < 4.0\text{V}$				8	MHz
		$1.8\text{V} \leq \text{VDD} < 2.4\text{V}$				4	MHz
CLKBUZ0, CLKBUZ1 Output frequency	fPCL	$4.0\text{V} \leq \text{VDD} \leq 5.5\text{V}$				16	MHz
		$2.4\text{V} \leq \text{VDD} < 4.0\text{V}$				8	MHz
		$1.8\text{V} \leq \text{VDD} < 2.4\text{V}$				4	MHz
Interrupt input high and low level width	tINTH, tINTL	INTP0 ~ INTP3	$1.8\text{V} \leq \text{VDD} \leq 5.5\text{V}$	1			μs
Key interrupt input high and low level width	tKR	KR0 ~ KR5	$1.8\text{V} \leq \text{VDD} \leq 5.5\text{V}$	250			ns
RESETB low-level width	tRSL			10			μs

Note: fMCK: Operating clock frequency of timer4 unit.

6.7 Peripheral features

6.7.1 Universal interface unit

1) UART mode

- ($T_A = -40 \sim +85^\circ\text{C}$, $1.8\text{V} \leq \text{VDD} \leq 5.5\text{V}$, $\text{Vss} = 0\text{V}$)

item	condition		Specification Value		unit
			MIN	MAX	
Transfer rate	$1.8\text{V} \leq \text{VDD} \leq 5.5\text{V}$			fMCK/6	bps
		The theoretical value of the maximum transfer rate fMCK=fCLK		10.6	Mbps

- ($T_A = +85 \sim +105^\circ\text{C}$, $1.8\text{V} \leq \text{VDD} \leq 5.5\text{V}$, $\text{Vss} = 0\text{V}$)

item	condition		Specification Value		unit
			MIN	MAX	
Transfer rate	$1.8\text{V} \leq \text{VDD} \leq 5.5\text{V}$			fMCK/12	bps
		Theoretical value of the maximum transfer rate fMCK=fCLK		5.3	Mbps

2) Three-wire SPI mode (master mode, internal clock output)

- ($T_A = -40 \sim +105^\circ\text{C}$, $1.8\text{V} \leq \text{VDD} \leq 5.5\text{V}$, $\text{Vss} = 0\text{V}$)

item	symbol	condition	$-40 \sim +85^\circ\text{C}$		$+85 \sim +105^\circ\text{C}$		unit
			MIN	MAX	MIN	MAX	
SCLKp cycle time	tKCY1	tKCY1 \geq 2/fCLK	$4.0\text{V} \leq \text{VDD} \leq 5.5\text{V}$	31.25		62.5	ns
			$2.7\text{V} \leq \text{VDD} \leq 5.5\text{V}$	41.67		83.33	
			$2.4\text{V} \leq \text{VDD} \leq 5.5\text{V}$	65		125	ns
			$1.8\text{V} \leq \text{VDD} \leq 5.5\text{V}$	125		250	ns
SCLKp high/low level width	tKH1, tKL1	$4.0\text{V} \leq \text{VDD} \leq 5.5\text{V}$	tKCY1/2-4		tKCY1/2-7	ns	
		$2.7\text{V} \leq \text{VDD} \leq 5.5\text{V}$	tKCY1/2-5		tKCY1/2-10	ns	
		$2.4\text{V} \leq \text{VDD} \leq 5.5\text{V}$	tKCY1/2-10		tKCY1/2-20	ns	
		$1.8\text{V} \leq \text{VDD} \leq 5.5\text{V}$	tKCY1/2-19		tKCY1/2-38	ns	
SDIp preparation time (to SCLKp \uparrow)	tSIK1	$4.0\text{V} \leq \text{VDD} \leq 5.5\text{V}$	12		23	ns	
		$2.7\text{V} \leq \text{VDD} \leq 5.5\text{V}$	17		33	ns	
		$2.4\text{V} \leq \text{VDD} \leq 5.5\text{V}$	20		38	ns	
		$1.8\text{V} \leq \text{VDD} \leq 5.5\text{V}$	28		55	ns	
SDIp hold time (to SCLKp \uparrow)	tKS11	$1.8\text{V} \leq \text{VDD} \leq 5.5\text{V}$	5		10	ns	
SCLKp \downarrow →SDOp output delay time	tKSO1	$1.8\text{V} \leq \text{VDD} \leq 5.5\text{V}$ C=20pF ^{note1}		5		10	ns

note1.: C is the load capacitance of the SCLKp and SDOp output lines.

note: Through the port inputmode register and the port outputmode register, the SDIp pin is selected as the normal input buffer and theSDOp the pin and SCLKp pin are selected as the usual output mode.

3) Three-wire SPI mode (slave mode, external clock input)

($T_A = -40 \sim +105^\circ\text{C}$, $1.8\text{V} \leq \text{VDD} \leq 5.5\text{V}$, $\text{Vss} = 0\text{V}$)

item	symbol	condition		-40 ~ +85°C		+85 ~ +105°C		unit
				MIN	MAX	MIN	MAX	
SCLKp cycle time	tKCY2	$4.0\text{V} \leq \text{VDD} \leq 5.5\text{V}$	$20\text{MHz} < \text{fMCK}$	8/fMCK		16/fMCK		ns
			$\text{fMCK} \leq 20\text{MHz}$	6/fMCK		12/fMCK		ns
		$2.7\text{V} \leq \text{VDD} \leq 5.5\text{V}$	$16\text{MHz} < \text{fMCK}$	8/fMCK		16/fMCK		ns
			$\text{fMCK} \leq 16\text{MHz}$	6/fMCK		12/fMCK		ns
		$2.4\text{V} \leq \text{VDD} \leq 5.5\text{V}$		6/fMCK and 500		12/fMCK and 1000		ns
$1.8\text{V} \leq \text{VDD} \leq 5.5\text{V}$		6/fMCK and 750		12/fMCK and 1500		ns		
SCLKp high/low level width	tKH2, tKL2	$4.0\text{V} \leq \text{VDD} \leq 5.5\text{V}$		tKCY1/2-7		tKCY1/2-14		ns
		$2.7\text{V} \leq \text{VDD} \leq 5.5\text{V}$		tKCY1/2-8		tKCY1/2-16		ns
		$1.8\text{V} \leq \text{VDD} \leq 5.5\text{V}$		tKCY1/2-18		tKCY1/2-36		ns
SDIp preparation time (To SCLKp↑)	tSIK2	$2.7\text{V} \leq \text{VDD} \leq 5.5\text{V}$		1/fMCK+20		1/fMCK+40		ns
		$1.8\text{V} \leq \text{VDD} \leq 5.5\text{V}$		1/fMCK+30		1/fMCK+60		ns
SDIp hold time (To SCLKp↑)	tKSI2	$1.8\text{V} \leq \text{VDD} \leq 5.5\text{V}$		1/fMCK+31		1/fMCK+62		ns
SCLKp↓→SDOp output delay time	tKSO2	$2.7\text{V} \leq \text{VDD} \leq 5.5\text{V}$ C=30pF ^{note1}			2/fMCK+44		2/fMCK+66	ns
		$2.4\text{V} \leq \text{VDD} \leq 5.5\text{V}$ C=30pF ^{note1}			2/fMCK+75		2/fMCK+113	ns
		$1.8\text{V} \leq \text{VDD} \leq 5.5\text{V}$ C=30pF ^{note1}			2/fMCK+100		2/fMCK+150	ns

note1: C is the load capacitance of the SCLKp and SDOp output lines.

note: Through the port inputmode register and the port outputmode register, select the SDIp pin and SCLKp pin as the normal input buffer and select the SDOp pin as the normal output mode.

4) Four-wire SPI mode (slave mode, external clock input)

($T_A = -40 \sim +105^\circ\text{C}$, $1.8\text{V} \leq \text{VDD} \leq 5.5\text{V}$, $\text{Vss} = 0\text{V}$)

item	symbol	condition		-40 ~ +85°C		+85 ~ +105°C		unit
				MIN	MAX	MIN	MAX	
SSI00 set up time	tSSIK	DAPmn=0	$2.7\text{V} \leq \text{VDD} \leq 5.5\text{V}$	120		240		ns
			$1.8\text{V} \leq \text{VDD} \leq 5.5\text{V}$	200		400		ns
		DAPmn=1	$2.7\text{V} \leq \text{VDD} \leq 5.5\text{V}$	1/fMCK+120		1/fMCK+240		ns
			$1.8\text{V} \leq \text{VDD} \leq 5.5\text{V}$	1/fMCK+200		1/fMCK+400		ns
SSI00 hold time	tKSSI	DAPmn=0	$2.7\text{V} \leq \text{VDD} \leq 5.5\text{V}$	1/fMCK+120		1/fMCK+240		ns

			$1.8V \leq VDD \leq 5.5V$	$1/fMCK+200$		$1/fMCK+400$		ns
		DAPmn=1	$2.7V \leq VDD \leq 5.5V$	120		240		ns
			$1.8V \leq VDD \leq 5.5V$	200		400		ns

note: Through the port inputmode register and the port outputmode register, select the SDIp pin and SCLKp pin as the normal input buffer and select the SDOp pin as the normal outputmode.

5) Simple IIC mode

($T_A = -40 \sim +105^\circ C$ 、 $1.8V \leq VDD \leq 5.5V$ 、 $V_{SS} = 0V$)

item	symbol	condition	-40 ~ +85°C		+85 ~ +105°C		unit
			MIN	MAX	MIN	MAX	
SCLr Clock frequency	fSCL	$2.7V \leq VDD \leq 5.5V$ Cb = 50 pF, Rb = 2.7 kΩ		1000 ^{note1}		400 ^{note1}	kHz
		$1.8V \leq VDD \leq 5.5V$ Cb = 100 pF, Rb = 3 kΩ		400 ^{note1}		100 ^{note1}	
		$1.8V \leq VDD \leq 2.7V$ Cb = 100 pF, Rb = 5 kΩ		300 ^{note1}		75 ^{note1}	
Hold time when SCLr is low	tLOW	$2.7V \leq VDD \leq 5.5V$ Cb = 50 pF, Rb = 2.7 kΩ	475		1200		ns
		$1.8V \leq VDD \leq 5.5V$ Cb = 100 pF, Rb = 3 kΩ	1150		4600		
		$1.8V \leq VDD \leq 2.7V$ Cb = 100 pF, Rb = 5 kΩ	1550		6500		
Hold time when SCLr is high	tHIGH	$2.7V \leq VDD \leq 5.5V$ Cb = 50 pF, Rb = 2.7 kΩ	475		1200		ns
		$1.8V \leq VDD \leq 5.5V$ Cb = 100 pF, Rb = 3 kΩ	1150		4600		
		$1.8V \leq VDD \leq 2.7V$ Cb = 100 pF, Rb = 5 kΩ	1550		6500		
Data establishment time (received)	tSU: DAT	$2.7V \leq VDD \leq 5.5V$ Cb = 50 pF, Rb = 2.7 kΩ		$1/fMCK+85$ ^{note2}		$1/fMCK+220$ ^{note2}	ns
		$1.8V \leq VDD \leq 5.5V$ Cb = 100 pF, Rb = 3 kΩ		$1/fMCK+145$ ^{note2}		$1/fMCK+580$ ^{note2}	
		$1.8V \leq VDD \leq 2.7V$ Cb = 100 pF, Rb = 5 kΩ		$1/fMCK+230$ ^{note2}		$1/fMCK+1200$ ^{note2}	
Data retention time (send)	tHD: DAT	$2.7V \leq VDD \leq 5.5V$ Cb = 50 pF, Rb = 2.7 kΩ		305		770	ns
		$1.8V \leq VDD \leq 5.5V$ Cb = 100 pF, Rb = 3 kΩ		355		1420	
		$1.8V \leq VDD \leq 2.7V$ Cb = 100 pF, Rb = 5 kΩ		405		2070	

note: 1. Must be set to at least fMCK/4.

2. The set value of fMCK cannot exceed the holding time of SCLr="L" and SCLr="H".

6.7.2 Serial interface IICA

1) I2C standard mode

($T_A = -40 \sim +105^\circ\text{C}$, $1.8\text{V} \leq V_{DD} \leq 5.5\text{V}$, $V_{SS} = 0\text{V}$)

item	symbol	condition	Specification Value		unit
			MIN	MAX	
SCLA0 clock frequency	fSCL	Standard mode: fCLK \geq 1MHz		100	kHz
Start condition set up time	tSU: STA		4.7		μs
Start condition hold time note1	tHD: STA		4.0		μs
Hold time when SCLA0 is low	tLOW		4.7		μs
Hold time when SCLA0 is high	tHIGH		4.0		μs
Data establishment time (received)	tSU: DAT		250		ns
Data retention time (send) ^{note2}	tHD: DAT		0	3.45	μs
Stop condition set up time	tSU: STO		4.0		μs
Bus idle time	tBUF		4.7		μs

note:

- Generate the first clock pulse after generating the start condition or restarting the condition.
- During normal transmission, tHD: the maximum value of DAT (MAX.) needs to be guaranteed, and it is necessary to wait for an acknowledgement (ACK).

Note:

The MAX. value of Cb (communication line capacitance) of each mode and the value of Rb (communication line pull-up resistance value) at this time are as follows:

Standard mode: Cb=400pF, Rb=2.7k Ω

2) I2C fast mode

($T_A = -40 \sim +105^\circ\text{C}$, $1.8\text{V} \leq V_{DD} \leq 5.5\text{V}$, $V_{SS} = 0\text{V}$)

item	symbol	condition	Specification Value		unit
			MIN	MAX	
SCLA0 clock frequency	fSCL	Fast mode: fCLK \geq 3.5MHz		400	kHz
Start condition set up time	tSU: STA		0.6		μs
Start condition hold time note1	tHD: STA		0.6		μs
Hold when SCLA0 is low time	tLOW		1.3		μs

Hold when SCLA0 is high time	tHIGH		0.6		μs
Data set up time (received)	tSU: DAT		100		ns
Data hold time (send) ^{note2}	tHD: DAT		0	0.9	μs
Stop condition set up time	tSU: STO		0.6		μs
Bus idle time	tBUF		1.3		μs

note:

- a) Generate the first clock pulse after generating the start condition or restarting the condition.
- b) During normal transmission, tHD: the maximum value of DAT (MAX.) needs to be guaranteed, and it is necessary to wait for an acknowledgement (ACK).

Note: The MAX. value of Cb (communication line capacitance) of each mode and the value of Rb (communication line pull-up resistance value) at this time are as follows:

Fast mode: Cb=320pF, Rb=1.1kΩ

3) I2C enhanced fast mode

(TA=-40~+105°C、1.8V≤VDD≤5.5V、VSS=0V)

item	symbol	condition	Specification Value		unit
			MIN	MAX	
SCLA0 clock frequency	fSCL	Enhanced fast mode: fCLK≥10MHz		1000	kHz
Start condition set up time	tSU: STA		0.26		μs
Start condition hold time <small>note1</small>	tHD: STA		0.26		μs
Hold time when SCLA0 is low	tLOW		0.5		μs
When SCLA0 is high hold time	tHIGH		0.26		μs
Data set up time (received)	tSU: DAT		50		ns
Data hold time (send) ^{note2}	tHD: DAT		0	0.45	μs
Stop condition set up time	tSU: STO		0.26		μs
Bus idle time	tBUF		0.5		μs

note:

- a) Generate the first clock pulse after generating the start condition or restarting the condition.
- b) During normal transmission, tHD: the maximum value of DAT (MAX.) needs to be guaranteed, and it is necessary to wait for an acknowledgement (ACK).

Note: The MAX. value of Cb (communication line capacitance) of each mode and the value of Rb (communication line pull-up resistance value) at this time are as follows:

Enhanced fast mode: Cb=120pF, Rb=1.1KΩ

6.7.3 USB unit characteristics

1) USB characteristic

(VCC = VCC_USB = 3.0 to 3.6 V, Ta = -20 to +85°C (USBCLKSEL = 1),

Ta = -40 to +105°C (USBCLKSEL = 0))

item		symbol	Specification Value		unit	condition	
			MIN	MAX			
Input characteristic	inputhigh level	VIH	2.0	-	V	-	
	inputlow level	VIL	-	0.8	V	-	
	Differential input sensitivity	VDI	0.2	-	V	DP - DM	
	Differential common mode range	VCM	0.8	2.5	V	-	
Output characteristic	outputhigh level	VOH	2.8	VCC_USB	V		
	outputlow level	VOL	0.0	0.3	V		
	Crossover voltage		VCRS			V	
	Rise Time	FS	tr			ns	
		LS					
	Fall time	FS	tf			ns	
		LS					
	Rise and fall time ratio	FS	tr/tf			%	
		LS					
	output resistance		ZDRV			Ω	
VBUS	VBUS input voltage	VIH	VCC x 0.8	-	V		
		VIL	-	VCC x 0.2	V		
Pull up pull down	Pull-up resistor	RPD			Ω		
	Pull-down resistor	RPUI			Ω		
		RPUA			Ω		
Charging batteries specification	D+ leakage current	IDP_SINK			μA		
	D-Leakage current	IDM_SINK			μA		

	DCD source current	IDP_SRC			μA	
	Data detection voltage	VDAT_REF	0.25	0.4	V	
	D+ source voltage	VDP_SRC	0.5	0.7	V	
	D-source voltage	VDM_SRC	0.5	0.7	V	

2) USB external power supply

item	Specification Value			unit	condition
	MIN	TYP	MAX		
UVDD supply current	-		50	mA	
UVDD supply voltage	3.0	-	3.6	V	

6.8 Analog characteristic

6.8.1 A/D converter characteristic

The distinction of A/D converter characteristic

Input channel	Reference voltage	Reference voltage (+)=AVREFP Reference voltage (-)=AVREFM	Reference voltage (+)=VDD Reference voltage (-)=VSS
ANI0~ANI36			
Internal reference voltage, output voltage of temperature sensor		See 6.7.1(1).	See (2).

1) Select the case of reference voltage (+)=AVREFP/ANI0, reference voltage (-)=AVREFM/ANI1

($T_A = -40 \sim +105^\circ\text{C}$, $1.8\text{V} \leq \text{AVREFP} \leq \text{VDD} \leq 5.5\text{V}$, $\text{VSS} = 0\text{V}$, reference voltage (+)=AVREFP, reference voltage (-)=AVREFM=0V)

item	symbol	condition		MIN.	TYP.	MAX.	unit
Resolution	RES				12		bit
Composite error note 1	AINL	12-bit resolution	$1.8\text{V} \leq \text{AVREFP} \leq 5.5\text{V}$		3		LSB
Conversion time note 3	t_{CONV}	12-bit resolution Conversion target: ANI2~ANI15	$1.8\text{V} \leq \text{VDD} \leq 5.5\text{V}$	45			Tmclk
		12-bit resolution Conversion object: internal reference voltage, temperature sensor output voltage, PGA output voltage	$1.8\text{V} \leq \text{VDD} \leq 5.5\text{V}$	72			Tmclk
Zero error note 1	EZS	12-bit resolution	$1.8\text{V} \leq \text{AVREFP} \leq 5.5\text{V}$		0		LSB
Full scale error note 1	EFS	12-bit resolution	$1.8\text{V} \leq \text{AVREFP} \leq 5.5\text{V}$		0		LSB
Integral linearity error note 1	ILE	12-bit resolution	$1.8\text{V} \leq \text{AVREFP} \leq 5.5\text{V}$			± 1	LSB
Differential linearity error note 1	DLE	12-bit resolution	$1.8\text{V} \leq \text{AVREFP} \leq 5.5\text{V}$			± 1.5	LSB
Analog input voltage	V_{AIN}	ANI2~ANI36		0		AVREFP	V
		Internal reference voltage ($1.8\text{V} \leq \text{VDD} \leq 5.5\text{V}$)				V_{BGR} note2	V
		The output voltage of the temperature sensor ($1.8\text{V} \leq \text{VDD} \leq 5.5\text{V}$)				V_{TMPS25} note2	V

note: 1. Does not include quantization error ($\pm 1/2$ LSB).

2. Please refer to "6.8.2 Characteristic of Temperature Sensor/Internal Reference Voltage".

3. Tmclk is the AD action clock cycle, the maximum action frequency is 64MHz.

2) Select the case of reference voltage (+)=VDD and reference voltage (-)=VSS

(TA=-40~+105°C, 1.8V≤VDD≤5.5V, VSS=0V, reference voltage (+)=VDD, reference voltage (-)=VSS)

item	symbol	condition		MIN.	TYP.	MAX.	unit
Resolution	RES				12		bit
Composite error note 1	AINL	12-bit resolution	$1.8V \leq AV_{REFP} \leq 5.5V$		6		LSB
Conversion time note 3	tCONV	12-bit resolution Conversion target: ANI0~ANI36	$1.8V \leq VDD \leq 5.5V$	45			Tmclk
		12-bit resolution Conversion object: internal reference voltage, temperature sensor output voltage, PGA output voltage	$1.8V \leq VDD \leq 5.5V$	72			Tmclk
Zero error note 1	EZS	12-bit resolution	$1.8V \leq AV_{REFP} \leq 5.5V$		0		LSB
Full scale error note 1	EFS	12-bit resolution	$1.8V \leq AV_{REFP} \leq 5.5V$		0		LSB
Integral linearity error note 1	ILE	12-bit resolution	$1.8V \leq AV_{REFP} \leq 5.5V$			±2	LSB
Differential linearity error note 1	DLE	12-bit resolution	$1.8V \leq AV_{REFP} \leq 5.5V$			±3	LSB
Analog input voltage	VAIN	ANI0~ANI36		0		VDD	V
		Internal reference voltage (1.8V≤VDD≤5.5V)		VBGR note2			V
		The output voltage of the temperature sensor (1.8V≤VDD≤5.5V)		VTMPS25 note2			V

note: 1. Does not include quantization error (±1/2 LSB).

2. Please refer to "6.8.2 Characteristic of Temperature Sensor/Internal Reference Voltage".

3. Tmclk is the AD action clock cycle, the maximum action frequency is 64MHz.

6.8.2 Characteristic of temperature sensor/internal reference voltage

($T_A = -40 \sim +105^\circ\text{C}$, $1.8\text{V} \leq \text{VDD} \leq 5.5\text{V}$, $\text{VSS} = 0\text{V}$)

item	symbol	condition	MIN	TYP	MAX	unit
The output voltage of the temperature sensor	VTMPS25	ADS register=80H, $T_A = +25^\circ\text{C}$		1.09		V
Internal reference voltage	VBGR	ADS register=81H	1.38 ^{note1}	1.45	1.5 ^{note1}	V
Temperature Coefficient	FVTMPS			-3.5		mV/ $^\circ\text{C}$
Stable operation waiting time	tAMP		5			μs

note1: Low temperature Specification Value is guaranteed by design, mass production does not measure low temperature conditions.

6.8.3 comparator

($T_A = -40 \sim +105^\circ\text{C}$, $1.8\text{V} \leq \text{VDD} \leq 5.5\text{V}$, $\text{VSS} = 0\text{V}$)

item	symbol	condition	MIN	TYP	MAX	unit
input deviation voltage	V_{IOCMP}			± 10	± 40	mV
input voltage range	Ivcmp		0		VDD	V
Internal reference voltage deviation	ΔV_{IREF}	CmRVM register: 7FH ~ 80H (m = 0, 1)			± 2	LSB
		others			± 1	LSB
Response time	tCR, tCF	input amplitude $\pm 100\text{mV}$		70	150	ns
Stable operation time ^{note1}	tCMP	CMPn=0->1	VDD= 3.3 ~ 5.5V		1	μs
			VDD= 1.8 ~ 3.3V		3	
Reference voltage stabilization time	tVR	CVRE=0->1 ^{note2}			20	μs
operating current	I _{CMPDD}	Separately, it is defined as the operation current of peripheral functions.				

note1: The time required from the enable of the comparator action (CMPnEN=0 → 1) to meeting the various DC/AC style requirements of CMP.

note2: After the internal reference voltage generator is enabled (by setting the CVREm bit to 1; m = 0 to 1), the comparator output can be enabled after the reference voltage stabilization time (CnOE bit = 1; n = 0 to 1)

6.8.4 PGA electrical characteristic

TA=25°C, VDD=5V, VIN+=0.01V, unless otherwise specified. (G is the gain multiple)

symbol	parameter	condition	Min value	Typical value	Max value	unit
VDD	voltage	-	2.5	-	5.5	V
I _Q	Quiescent Current	V _{OUT} =2V	-	0.5	0.7	mA
I _{SD}	Shutdown current	-	-	10	-	nA
T _A	Operating temperature	-	-40	25	105	°C
inputcharacteristic						
V _{OS}	Input offset voltage	Not zero offset (PGAADJ=20H)	-	±2.5	-	mV
		Zero offset	-	±0.1	±0.2	
V _{CM}	Common mode input voltage range	G=1	0.032	-	(VDD-1.5)/G	V
		G=2	0.016			
		G=4	0.008			
		G=8	0.004			
		G=16	0.002			
		G=32, 64, 128	0.001			
I _B	input bias current	-	-	10	-	pA
I _{OS}	Input offset current	-	-	10	-	pA
Output characteristic						
EG	Gain error	G=1, 2, 4, 8, 16	-1	-	1	%
		G=32	-2	-	2	
		G=64, 128	-4	-	4	
C _{LOAD}	Capacitive load	-	-	10	-	pF
V _{OH}	Maximum output voltage	-40°C~105°C	-	-	VDD-1.5	V
V _{OL}	Minimum output voltage	-40°C~105°C	0.032	-	-	V
Frequency characteristic						
BW	bandwidth	C _{LOAD} =10pF, G=1	-	1.5	-	MHz
PSRR	Power supply rejection ratio	VDD=2.5~5.5V, G=16	-	75	-	dB
CMRR	Common mode rejection ratio	-40°C~105°C	-	80	-	dB
Transient characteristic						
SR	Slew rate	C _{LOAD} =10pF, G=32	-	10	-	V/μs
T _{STB}	stable time	-	-	-	2	μs
T _{SH(1)}	Sampling hold time	-	-	3	-	μs

6.8.5 POR circuit characteristic

($T_A = -40 \sim +105^\circ\text{C}$, $V_{SS} = 0\text{V}$)

item	symbol	condition	MIN	TYP	MAX	unit
Detection voltage	VPOR	When the power supply voltage rises		1.60	1.75	V
	VPDR	When the power supply voltage drops	1.37	1.50	1.55	V
Minimum pulse width ^{note1}	TPW		300			μs

note1.: This is the time required for POR to reset when VDD is lower than VPDR. In addition, in the deep sleep mode, when the main system clock (fMAIN) is stopped by setting bit0 (HIOSTOP) and bit7 (MSTOP) of the clock operation status control register (CSC), the oscillation of the main system clock (fMAIN) is stopped from VDD lower than 0.7V to rise above VPOR. Time required for POR reset.

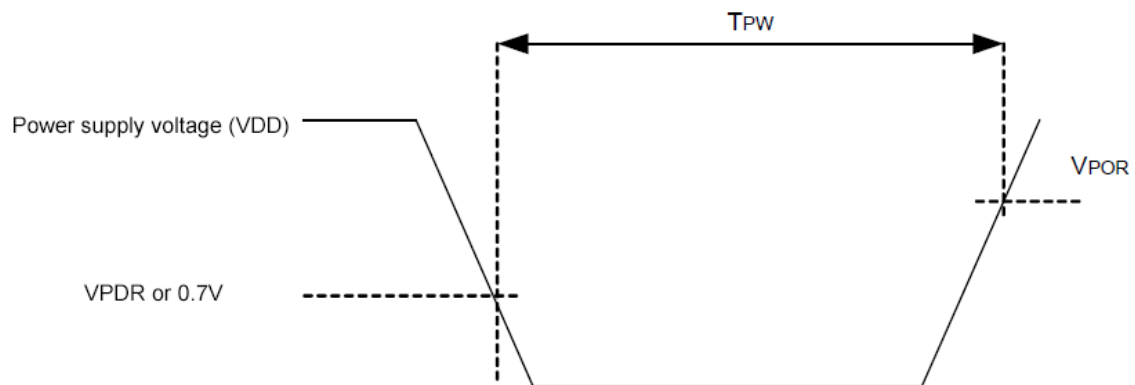

6.8.6 LLVD circuit characteristic

1) Reset mode and interrupt mode

($T_A = -40 \sim +105^\circ\text{C}$, $V_{PDR} \leq V_{DD} \leq 5.5\text{V}$, $V_{SS} = 0\text{V}$)

item	symbol	condition	MIN	TYP	MAX	unit
Detection voltage	VLVD0	power supply voltage rises		4.06		V
		power supply voltage drops		3.98		V
	VLVD1	power supply voltage rises		3.75		V
		power supply voltage drops		3.67		V
	VLVD2	power supply voltage rises		3.13		V
		power supply voltage drops		3.06		V
	VLVD3	power supply voltage rises		3.02		V
		power supply voltage drops		2.96		V
	VLVD4	power supply voltage rises		2.92		V
		power supply voltage drops		2.86		V
	VLVD5	power supply voltage rises		2.81		V
		power supply voltage drops		2.75		V
	VLVD6	power supply voltage rises		2.71		V
		power supply voltage drops		2.65		V
	VLVD7	power supply voltage rises		2.61		V
		power supply voltage drops		2.55		V
	VLVD8	power supply voltage rises		2.50		V
		power supply voltage drops		2.45		V
	VLVD9	power supply voltage rises		2.09		V
		power supply voltage drops		2.04		V
	VLVD10	power supply voltage rises		1.98		V
		power supply voltage drops		1.94		V
VLVD11	power supply voltage rises		1.88		V	
	power supply voltage drops		1.84		V	
Minimum pulse width	t _{LW}		300			μs
Detection delay					300	μs

2) Interrupt and reset mode

(TA=-40~+105°C, VPDR ≤VDD≤5.5V, VSS=0V)

item	symbol	condition	MIN.	TYP.	MAX.	unit
Interrupt & reset mode	VLVDA0	VPOC2、VPOC1、VPOC0=0、0、0, Decrease reset voltage		1.63		V
	VLVDA1	LVIS1、LVIS0=1、0	rising reset release voltage	1.77		V
			drop interrupt voltage	1.73		V
	VLVDA2	LVIS1、LVIS0=0、1	rising reset release voltage	1.88		V
			drop interrupt voltage	1.84		V
	VLVDA3	LVIS1、LVIS0=0、0	rising reset release voltage	2.92		V
			drop interrupt voltage	2.86		V
	VLVDB0	VPOC2、VPOC1、VPOC0=0、0、1, decrease reset voltage		1.84		V
	VLVDB1	LVIS1、LVIS0=1、0	rising reset release voltage	1.98		V
			drop interrupt voltage	1.94		V
	VLVDB2	LVIS1、LVIS0=0、1	rising reset release voltage	2.09		V
			drop interrupt voltage	2.04		V
	VLVDB3	LVIS1、LVIS0=0、0	rising reset release voltage	3.13		V
			drop interrupt voltage	3.06		V
	VLVDC0	VPOC2、VPOC1、VPOC0=0、1、0, decrease reset voltage		2.45		V
	VLVDC1	LVIS1、LVIS0=1、0	rising reset release voltage	2.61		V
			drop interrupt voltage	2.55		V
	VLVDC2	LVIS1、LVIS0=0、1	rising reset release voltage	2.71		V
			drop interrupt voltage	2.65		V
	VLVDC3	LVIS1、LVIS0=0、0	rising reset release voltage	3.75		V
			drop interrupt voltage	3.67		V
	VLVDD0	VPOC2、VPOC1、VPOC0=0、1、1, decrease reset voltage		2.75		V
	VLVDD1	LVIS1、LVIS0=1、0	rising reset release voltage	2.92		V
			drop interrupt voltage	2.86		V
VLVDD2	LVIS1、LVIS0=0、1	rising reset release voltage	3.02		V	
		drop interrupt voltage	2.96		V	
VLVDD3	LVIS1、LVIS0=0、0	rising reset release voltage	4.06		V	
		drop interrupt voltage	3.98		V	

6.8.7 The rising slope of the power supply voltage characteristic

($T_A = -40 \sim +105^\circ\text{C}$, $V_{SS} = 0\text{V}$)

item	symbol	condition	MIN	TYP	MAX	unit
The rising slope of the power supply voltage	SVDD				54	V/ms

7 Package size chart

7.1 48 pin product

48LQFP (7x7mm, 0.5mm spacing)

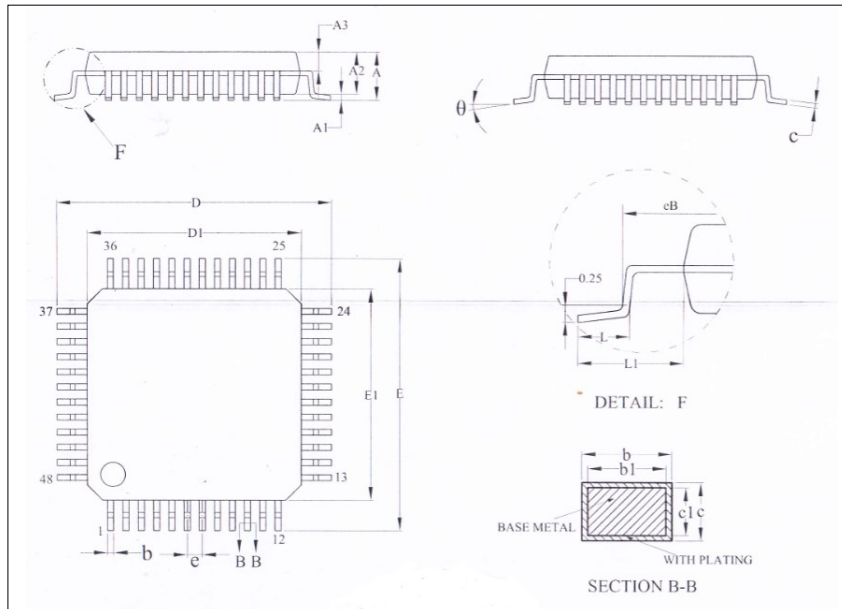

Symbol	Millimeter		
	Min	Nom	Max
A	-	-	1.60
A1	0.05	-	0.15
A2	1.35	1.40	1.45
A3	0.59	0.64	0.69
b	0.18	-	0.26
b1	0.17	0.20	0.23
c	0.13	-	0.17
c1	0.12	0.13	0.14
D	8.80	9.00	9.20
D1	6.90	7.00	7.10
E	8.80	9.00	9.20
E1	6.90	7.00	7.10
eB	8.10	-	8.25
e	0.50BSC		
L	0.45	-	0.75
L1	1.00REF		
θ	0	-	7°

7.2 64 pin product

64LQFP (7x7mm, 0.4mm spacing)

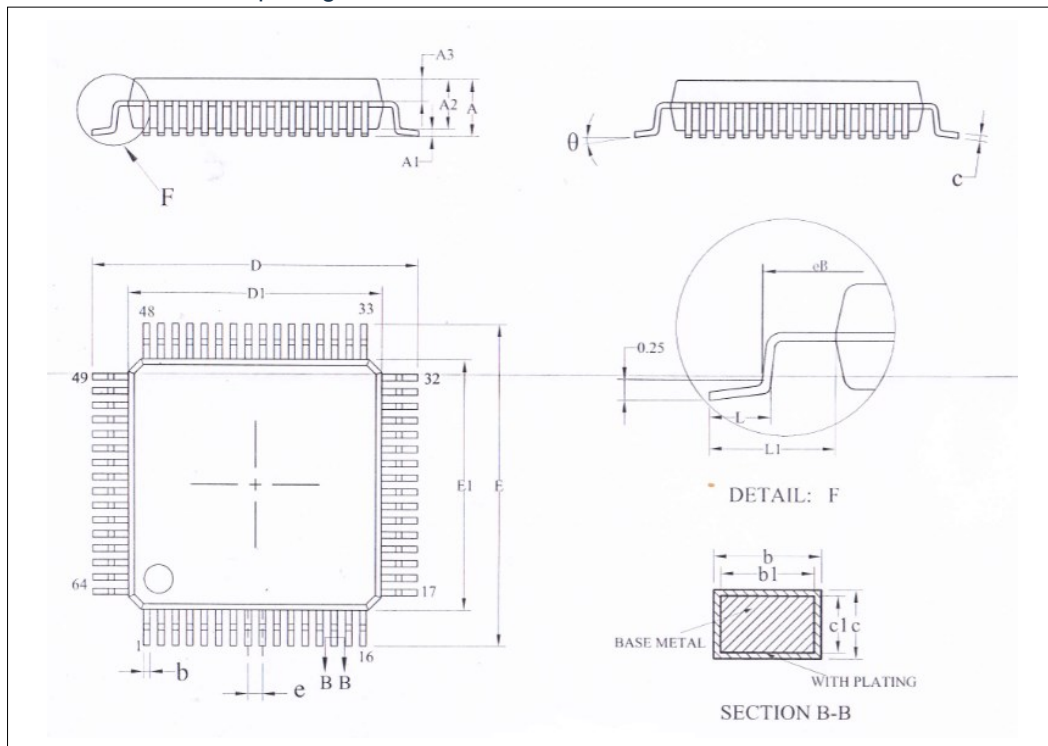

Symbol	Millimeter		
	Min	Nom	Max
A	-	-	1.60
A1	0.05	-	0.15
A2	1.35	1.40	1.45
A3	0.59	0.64	0.69
b	0.16	-	0.24
b1	0.15	0.18	0.21
c	0.13	-	0.17
c1	0.12	0.13	0.14
D	8.80	9.00	9.20
D1	6.90	7.00	7.10
E	8.80	9.00	9.20
E1	6.90	7.00	7.10
eB	8.10	-	8.25
e	0.40BSC		
L	0.45	-	0.75
L1	1.00REF		
θ	0	-	7°

8 Modify resume

Rev.	Release date	Content modified	
		Page/section	content
1.0	2020/11/4	-	Original Issue
1.1	2020/11/10	-	Update PGA characteristic
1.2	2020/12/16	-	Update pin diagram
1.3	2021/01/19		Update format
1.4	2021/02/01	6.5.2	Update Mistakes
1.5	2021/04/14	6.4.2, 6.8.2	Add low temperature condition note explanation
1.6	2021/06/10	4.1, 4.2	Modify the pin function description
		-	Correct the misrepresentation of SSIE
1.7	2021/06/22	4.1	Update Mistakes
1.8	2021/12/14	2, 6.5	Update Mistakes